

Investigation of neutrino properties with
the low-background germanium spectrometer GEMMA-III

GEMMA-III

CODE OF THEME 03-2-1100-2010/2018

V.V.Belov, V.B.Brudanin, V.G.Egorov, M.V.Fomina, A.V.Lubashevskiy, D.V.Medvedev,
D.V.Ponomarev, V.G.Sandukovsky M.V.Shirchenko, S.V.Rozov, I.E.Rozova, I.V.Zhitnikov,
E.A.Yakushev, D.R.Zinatulina

Laboratory of Nuclear Problems, JINR

NAMES OF PROJECT LEADERS: V.B.Brudanin

NAME OF PROJECT DEPUTY LEADERS: A.V.Lubashevskiy, E.A.Yakushev

DATE OF SUBMISSION OF PROPOSAL OF PROJECT TO SOD _____

DATE OF THE LABORATORY STC _____ DOCUMENT NUMBER _____

STARTING DATE OF PROJECT January 2019 (FOR EXTENSION OF
PROJECT — DATE OF ITS FIRST APPROVAL) 07.02.2014

PROJECT ENDORSEMENT LIST

Investigation of neutrino properties with
the low-background germanium spectrometer GEMMA-III

GEMMA-III

CODE OF THEME 03-2-1100-2010/2018

NAME OF PROJECT LEADER: Viktor Brudanin

APPROVED BY JINR DIRECTOR

ENDORSED BY

SIGNATURE

DATE

JINR VICE-DIRECTOR

CHIEF SCIENTIFIC SECRETARY

CHIEF ENGINEER

HEAD OF SCIENCE ORGANIZATION DEPARTMENT

LABORATORY DIRECTOR

LABORATORY CHIEF ENGINEER

PROJECT LEADER

PROJECT DEPUTY LEADERS

ENDORSED

RESPECTIVE PAC

Schedule proposal and resources required for the implementation of the Project

GEMMA-III

List of parts and devices; Resources; Financial sources		Cost of parts (K US\$), resources needs	Allocation of resources and money			
			1 st year	2 nd year	3 rd year	
Main parts and equipment	1. Cryogenic equipment for the detectors.	70	70			
	2. Materials and equipment for calibration and shielding.	40	25	10	5	
	3. Electronics NIM	50	40	10		
	4. Electronics VME	55	35	20		
	Total	215	170	40	5	
Resources	Norm-hours	DLNP workshop	600	200	200	200
Financial sources	JINR budget	Budget spending	215	170	40	5
	Off-budget sources	Grants; Other sources (these funds are not currently guaranteed)	45	20	15	10

PROJECT LEADER

V.Brudanin

Estimated expenditures for the Project GEMMA-III, Investigations of neutrino properties with the low-background germanium spectrometer GEMMA-III

#	Designation for outlays	Total cost	1 year	2 year	3 year
Direct expenses for the project					
1.	Networking	6.0K US\$	2.0	2.0	2.0
2.	DLNP workshop	600 norm-hours	200	200	200
3.	Materials	40.0K US\$	25.0	10.0	5.0
4.	Equipment	175.0K US\$	145.0	30.0	0.0
5.	Expenses for R&D on a contract base	6.0K US\$	2.0	2.0	2.0
6.	Travel expenses, including	60.0K US\$	20.0	20.0	20.0
	a) to nonrouble zone countries		5.0	5	
	б) to cities of rouble zone countries		15.0	15.0	20.0
Total		287.0K US\$	194.0KUS\$	64.0KUS\$	29.0K US\$

PROJECT LEADER

LABORATORY DIRECTOR

LABORATORY CHIEF ENGINEER-ECONOMIST

Изучение свойств нейтрино с помощью
низкофонового германиевого спектрометра GEMMA-III

Проект GEMMA III

ШИФР ТЕМЫ 03-2-1100-2010/2018

АВТОРЫ ОТ ОИЯИ:

Белов В.В., Бруданин В.Б., Егоров В.Г., Житников И.В., Зинатулина Д.Р.,
Лубашевский А.В., Медведев Д.В., Пономарев Д.В., Розов С.В., Розова И.Е.,
Сандуковский В.Г., Фомина М.В., Ширченко М.В., Якушев Е.А..

Объединенный институт ядерных исследований, ЛЯП (Дубна)

РУКОВОДИТЕЛЬ ПРОЕКТА: В.Б. Бруданин.

ЗАМЕСТИТЕЛЕЙ РУКОВОДИТЕЛЯ ПРОЕКТА: А.В.Лубашевский, Е.А.Якушев

ДАТА ПРЕДСТАВЛЕНИЯ ПРОЕКТА В НОО _____

ДАТА НТС ЛАБОРАТОРИИ _____ НОМЕР ДОКУМЕНТА _____

ДАТА НАЧАЛА ПРОЕКТА GEMMA3: январь 2019

(ДАТА ПЕРВОГО УТВЕРЖДЕНИЯ ПРОЕКТА (GEMMA-II) на НТС ЛЯП): 07.02.2014

ЛИСТ СОГЛАСОВАНИЙ ПРОЕКТА

ПОЛНОЕ НАЗВАНИЕ ПРОЕКТА: Изучение свойств нейтрино с помощью
низкофонового германиевого спектрометра GEMMA-III

УСЛОВНОЕ ОБОЗНАЧЕНИЕ ПРОЕКТА ИЛИ КОЛЛАБОРАЦИИ: GEMMA-III

ШИФР ТЕМЫ 03-2-1100-2010/2018

ФИО РУКОВОДИТЕЛЯ ПРОЕКТА: Бруданин Виктор Борисович

УТВЕРЖДЕН ДИРЕКТОРОМ ОИЯИ

СОГЛАСОВАНО

ПОДПИСЬ

ДАТА

ВИЦЕ-ДИРЕКТОР ОИЯИ

ГЛАВНЫЙ УЧЕНЫЙ СЕКРЕТАРЬ

ГЛАВНЫЙ ИНЖЕНЕР

НАЧАЛЬНИК НОО

ДИРЕКТОР ЛАБОРАТОРИИ

ГЛАВНЫЙ ИНЖЕНЕР ЛАБОРАТОРИИ

РУКОВОДИТЕЛЬ ПРОЕКТА

ЗАМ. РУКОВОДИТЕЛЯ ПРОЕКТА

ОДОБРЕН

ПКК ПО НАПРАВЛЕНИЮ

Предлагаемый план-график и необходимые ресурсы для осуществления проекта GEMMA-III

Наименование узлов и систем установки, ресурсов, источников финансирования		Стоимость узлов (тыс.\$). установки. Потребности в ресурсах	Предложения Лабораторий по распределению финансирования и ресурсов			
			1 год.	2 год.	3 год	
Основные узлы и оборудование	1. Криогенное оборудования для детекторов. (Криостаты)	70.0	70.0			
	2. Материалы для калибровок и пассивной защиты.	40.0	25.0	10.0	5.0	
	3. Электроника NIM	50.0	40.0	10.0		
	4. Электроника VME	55.0	35.0	20.0		
	Итого	215.0	170.0	40.0	5.0	
Необходимые ресурсы	Нормо-часы	ООЭП ЛЯП	600	200	200	200
Источники финансирования	Бюджет	Затраты из бюджета	215.0	170.0	40.0	5.0
	Внебюджетные средства	Вклады коллаборантов. Средства по грантам. Вклады спонсоров Средства по договорам. Другие источники и т.д.	45.0	20.0	15.0	10.0

Руководитель проекта:

Смета затрат по проекту «GEMMA-III»

№	Наименование статей затрат	Полная стоимость	1 год	2 год	3 год
Прямые затраты на Проект					
1.	Компьютерная связь	6.0 тыс. \$	2.0	2.0	2.0
2	ООЭП ЛЯП	600 нормо/час	200	200	200
3.	Материалы	40.0 тыс. \$	25.0	10.0	5.0
4.	Оборудование	175.0 тыс. \$	145.0	30.0	
5.	Оплата НИР, выполняемых по договорам	6.0 тыс. \$	2.0	2.0	2.0
6.	Командировочные расходы, в т.ч.	60.0 тыс. \$	20.0	20.0	20.0
	а) в страны нерублевой зоны		5.0	5.0	
	б) в города стран рублевой зоны		15.0	15.0	20.0

Итого по прямым расходам 287.0 тыс.\$ 194.0 тыс.\$ 64.0тыс.\$ 29.0тыс.\$

Руководитель Проекта

Директор Лаборатории

**Ведущий инженер-экономист
Лаборатории**

Investigation of neutrino properties with
the low-background germanium spectrometer GEMMA-III

GEMMA-III

CODE OF THEME 03-2-1100-2010/2018

V.V.Belov, V.B.Brudanin, V.G.Egorov, M.V.Fomina, A.V.Lubashevskiy, D.V.Medvedev,
D.V.Ponomarev, V.G.Sandukovsky, M.V.Shirchenko, S.V.Rozov, I.E.Rozova,
I.V.Zhitnikov, E.A.Yakushev, D.R.Zinatulina

Laboratory of Nuclear Problems, JINR

NAMES OF PROJECT LEADERS: V.B.Brudanin

NAME OF PROJECT DEPUTY LEADERS: A.V.Lubashevskiy, E.A.Yakushev

DATE OF SUBMISSION OF PROPOSAL OF PROJECT TO SOD _____

DATE OF THE LABORATORY STC _____ DOCUMENT NUMBER _____

STARTING DATE OF PROJECT January 2019 (FOR EXTENSION OF
PROJECT — DATE OF ITS FIRST APPROVAL) 07.02.2014

CONTENTS

ABSTRACT	3
INTRODUCTION	4
STATE-OF-THE-ART OF THE INVESTIGATIONS	5
DESCRIPTION OF THE PROPOSED RESEARCH	7
RESULTS FROM THE PREVIOUS INVESTIGATIONS	12
PUBLICATIONS AND REPORTS	14
ESTIMATION OF HUMAN RESORCES	15
SWOT ANALYSIS	16

ABSTRACT

The GEMMA project is aimed to investigate fundamental properties of neutrino at close vicinity of the reactor core of Kalinin Nuclear Power Plant (KNPP). The first phase of the project (GEMMA-I) sets up the world best upper limit for the Magnetic Moment of Neutrino (MMN) of $< 2.9 \cdot 10^{-11} \mu_B$ (90% CL). The search for the coherent scattering of the neutrino from the reactor is also performed within the GEMMA project. This process has never been observed for the low-energy reactor neutrino. While observing, it opens a way to search of the non-standard neutrino interaction and applied research, like reactor monitoring.

The GEMMA-III experimental setup will be constructed under the reactor №3 of KNPP at a distance of 10 m from the center of the core under an enormous antineutrino flux of more than $5 \cdot 10^{13} \nu/\text{cm}^2/\text{s}$. A special lifting mechanism allows to move the detector away from the reactor core, suppressing main systematic errors caused by possible long-term instability and neutrino flux. On the current stage the detector's array consists of four low threshold germanium detectors with a mass of about 400 g each. At JINR it was demonstrated a possibility to reach energy threshold of about 350 eV, which is sufficient to search for the coherent neutrino scattering. Detectors at KNPP will be surrounded by passive and active shielding reducing the external background in the region of interest down to $\sim 1.0 (\text{keV} \cdot \text{kg} \cdot \text{day})^{-1}$. First coherent neutrino scattering from the reactor would be observed in case of desired background level is achieved. New detectors in GEMMA-III project will have an ultimate resolution of about 80 eV (FWHM) with masses of more than 1 kg each. It would allow to explore an energy region down to about 200 eV.

In 2018 new point contact detectors with a total mass of about 5.5 kg will be used for an upgrade of the experimental setup. As a result of the last step the experimental sensitivity will be improved to the level of $\sim 9 \cdot 10^{-12} \mu_B$ after several years of data taking. This setup would also open a way to investigate the coherent neutrino scattering with a much higher sensitivity to the non-standard neutrino interactions. The requested financial support for the project is 287 k\$.

INTRODUCTION

Neutrino plays very important role in modern physics. It was first postulated by Wolfgang Pauli already in 1930, then detected in 1956, but still many properties of it are unknown. Measurement of the neutrino properties is a very important task for particle physics, astrophysics and cosmology. Being one of the most abundant particle in the Universe its detection is very challenging due to a very weak interaction with matter. To investigate its properties, it is required to have a very strong source of the neutrinos and apply various methods for the suppression of background events.

A magnetic moment is the fundamental parameter of the neutrino and its investigation may lead to results beyond the standard concepts of elementary particle physics and astrophysics. The Minimally Extended Standard Model predicts a very small magnetic moment value for the massive neutrino ($\mu_\nu \sim 10^{-19}\mu_B$) that cannot be observed in a present experiment. However, there are a number of theory extensions beyond the Standard Model where magnetic moment of neutrino could be at the level of $10^{-(10+12)}\mu_B$ for Majorana neutrino. The observation of MMN value higher than $10^{-14}\mu_B$ would be an evidence of New Physics and would give an evidence that neutrino is a Majorana particle. Coherent Elastic Neutrino-Nucleus Scattering (CENNS) is a process predicted by the Standard Model, but has not been observed yet for the reactor neutrino. The detection of this process would be an important test of the Standard Model. Such observations can also help for the search of non-standard neutrino interactions, sterile neutrinos and other investigations. Due to a low cross section and a very low energy deposition, it is not easy to observe such a process.

The GEMMA-III is a new experiment aimed to investigate neutrino properties located at KNPP. This experiment is an evolution of our previous projects GEMMA and ν GEN. It is going to move our investigations on a new level of sensitivity. The experimental setup is located at about 10 m from the 3 GW_{th} reactor core allowing to operate a neutrino flux greater than $5 \cdot 10^{13}$ per cm² per second. The available place for the measurement is located just under the reactor, which provides about 50 m w.e. shielding from cosmic rays. A low threshold germanium diodes are used for the detection of neutrino via its scattering on germanium nucleus. A low background environment including passive shielding and active μ -veto is constructing around the detectors helping to reduce the background level. For the confirmation of signal, the experiment is using differential type of measurements and some experimental techniques. Energy spectra received with working and stopped reactor will be compared. Apart from this, the experimental setup is located on a movable platform allowing measurements at different distances (from 10 to 12.5 m) from the reactor. Currently in ν GEN experiment we are using four low background germanium detectors with a small point contact allowing investigation at very low energy. They has been tested at the underground laboratory, where a background level of about 1 cts/(keV·kg·day) has been achieved. The experimental energy thresholds set by discriminators are below 400 eV. In GEMMA-III project we are planning to increase sensitivity of the experiment by using new detectors with higher masses and lower thresholds. Several low-background detectors with a mass more than 1 kg each will be used. These point contact detectors produced by CANBERRA would have much better resolution (about 80 eV FWHM) and thus much better energy threshold needed for the detection of signal from the neutrino scattering. We are planning to increase a total detector mass up to about 5.5 kg, thus the sensitivity for the magnetic moment of the neutrino would be about $9 \cdot 10^{-12}\mu_B$ after several years of data taking.

STATE-OF-THE-ART OF THE INVESTIGATIONS

In the Minimum Extended Standard Model the MMN is expressed in terms of the neutrino mass m_ν :

$$\mu_\nu = \frac{3eG_F}{8\pi^2\sqrt{2}} \cdot m_\nu \approx 3 \cdot 10^{-19} \mu_B \cdot \frac{m_\nu}{1eV}, \quad (1)$$

where μ_B is the Bohr magneton ($\mu_B = e \cdot h / 2m_e$). The review on electromagnetic properties and interactions of neutrinos can be found in [1]. There are several different approaches to search the magnetic moment of the neutrino. One of the approaches is to use data from solar neutrino experiments. Recently investigation by BOREXINO experiment setup up a new limit on an effective magnetic moment of neutrino of $\mu_\nu^{eff} \leq 2.8 \cdot 10^{-11} \mu_B$ [2]. This limit has been set using constraints on the sum of the solar neutrino fluxes implied by the radiochemical gallium experiments. The image about the value of MMN can be obtained by the stellar parameters analysis on the last stage of their evolution when the neutrino fluxes carry out almost all the energy that the stars lose. From such parameter estimation like He star mass at the outburst moment, luminosity of white dwarfs and the energy spectrum of neutrino from supernova explosion one can get the limit $\mu_\nu \leq (0.01 \div 0.1) \cdot 10^{-10} \mu_B$ [3]. The results are model dependent. That's why it is very important to increase the sensitivity of the present laboratory measurements of MMN as it could check the hypothesis about the existence of anomaly huge magnetic moment that goes out of the framework of Standard Model.

The measurements that are carried out with the GEMMA-I spectrometer [4,5,6] using High Purity germanium detectors at the 3 GW_{th} reactor of Kalinin Nuclear Power Plant (KNPP) give the present world best upper limit on MMN at the level of $2.9 \cdot 10^{-11} \mu_B$. Using passive and active methods of the background suppression in GEMMA-I experiment it was possible to achieve background level at the low energy region of ~ 2.5 cts/(keV·kg·day)⁻¹. The effective energy threshold was about 2.8 keV. The aim of the present project is to construct a spectrometer with better experimental parameters to be more sensitive to the possible effect.

Several serious improvements were considered to increase the level of sensitivity of GEMMA-I. We moved our experiment to the another experimental room, which is located closer to the reactor core. The distance to the reactor core is only 10 m. This allows to double a flux that was in GEMMA-I. The value of the neutrino flux is more than $5 \cdot 10^{13}$ v/(s·cm²) – the highest value in the field. Moreover, the location in the experimental room under the reactor core provides of about 50 m w.e. of overburden serving as a good shielding against cosmic radiation. The new room where the experiment take place is not connected with the reactor containment, so the concentration of radioactive noble gases will be greatly reduced and that will allow to avoid problems with ¹³³Xe observed in GEMMA-I. The room also has no contamination of ¹³⁷Cs and ⁶⁰Co isotopes and climate conditions are much better and more stable. Thus we are planning to improve the background index that was in GEMMA-I experiment. It is expected to be $\sim (0.5-1)$ cts/(keV·kg·day)⁻¹. Another improvement is connected with energy threshold of germanium detectors. In GEMMA-III we are planning to use detectors with a resolution of about 80 eV (FWHM), thus it is the effective threshold would be below 200 eV. The total detector mass would be about 5.5 kg, thus the sensitivity of the magnetic moment of the neutrino would be about $9 \cdot 10^{-12} \mu_B$ after several years of data taking.

The detection of low energy neutrinos via CENNS on a nuclear target is a sought-after goal in modern neutrino physics. This mode of neutrino interaction with matter is well allowed in the Standard Model and its cross section is enhanced by several orders of magnitude being proportional to the number of nuclear target neutrons squared, N^2 [7], [8]. While being conceptually highly interesting and allowing measurements of electroweak

observables at low momentum transfer, the process is also of phenomenological importance for future dark matter direct detection experiments [9]. Moreover, it provides precision test of neutrino interactions in the Standard Model and strong constraints on new physics related to neutrinos and may holds the potential to probe new neutrino physics [10]. A technology of detection of neutrinos via coherent scattering would also help to develop neutrino based applied research in future (for example, non-intrusive monitoring of nuclear reactors). Any detection of recoil nuclei due to the coherent neutrino scattering is an extremely challenging task mainly due to a tiny energy transfer from neutrino to the nucleus (less than 600 eV recoils for the germanium). The search for CENNS is performed by a lot of different experiments using: superconducting detectors, noble liquids, inorganic scintillators and others. Very recently collaboration COHERENT claimed that they have observed coherent neutrino scattering from accelerator [11]. However, the results were obtained with relatively high energy neutrinos, close to the coherency limit. More precise investigations with low energy neutrinos are required to prove their results. We are planning to do this by measuring of CENNS from the reactor neutrinos.

Based on the experience of GEMMA-I we started investigation of CENNS process within the vGeN experiment at KNPP [12]. Four HPGe low-energy threshold detectors (~400 grams each) produced in cooperation between JINR (Dubna) and BSI (Riga) are used for the detection of CENNS. The vGeN HPGe detectors were tested in the LSM laboratory in a low-background passive shield made of copper and lead. The achieved background level was about $1 \text{ cts}/(\text{keV}\cdot\text{kg}\cdot\text{day})^{-1}$. The effective energy threshold of about 350 eV has been archived in our test measurements. With such parameters we are planning to detect up to tens of events corresponding to neutrino coherent scattering on Ge nuclei per day. At the same time, for GEMMA-III we will use new detectors produced by CANBERRA [13] which has an effective threshold of about 200 eV. This would open up the possibility to make fundamental tests of the neutrino properties [10].

- [1] C.Giunti, A.Studenikin, "Electromagnetic interactions of neutrinos: a window to new physics", Rev. Mod. Phys. 87 (2015) 531.
- [2] M. Agostini et al., "Limiting neutrino magnetic moments with Borexino Phase-II solar neutrino data", arXiv:1707.09355 [hep-ex].
- [3] G.G. Raffelt, Phys. Rep. 320, 319 (1999); M. Fukugita, preprint Yukawa Institute Kyoto UITP/K-1086 (1994), "Neutrinos in Cosmology and Astrophysics".
- [4] Beda A. G., et al., // Phys. At. Nucl. 2007. V.70. P.1873;
- [5] Beda A. G., et al.,// Phys. At. Nucl. 1998. V.61. P.66.
- [6] Beda A. G. et al. // Phys. At. Nucl. 2004. V.67. P.1948; hep-ex/9706004.
- [7] A. Drukier and L. Stodolsky, Principles and Applications of a Neutral Current Detector for Neutrino Physics and Astronomy, Phys. Rev. D 30 (1984) 2295.
- [8] D.Z. Freedman, Coherent neutrino nucleus scattering as a probe of the weak neutral current, Phys. Rev. D 9 (1974) 1389.
- [9] J. Billard, L. Strigari, and E. Figueroa-Feliciano, Phys. Rev. D89, 023524 (2014), arXiv:1307.5458 [hep-ph].
- [10] Lindner, M., Rodejohann, W. & Xu, XJ. J. High Energ. Phys. (2017) 2017: 97. [https://doi.org/10.1007/JHEP03\(2017\)097](https://doi.org/10.1007/JHEP03(2017)097).
- [11] D. Akimov et al., Observation of coherent elastic neutrino-nucleus scattering, Science 15 Sep 2017:Vol. 357, Issue 6356, pp. 1123-1126
- [12] V. Belov et al., "The vGeN experiment at the Kalinin Nuclear Power Plant", 2015 JINST 10 P12011.
- [13] P.Quirin, TAUP 2017, https://indico.cern.ch/event/606690/contributions/2591653/attachments/1497114/2329910/Mirion_TAUP_2017_V2.pdf

DESCRIPTION OF THE PROPOSED RESEARCH

The GEMMA-III experiment will investigate the fundamental properties of the neutrino using HPGe detectors placed in a close vicinity of the powerful nuclear reactor. The collaboration consists of scientists from JINR (Dubna), ITEP (Moscow) and MEPHI (Moscow). Mainly it focused on the searches of MMN and CENNS. However, some other scientific directions are also considered.

A laboratory measurement of the MMN is based on its contribution to the ν -e scattering. For non-zero MMN the ν -e differential cross section is a sum of weak interaction cross section ($d\sigma^W/dT$) and electromagnetic one ($d\sigma^{EM}/dT$):

$$d\sigma^W/dT = G_F^2 \cdot (m_e/2\pi) \cdot [4x^4 + (1 + 2x^2)^2 \cdot (1 - T/E)^2 - 2x^2(1 + x^2) m_e T/E^2], \quad (2)$$

$$d\sigma^{EM}/dT = \pi r_0^2 (\mu_\nu / \mu_B)^2 (1/T - 1/E), \quad (3)$$

where E is the incident neutrino energy, T is the electron recoil energy, $x^2 = \sin^2\theta_W = 0.232$ is a Weinberg parameter and r_0 is a classical electron radius ($\pi r_0^2 = 2.495 \times 10^{-25} \text{ cm}^2$). One can see that at low recoil energy ($T \ll E_\nu$) the value of $d\sigma^W/dT$ becomes almost constant while $d\sigma^{EM}/dT$ increases as T^{-1} . It becomes evident that the lower detector threshold is the more considerable increase in the MMN effect with respect to the weak irremovable contribution we can obtain.

The basic challenge of the experiment is to decrease the level of background for shallow setup down to the level $0.5 \div 1 \text{ (keV}\cdot\text{kg}\cdot\text{day)}^{-1}$, comparable with the background achieved for deep underground setups. Taking into account this goal we have chosen the construction of low background setup including an active shielding which can provide maximum suppression of all cosmic ray background components. Various approaches to solution of this problem were analysed during development of the spectrometer. Spectrometers with pure passive shielding and Ge-Nal spectrometers were also considered. The latter option was chosen as it allowed maximum reduction of all background components under condition of strong cosmic radiation.

The detection of low energy neutrinos via coherent neutrino scattering on a nuclear target is well allowed in the Standard Model and its cross section is enhanced by a several orders of magnitude being proportional to the number of nuclear target neutrons squared N^2 :

$$\frac{d\sigma}{d\Omega} \simeq \frac{G_F^2}{16\pi^2} E_\nu^2 (1 + \cos\theta) N^2 F^2(Q^2) \quad (4)$$

Here, E_ν is the neutrino energy, θ is the scattering angle, Q is the transferred momentum, $Q^2 = 2E_\nu^2(1 - \cos\theta)$, G_F is Fermi constant and $F(Q^2)$ is the elastic nuclear form-factor, which strongly vanishes out the coherent effect with Q increase ($F(Q^2) \propto e^{-R^2 Q^2/6}$), R is the nucleus radius). The large coherent scattering enhancement of the cross-section results in expected nuclear recoil rates to be at the level of tens events per kilogram of matter per day for antineutrinos produced by a typical industrial reactor and a detector placed in ~ 10 m from the reactor core. As a result one can significantly reduce the size and mass of the relevant neutrino detector. Therefore, developing the technology for detection of neutrinos via the coherent scattering is one of the priorities for neutrino physics and would help to develop neutrino based applied research in future (for example, non-intrusive monitoring of nuclear reactors). Any detection of recoiled nuclei due to the coherent neutrino scattering is an extremely challenging task mainly due to a tiny energy transfer from neutrino to the nucleus. The recoil energy for Ge nuclei from reactor antineutrinos is $\lesssim 3$ keV. Only a small fraction (about $\sim 20\%$) of this kinetic energy of the recoil nucleus is converted into energy of ionizing radiation, i.e. detected ionization will be only $\lesssim 600$ eV.

Reactor neutrinos are referred because among all artificial neutrino sources nuclear reactors provide the largest (anti)neutrino flux up to about 10 MeV, thus reactor neutrinos are able to interact coherently with atomic nuclei. We can place our experimental setup at

the distance of about 10 m from the 3 GW_{th} reactor's core. The neutrino flux at this place is up to about $5 \cdot 10^{13}$ neutrinos per s per cm². This is the highest flux available among the existing experiments. The scheme of the reactor is shown in Fig.1, left.

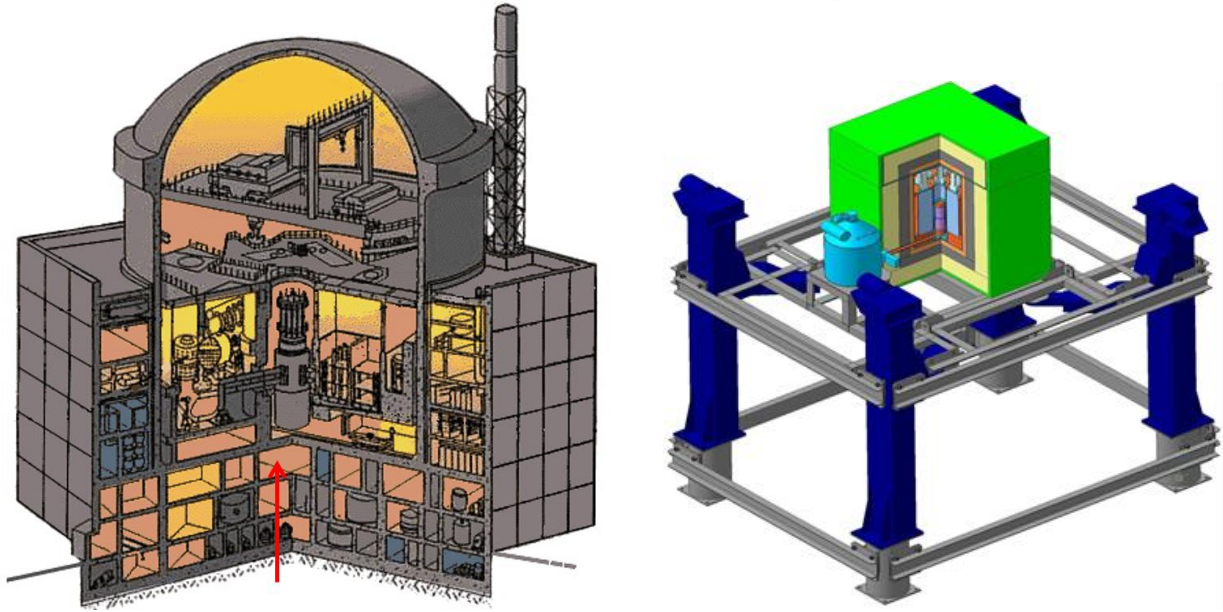

Figure 1. Left: the scheme of the reactor unit #3 at KNPP. Arrow indicates the room where experimental setup is being constructed. Right: the scheme of the spectrometer placed on the lifting mechanism.

Experimental setup is located under the reactor core #3. Constructing materials serve as shielding against cosmic radiation (50 m w.e.), so hadronic component of the flux is greatly reduced. The expected number of events depends on neutrino energy spectrum and flux, detector mass and duration of measurements. Number of expected event would be compared with the background expectations. To prove that observed excess is caused by neutrino several methods of analysis will be used. The first is the comparison between the count rates during reactor ON/OFF regimes and comparison with the background predictions. Second method is based on the idea of changing the neutrino flux by moving experimental setup towards and away from the reactor core. For this purpose a special tool has been developed and installed in the experimental room. The scheme of experimental setup and lifting mechanism is shown on Fig.1, right. To achieve the desired goal of coherent neutrino detection in the vGEN experiment we use four low background HPGe detectors (Fig. 2) with modified p⁺ contact produced in cooperation between JINR (Dubna) and BSI (Riga).



Figure 2. Photo of four HPGe point contact vGen detectors.

The total mass of the detectors is about 1.6 kg. The detectors are placed inside a low background U-type cryostat (see Fig. 3).

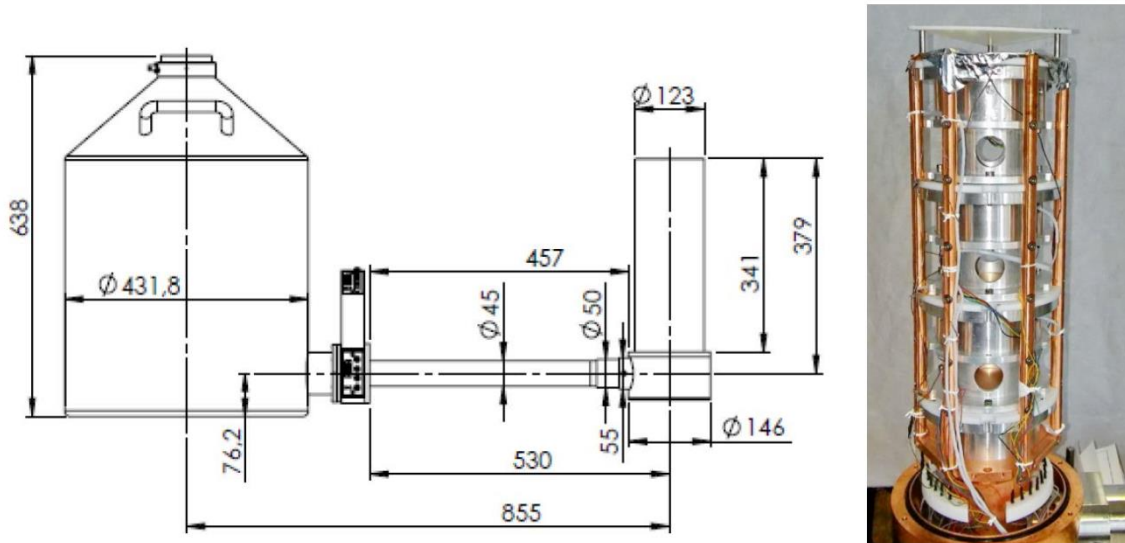

Figure 3. Left: General scheme of the vGeN cryostat for 4 HPGe detectors. Right: Photo of the internal part that includes holders for 4 HPGe detectors.

The main materials used for the cryostat are ultra-pure aluminium and copper. Using of indium for thermo/electrical contact was totally avoided. All materials used for production of the cryostat were selected after gamma-screening for radioactivity of 50 samples. Everything from raw aluminium, stainless steel, Teflon and polycarbonate to bolts, nuts, wires, supports, O-rings of different sizes has been tested. The gamma radioactivity screening has been performed with OBELIX HPGe detector installed in the LSM underground laboratory (Modane, France).

The vGeN HPGe detectors were tested at the LSM laboratory in a low-background passive shield made from copper and lead. Simplified acquisition system was used during the tests. ADC channel to energy scale conversion was performed with a calibration by 10.37 keV and 1.3 keV cosmogenic lines assuming linearity of the scale. The energy resolutions (FWHM) for 10.37 keV line for detectors N1-N4 were found to be 230 ± 10 eV, 270 ± 10 eV, 230 ± 10 eV and 220 ± 10 eV, respectively.

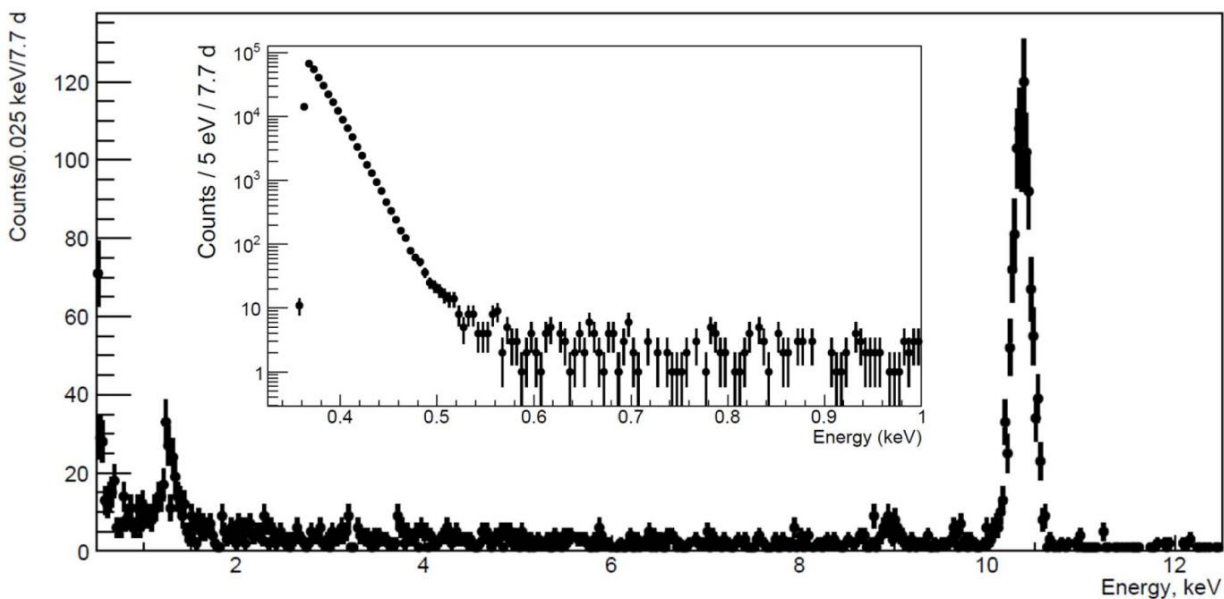

Figure 4. The low energy spectrum for detector N4. The energy scale was calibrated with clearly detected 1.3 keV and 10.37 keV cosmogenic lines. The low energy part of the spectrum is shown as the insert with the logarithmic scale.

Fig. 4 demonstrates the experimental low energy spectrum for one of the detectors. For the energy region from 100 to 600 keV the background index was found to be 0.66 ± 0.03 cpd/(kg·keV). For the region from 20 to 100 keV it is 1.11 ± 0.07 cpd/(kg·keV). In the region of interests for detection of coherent neutrino scattering (around 500 eV) several events per day are detected (see Fig. 5).

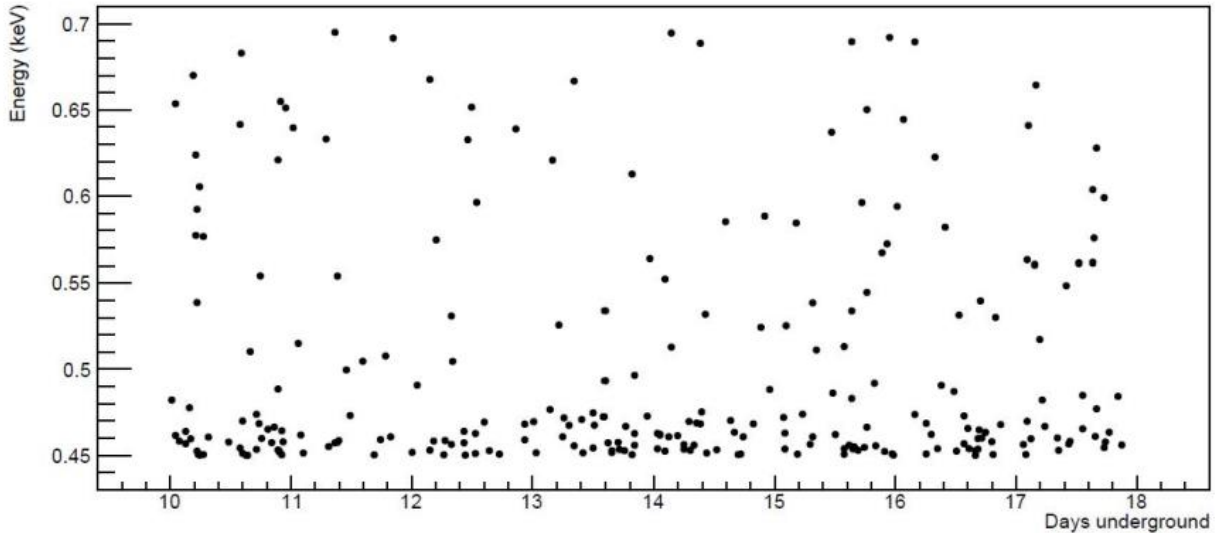

Figure 5. Events detected by one detector during 7.7 days. Only low energy part from 0.45 to 0.7 keV region is shown.

The main conclusion of the performed tests is that achieved energy thresholds and preliminary values of the experimental background are adequate in order to start further commissioning of the setup with proper acquisition chain and the veto systems at the KNPP experimental site.

After radiopurity tests at LSM, detectors were moved to JINR (Dubna). A new acquisition system has been installed. Signal from germanium detector currently are taken by means of real time ADC. The best energy resolution achieved with a pulse generator is about 170 eV (FWHM). The noise events are being suppressed by comparing signals reconstructed with different shaping times of amplifiers (see Fig. 6). Periodical noise is suppressed by the time cut.

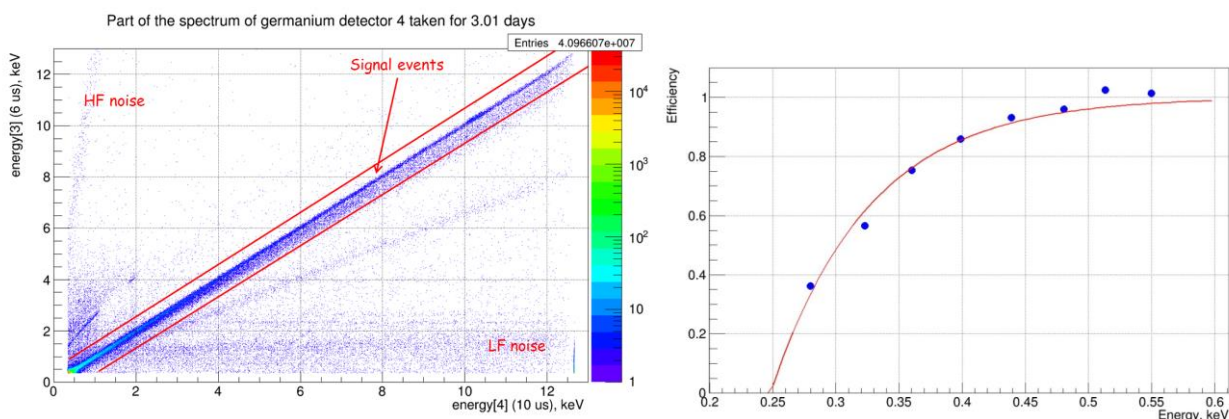

Figure 6. Left: Example of the Fourier analysis made with different shaping times. Right: survival fraction of the events from pulse generator after applying all the cuts

Calibration with a pulse generator demonstrates that after applying all cuts it is still possible to detect events with energy below 350 eV with an efficiency of about 70%. This should be sufficient for detection of CENNS.

After these tests the spectrometer was moved to the experimental room at KNPP. Currently we are constructing a passive shielding around of ν GEN spectrometer. Photos from the construction phase are shown in Fig. 7.

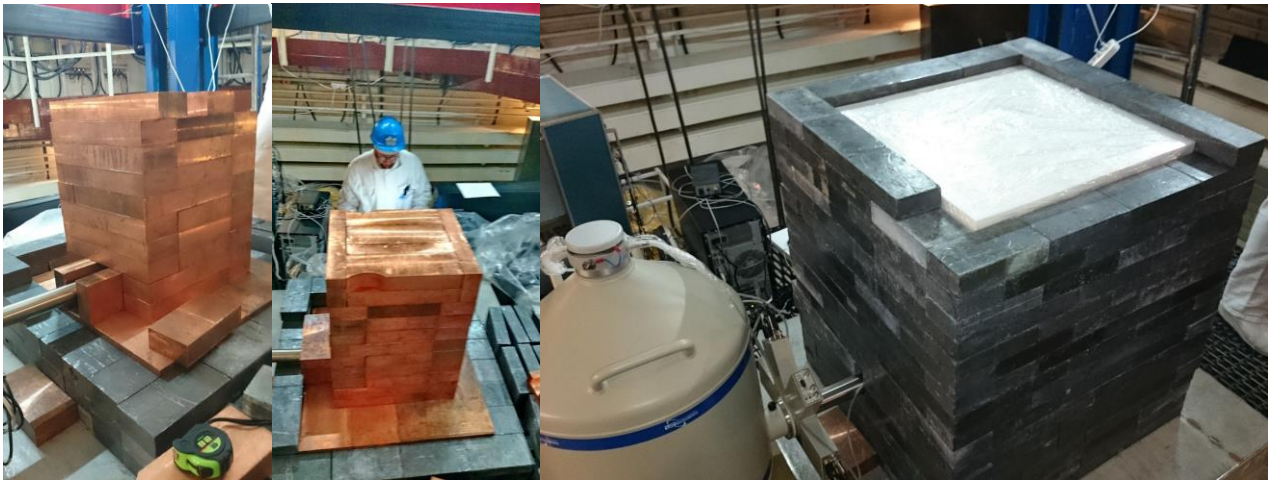

Figure 7. Photos from the construction phase of the ν GEN spectrometer under KNPP reactor.

The data taking for the CENNS is going to start this year.

At the same time, we are planning to increase the sensitivity of the experiment by using detectors with a higher masses and lower threshold. Such an upgrade is called GEMMA-III project. Recent development on a detector production allows us to produce detectors with significantly higher resolution than it was achieved before. New detectors produced by CANBERRA have resolution below 80 eV (FWHM) with masses of a few kg. It is possible to work with an energy threshold below 200 eV with them. This energy threshold increase greatly the number of events from neutrino scattering and increase its sensitivity.

Using all infrastructure developed for ν GEN experiment we are going to swap existing ν GEN cryostat by a newly produced CANBERRA detectors. The first 1 kg detector after successful testing at LSM will arrive to JINR in the beginning of 2018. After its arrival we are planning to move it to KNPP and replace ν GEN spectrometer. Altogether, we are planning to use four detectors with a total detector mass of about 5.5 kg. The detectors should be ready in the end of 2018. This would allow to detect of about 190 events from CENNS per day. The sensitivity to magnetic moment of the neutrino would be about $9 \cdot 10^{-12} \mu\text{B}$ after several years of data taking.

Thus, the project GEMMA-III is the continuation of predecessor projects GEMMA and ν GEN. Mostly it is performed by physicists from DLNP (JINR, Dubna) with a collaboration with ITEP (Moscow) and MEPhI (Moscow). By previous steps it was demonstrated that our group is able to perform modern investigations with HPGe detectors achieving very low background level on a shallow depth. The limit on a magnetic moment of the neutrino obtained in the GEMMA-I experiment is the best in the world so far beyond the terrestrial experiments. We are going to continue our studies and improve our knowledge on the neutrino parameters.

RESULTS FROM THE PREVIOUS INVESTIGATIONS

Investigation at KNPP by JINR group has a long successful history. Fig.8 shows scheme of GEMMA-I spectrometer constricted at KNPP.

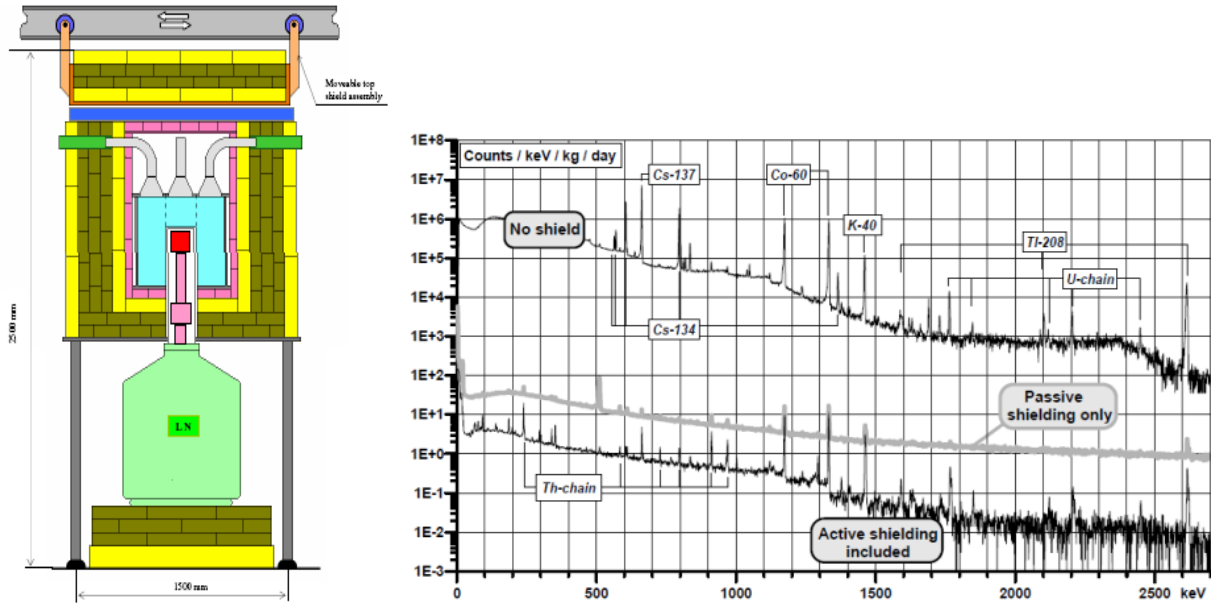

Figure 8: Left: scheme of GEMMA-I spectrometer. Right: Gamma-spectra measured at the detector site under different shielding conditions.

The experimental spectra obtained in this project are shown on Fig.8, right. The background level of about $2.5 \text{ counts}/(\text{keV}\cdot\text{kg}\cdot\text{day})^{-1}$ has been achieved with the GEMMA-I experiment. Taking data for about 4 year (see Fig. 9) it was possible to set up the world best limit on a MMN of $< 2.9 \cdot 10^{-11} \mu_B$.

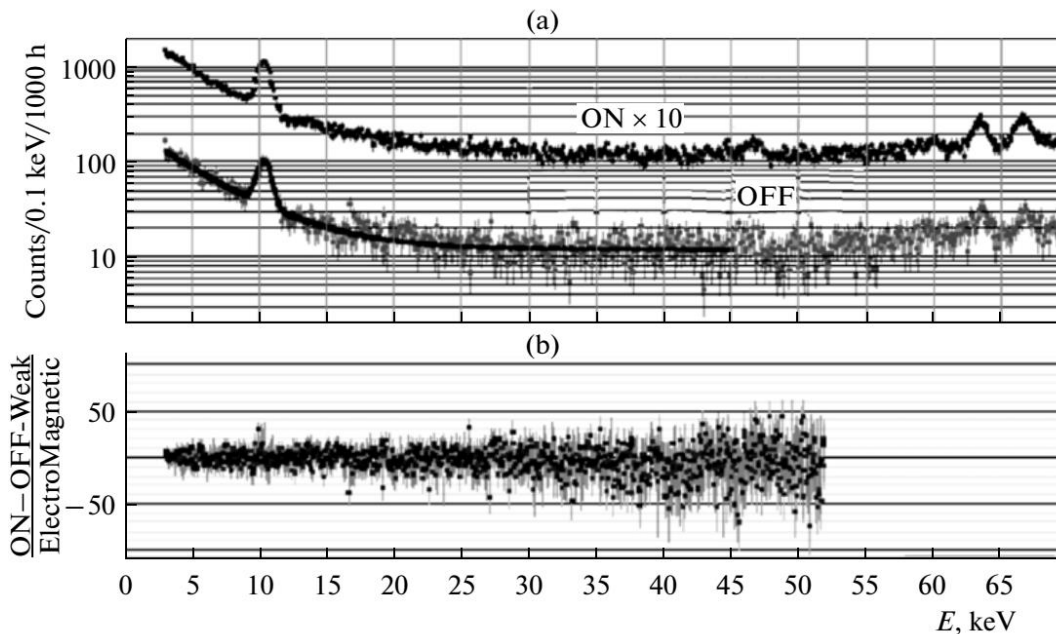

Figure 9. Fragments of the experimental ON and OFF spectra (a) and their difference normalized by the electromagnetic cross section (b)

As the limit of sensitivity for GEMMA-I spectrometer seems to be reached it is decided to upgrade it to GEMMA-II with better experimental parameters. Two HPGe detectors with the total mass of 6 kg were used for the project. This mass is about 4 times more than for the GEMMA-I spectrometer. However, a significant contamination of the components of the detectors was found after the production. This does not allow to achieve the desired background level in GEMMA-II. At the same time JINR group is focused on the ν GEN experiment building a cryostat with low-threshold germanium detectors aimed for the CENNS search (see Fig.10).

During our investigations we screened of about 50 components and found the source of the contamination for GEMMA-II project. After all these investigations a new ν GEN spectrometer was produced. We performed a special test at LSM underground laboratory with a novel spectrometer. It was surrounded by low background shielding previously used for EDELWEISS-I experiment.

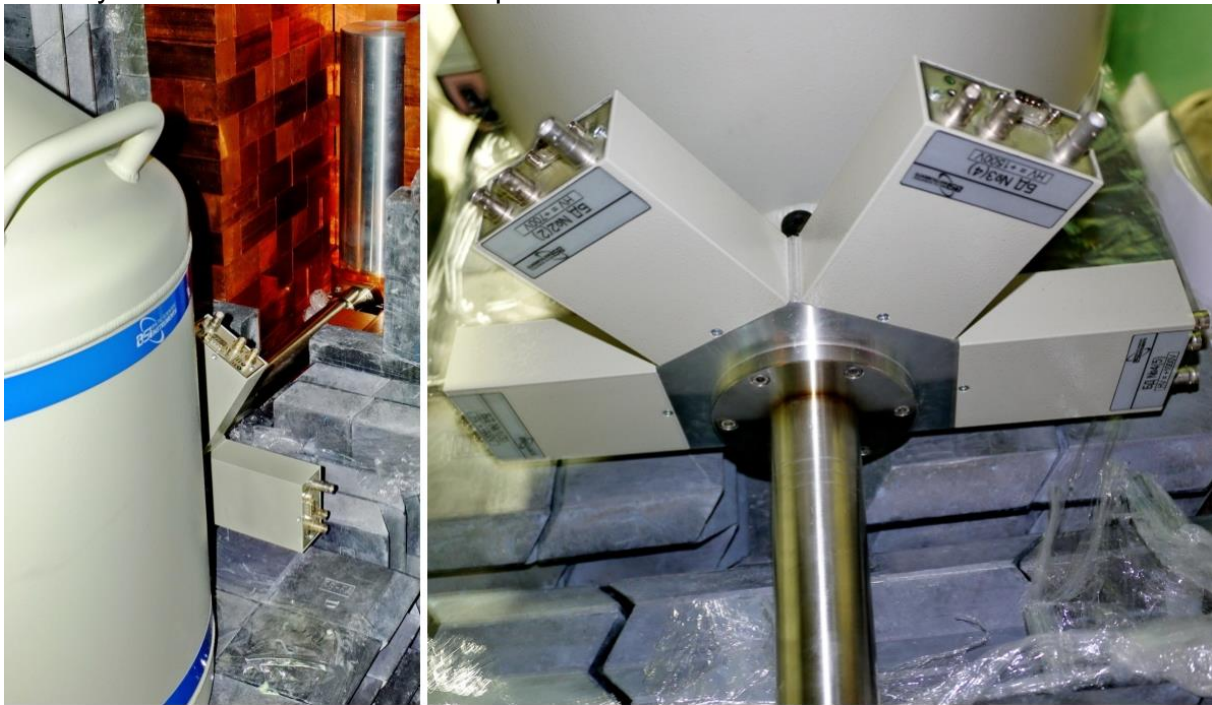

Figure 10. Left: Photo of the ν GeN cryostat. Right: Four preamplifiers attached to the cryostat.

The obtained background level at LSM was about $1.0 \text{ (keV}\cdot\text{kg}\cdot\text{day)}^{-1}$ – this level of background would be sufficient for our studies at KNPP. The energy resolutions (FWHM) for 10.37 keV line for detectors N1-N4 were found to be $230\pm 10 \text{ eV}$, $270\pm 10 \text{ eV}$, $230\pm 10 \text{ eV}$ and $220\pm 10 \text{ eV}$, respectively. The possibility to achieve energy threshold of the detectors at the level of 350 eV has been demonstrated during measurements at JINR. This threshold should be sufficient for CENNS detection. If we will be able to achieve these parameters at reactor site, about ten events corresponding to neutrino coherent scattering on Ge nuclei are expected to be detected per day with signal to background ratio of about factor of 10.

Experience, methods and the materials from ν GEN experiment and previous experiments will be used for GEMMA-III project.

PUBLICATIONS AND REPORTS

- [1] Beda A. G., Brudanin V. B., Demidova E. V., Vylov Ts., Gavrilov M. G., Egorov V. G., Starostin A. S. and Shirchenko M. V. // Phys. At. Nucl. 2007. V.70. P.1873; hep-ex/0705.4576.
- [2] Beda A. G. et al. // Phys. At. Nucl. 2004. V.67. P.1948; hep-ex/9706004.
- [3] Beda A. G. et al. // Advances in High Energy Physics V.2012 (2012), Article ID 350150, 12 pages doi:10.1155/2012/350150
- [4] Alekseev I. et. al. // arXiv:1305.3350, 2013
- [5] A. Beda et al. GEMMA experiment: three years of the search for the neutrino magnetic moment, Physics of Elementary Particles and Atomic Nuclei Letters, 2010, V.7, №6(162), pp.667-672
- [6] A. Beda et al. GEMMA experiment: the results of neutrino magnetic moment search, Physics of Particles and Nuclei Letters, 2013, V.10, №2, pp.139-143
- [7] A. Beda et al. Experiment GEMMA: Search for the Neutrino Magnetic Moment, 2010, Proceedings of Science, №297
- [8] A. Beda et al. Upper limit on the neutrino magnetic moment from three years of data from the GEMMA spectrometer, 2010, arXiv:1005.2736v1
- [9] A. Beda et al. GEMMA experiment: three years of the search for the neutrino magnetic moment, 2009, arXiv:0906.1926v1
- [10] A. Beda et al. The new result of the neutrino magnetic moment measurement in the GEMMA experiment, proceedings of the 13th Lomonosov Conference on Elementary Particle Physics, 2007
- [11] V. Belov et al., "The vGeN experiment at the Kalinin Nuclear Power Plant", 2015 JINST 10 P12011.

Contributions on conferences and workshops

1. D. Medvedev, The International Workshop on Non-Accelerator New Physics (NANPino-2013), Valday, Russia, 2013
2. D. Medvedev, Sixteenth Lomonosov Conference on Elementary Particle Physics, Moscow State University, Moscow, Russia, 2013
3. D. Medvedev, Wilhelm and Else Heraeus-Seminar Exploring the neutrino sky and fundamental particle physics on the Megaton scale, Bad Honnef, Germany, 2013
4. D. Medvedev, Wilhelm and Else Heraeus-Seminar Exploring the neutrino sky and fundamental particle physics on the Megaton scale (poster), Bad Honnef, Germany, 2013
5. V. Egorov, Symposium on JINR-SA collaboration, South Africa, 2012
6. D. Medvedev, JINR neutrino program, Dubna, Russia, 2013
7. D. Medvedev, The International Workshop on Prospects of Particle Physics: "Neutrino Physics and Astrophysics", JINR, INR, Valdai, Russia, 2014
8. D. Medvedev, AYSS 2016, Alushta, Russia, 2016
9. V. Belov, A. Kuznetsov, D. Medvedev, ISAAP, Milan, Italy, 2016
10. V. Belov, A. Kuznetsov, D. Medvedev, ISAAP, Arenzano, Italy, 2017
11. A. Lubashevskiy, ICSSNP 2017, Nalchik, Russia, 2017
12. D. Medvedev, ICSSNP 2017, Nalchik, Russia, 2017
13. A. Lubashevskiy, ISSP 2017, Erice, Italy, 2017

ESTIMATION OF HUMAN RESOURCES

The collaboration consists of scientists from JINR, ITEP and MEPhI. The list of the involved people is shown below:

JINR (Dubna):

V.V.Belov, V.B.Brudanin, V.G.Egorov, M.V.Fomina, A.V.Lubashevskiy, D.V.Medvedev, D.V.Ponomarev, M.V.Shirchenko, S.V.Rozov, I.E.Rozova, I.V.Zhitnikov, E.A.Yakushev, D.R.Zinatulina

ITEP (Moscow):

A. G. Beda, A. S. Starostin

MEPhI (Moscow)

Yu.B.Gurov

Detail information about JINR group human resources:

Name	Category	Responsibilities	Time that each participant will give to the work under the Project in relation to its Full Time Equivalent(FTE)
V. Brudanin	Head of department	Administrative work, project management	0.2
V. Belov	Junior researcher	Muon veto, MC	0.2
V. Egorov	Head of sector	Management, constructions, data analysis	0.3
M. Fomina	Junior researcher	Muon veto, MC	0.3
A. Lubashevskiy	Senior Researcher	Data analysis, MC, and administrative work	0.5
D. Medvedev	Reseacher	Data analysis, MC	1.0
D. Ponomarev	Engineer	Constructions, detectors building, testing. Experiment running.	1.0
M. Shirchenko	Reseacher	Experiment running. Data analysis	0.3
V.Sandukovsky	Head of sector	Detector configuration, constructions	0.5
S. Rozov	Engineer	Detector building, testing, calibration, running.	0.5
I. Rozova	Engineer	Data analysis, constructions	1.0
I. Zhitnikov	Junior researcher	Experiment running, data analysis	0.2
E. Yakushev	Head of sector	Building, commissioning, running, data analysis	0.3
D. Zinatulina	Reseacher	Muon veto, MC	0.2
Total FTE (Engineers): 2.5, Total FTE (Scientific staff): 3.9, Total FTE: 6.4			

SWOT ANALYSIS

Strengths, Weaknesses, Opportunities, Threat (SWOT) analysis of GEMMA-III project is discussed below.

The investigation of the properties of the neutrino attracts interests of many experimental group around the Earth. Many scientists put their efforts in this field and the level of competition is very high. Due to this factor it is possible that somebody can obtain better experimental result than we would do. This is one of the main threats of our project. But nevertheless this gives a good opportunity to do interesting investigation on the first edge of the neutrino physics. The results obtained in this project may open up the possibility for another fundamental or applied investigations of neutrino properties. For example, searches for the fundamental non-standard neutrino interactions or applied research, like reactor monitoring.

Our group has proved capability to achieve the best experimental results in the world, setting up a best limit on the MMN. The big strengths of our project is the possibility to perform investigations with the enormous antineutrino flux of more than $5 \cdot 10^{13} \nu / (\text{cm}^2 \cdot \text{s})$. Moreover, the most dangerous cosmic background in the experimental room is strongly suppressed by the reactor building and various materials inside it. This is very suitable conditions to build an experiment for testing of fundamental properties of neutrino. In comparison with other projects we have possibility to use lifting mechanism that allows us to change the neutrino flux from the reactor by moving the spectrometer away from the core, reducing systematical errors. This is important due to the fact that sought signals typically have a signature similar to background or noise components. Personnel and administration of KNPP greatly supports our activities, however we cannot completely exclude potential difficulties at KNPP due to changes of regulation, rules etc. So this is a possible weakness of the project.

Our group at DLNP JINR holds huge expertise connected with different low background projects. Our division participates in many big international experiments for dark matter and neutrinoless double beta decay searches. Such interconnection gives us a big advantage of having the modest expertise and access to the recent developments in low background technique. From previous experiment we have some low-background materials available and they can be used for the construction of a new experiment.

And one of the most important strength of our project is people. The core group of the project is relatively young people, however already with a good experience in the neutrino physics and low-background projects. Many people have experience working for international collaborations. The investigations are leaded by big experts in the field. So there is good balance between youth and experience in this project.