

УТВЕРЖДАЮ

Вице-директор ОИЯИ

“ \_\_\_\_\_ ” \_\_\_\_\_ 20 г.

**НАУЧНО-ТЕХНИЧЕСКОЕ ОБОСНОВАНИЕ НА ОТКРЫТИЕ НОВОЙ (ПРОДЛЕНИЯ)  
ТЕМЫ  
для включения  
В ПРОБЛЕМНО-ТЕМАТИЧЕСКИЙ ПЛАН ОИЯИ НА 2019 – 2021 гг.**

Шифр темы 03-2-1100-2010/2021

Лаборатория ЛЯП

Отдел НЭОЯСиРХ

Направление: Ядерная физика (03)

Наименование темы: Неускорительная нейтринная физика и астрофизика

Руководители темы: Бруданин В.Б., Ковалик А., Якушев Е.А.

**Краткая аннотация:**

Поиск и изучение безнейтринной и двухнейтринной мод двойного бета-распада, выяснение природы нейтрино: майорановская или дираковская, определение абсолютных значений нейтринных масс и их иерархии, поиск магнитного момента электронного нейтрино, детектирование когерентного рассеяния реакторных антинейтрино на ядрах, поиск возможных проявлений темной материи в области низких и высоких энергий, изучение галактических и внегалактических нейтринных источников, диффузного нейтринного космологического фона и поиск экзотических частиц (магнитные монополи). Исследование внутриреакторных процессов на КАЭС. Поиск стерильных нейтрино. Спектроскопия ядер, удаленных от полосы бета-стабильности. Развитие новых методов регистрации заряженных и нейтральных частиц.

**Этапы работы (указать год завершения) и ожидаемый результат по завершении темы:**

2019-2021 гг, аннотации темы и проектов прилагаются.

**Список участников и организаций:** Армения, Бельгия, Болгария, Великобритания, Германия, Испания, Казахстан, Монголия, Польша, Россия, Румыния, Словакия, США, Узбекистан, Украина, Франция, Финляндия, Чехия

Сроки выполнения работы: 2019-2021

Полная сметная стоимость темы, тыс. USS: 10648,1

СОГЛАСОВАНО:

Главный ученый секретарь

\_\_\_\_\_/\_\_\_\_\_  
" \_\_\_\_ " \_\_\_\_\_ 201 г.

Директор лаборатории

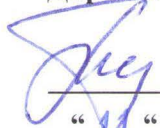
 Бедимов В.А.  
" 11 " декабря 2017 г.

Начальник Планово-финансового отдела

\_\_\_\_\_/\_\_\_\_\_  
" \_\_\_\_ " \_\_\_\_\_ 201 г.

Ученый секретарь лаборатории

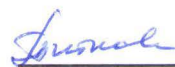
 / Сokolov И.В.  
" 11 " декабря 2017 г.

Начальник научно-организационного отдела

\_\_\_\_\_/\_\_\_\_\_  
" \_\_\_\_ " \_\_\_\_\_ 201 г.

/ Экономист лаборатории

 / Кузнецов М.  
" 11 " декабря 2017 г.

С.н.с. Научно-организационного отдела

\_\_\_\_\_/\_\_\_\_\_  
" \_\_\_\_ " \_\_\_\_\_ 201 г.

Руководитель темы

 / Буздakov  
" 11 " декабря 2017 г.

К форме № 21 прилагается Смета затрат по теме

К форме № 21 прилагаются аннотации темы и проектов

APPROVED BY  
JINR VICE-DIRECTOR

“ \_\_\_\_\_ ” \_\_\_\_\_ 20

SCIENTIFIC AND TECHNICAL JUSTIFICATION FOR OPENING A NEW (EXTENSION)  
THEME  
to be include in the  
TOPICAL PLAN FOR JINR RESEARCH FOR 2019 – 2021

Theme code 03-2-1100-2010/2021

Laboratory DLNP

Department Nuclear Spectroscopy and  
Radiochemistry

Direction: Nuclear Physics (03)

Theme title: Non-Accelerator Neutrino Physics and Astrophysics

Theme leaders: V. Brudanin, A. Kovalik, E. Yakushev

**Abstract:**

Search for and investigation of double-neutrino and neutrinoless modes of double beta-decay, clarification of the neutrino nature Majorana or Dirac, absolute neutrino mass scale and hierarchies. Search for the neutrino magnetic moment, neutrino-nucleus coherent scattering and Dark Matter. Investigation of galactic and extragalactic neutrino sources, diffusive neutrino cosmic background, search for exotic particles (monopoles). Application of the neutrino detector for a distant investigation of process inside of the reactor core of Kalinin Nuclear Power Plant. Search for sterile neutrinos. Spectroscopy of nuclei far from stability. Development of new methods for charged and neutral particle detection.

**Time interval and expected results:** 2019-2021,

annotations for the theme and for scientific projects are attached.

**Participating Countries, Institutes and International organizations:** Armenia, Belgium, Bulgaria, Czech Republic, Finland, France, Germany, Kazakhstan, Mongolia, Poland, Romania, Russia, Spain, Slovakia, Ukraine, UK, USA, Uzbekistan.

Time interval for the theme: 2019-2021

Total estimated cost of the theme k\$, 10648.1

ENDORSED BY:

CHIEF SCIENTIFIC SECRETARY

\_\_\_\_\_/\_\_\_\_\_/\_\_\_\_\_  
" \_\_\_\_ " \_\_\_\_\_ 201

HEAD OF PLANNING AND FINANCE DEPARTMENT

\_\_\_\_\_/\_\_\_\_\_/\_\_\_\_\_  
" \_\_\_\_ " \_\_\_\_\_ 201

HEAD OF SCIENCE ORGANIZATION  
DEPARTMENT

\_\_\_\_\_/\_\_\_\_\_/\_\_\_\_\_  
" \_\_\_\_ " \_\_\_\_\_ 201

Resp. SCIENCE ORGANIZATION DEPARTMENT

\_\_\_\_\_/\_\_\_\_\_/\_\_\_\_\_  
" \_\_\_\_ " \_\_\_\_\_ 201

LABORATORY DIRECTOR

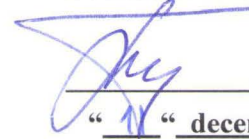
 Begmurob B.A.  
" 11 " december 2017

LABORATORY SCIENTIFIC  
SECRETARY

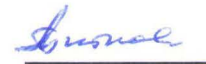
 Ismailov M.B.  
" 11 " december 2017

/ LABORATORY CHIEF ENGINEER-  
ECONOMIST

 Kuznetsov M.P.  
" 11 " december 2017

PROJECT LEADER

 Bopirbekov  
" 11 " december 2017

This Form No. 21 is accompanied by a cost estimate for the theme

This Form No. 21 is accompanied by annotations for the theme and for the projects

## СМЕТА ЗАТРАТ ПО ТЕМЕ

### COST ESTIMATE FOR THE THEME 03-2-1100-2010/2021

бюдж.код	тема	ответств.	описание
1576	1100	Бруданин, Ковалик, Якушев	Неускорительная нейтринная физика и астрофизика (проекты СуперNEMO, БАЙКАЛ, GEMMA-II, EDELWEISS-II, G&M, DANSS)
3821	1100	Бруданин	Проект 'БАЙКАЛ'

Статья	..		Всего
	1576	3821	
<b>1. Заработная плата</b>	1460.0		1460.0
<b>2. Страховые взносы</b>	440.9		440.9
<b>3. Соцбытфонд</b>	94.9		94.9
<b>4. Международное сотрудничество</b>	210.0		210.0
а) командирование в страны-участницы	13.0		13.0
б) командирование в страны-неучастницы	97.0		97.0
в) командирование на территории России	80.0		80.0
г) прием иноспециалистов	5.0		5.0
д) проведение совещаний, представительские расходы	15.0		15.0
<b>5. Материалы</b>	4100.0		4100.0
<b>6. Оборудование</b>	2000.0		2000.0
<b>10. Услуги научно-исследовательских организаций</b>	100.0		100.0
<b>ИТОГО:</b>	8405.8		8405.8
КБ	32.8		32.8
ОЭП	185.4		185.4
Административно-хозяйственные расходы	901.9		901.9
<b>ИТОГО без инфр.ОИЯИ</b>	9525.9		9525.9
Инфраструктура ОИЯИ	1122.2		1122.2
<b>ВСЕГО:</b>	10648.1		10648.1

## **THEME 03-2-1100-2010/2018 AND ITS PROLONGATION FOR 2019-2021**

**THEME TITLE:** NON ACCELERATOR NEUTRINO PHYSICS AND ASTROPHYSICS

**CURRENT THEME CODE:** 03-2-1100-2010/2018

**Leaders:** V.B. Brudanin, A. Kovalik, E.A. Yakushev

### **Preamble:**

The theme “**Non-accelerator neutrino physics and astrophysics**” at JINR is devoted to search and investigation of rare processes by means of nuclear physics methods. The base of the theme is Department of Nuclear Spectroscopy and Radiochemistry, DLNP. This department has a huge almost 50-years experience in high-precision nuclear spectroscopy using semiconductor, scintillator and other types of detectors in general and 30-years experience of rare processes studies in different underground environments. The department has the knowledge, personnel and capabilities to create world-class facilities, conduct measurements with them and obtain world-leading results. At present, the theme consists of six main projects the implementation of which is related to common approaches and resources. In addition to the six scientific sectors involved in the theme, the following resources are available to carry out the scientific projects: the laboratory for the production and repair of semiconductor detectors; laboratory for creation and production of scintillation materials for detectors; radiochemical sector (creation of calibration radioactive sources, purification of materials designated for low-background measurements from their contamination by natural radioactivities, etc.), mechanical workshops, a group of computer support, a group of mass separators and others.

The problems targeted by scientific projects are: neutrino-less double beta decay (SuperNEMO and GERDA (G&M) projects), experiments with the reactor antineutrino: GEMMA-III – search for the neutrino magnetic moment and neutrino coherent scattering; DANSS – reactor diagnostics and investigation of the neutrino properties, direct search for the Dark Matter (EDELWEISS project), deep-water investigations with the neutrino telescope at Baikal lake (BAIKAL-GVD project).

Abstracts of each of these projects are given below. Each of the projects individually passes through the JINR approval (prolongation) procedures for 2019-2021 years.

## **ТЕМА 03-2-1100-2010/2018 И ЕЕ ПРОДЛЕНИЕ НА 2019-2021 ГОДЫ**

**НАЗВАНИЕ ТЕМЫ: НЕУСКОРИТЕЛЬНАЯ НЕЙТРИННАЯ ФИЗИКА И АСТРОФИЗИКА**

**ШИФР ТЕМЫ: 03-2-1100-2010/2018**

**РУКОВОДИТЕЛИ ТЕМЫ: В.Б. Бруданин, А. Ковалик, Е.А. Якушев**

### **Преамбула:**

Тема “**Неускорительная нейтринная физика и астрофизика**” в ОИЯИ посвящена поиску и исследованию редких процессов с использованием ядерно-физических методов. Тема проводится на базе Научно Экспериментального Отдела Ядерной Спектроскопии и Радиохимии ЛЯП. Этот отдел имеет огромный почти 50-летний опыт прецизионной ядерной спектроскопии с использованием полупроводниковых, сцинтилляционных и других типов детекторов и 30-летний опыт исследования редких процессов в различных подземных лабораториях. Отдел обладает знаниями, персоналом и возможностями для создания установок мирового класса, проведения измерений с ними и получения результатов на мировом уровне. В настоящее время тема состоит из шести основных проектов, реализация которых объединена общими имеющимися ресурсами и научными подходами. В дополнение к шести научным секторам имеются следующие ресурсы, позволяющие проводить реализуемые проекты: лаборатория по производству и ремонту полупроводниковых детекторов; создание и производство сцинтилляционных материалов для детекторов; радиохимический сектор (создание калибровочных радиоактивных источников, очистка материалов от естественной радиоактивности для низкофоновых измерений, и т.д.), механические мастерские, группа компьютерного обеспечения экспериментов, группа масс сепараторов и другие.

Научными задачами, исследуемыми в реализуемых в рамках темы проектах, являются: двойной безнейтринный бета-распад (проекты SuperNEMO и GERDA (G&M)); эксперименты с реакторными антинейтрино: GEMMA-III – поиск магнитного момента нейтрино и когерентного рассеяния нейтрино, DANSS– диагностика реакторов и исследование свойств нейтрино; прямой поиск темной материи (проект EDELWEISS); исследования с глубоководным нейтринным телескопом на озере Байкал (проект BAIKAL-GVD). Аннотации каждого из этих проектов приведены ниже. Каждый из проектов индивидуально проходит через процедуры утверждения (продления) в ОИЯИ на 2019-2021 годы.

## **1) Project SuperNEMO (Investigations of the of $2\beta$ -decay processes of $^{82}\text{Se}$ with the SuperNEMO detector).**

**Project leader: O. Kochetov (kochet@jinr.ru)**

**Project deputy leader: Yu. Shitov**

The SuperNEMO Demonstrator, which is the first module of the SuperNEMO experiment, is located in Modane underground laboratory (France) and search for neutrinoless double beta decay ( $0\nu\beta\beta$ ) of  $^{82}\text{Se}$  in order to unveil the nature of the neutrino. Its detection technique, based on tracking and calorimetry, allows the reconstruction of the full kinematics of detected particles, including individual energies and emission angle. This unique information allows us to investigate the mechanisms of various modes of  $\beta\beta$  decay, reconstruct and fundamentally suppress the background. The creation of the SuperNEMO Demonstrator is the result of 11-year R&D in a number of areas: the creation of optical modules of the calorimeter with record resolution characteristics, a tracker with automated assembly of cells and radon control, improved techniques for creating sources and calibration systems, methodical work on low-background measurements (construction of dedicated setups, the fight against radon, the selection of ultrapure materials).

The goal of the Demonstrator is to validate the technique, achieve the claimed background level, and to reach a sensitivity of the  $0\nu\beta\beta$ - decay half-life of about  $T(0\nu)_{1/2} > 5.9 \times 10^{24}$  yr with “zero background” in the region interest on 7 kg of Se-82 for 2.5 years of measurement. Start of the Demonstrator is planned for next year. It is expected that the main data will be collected in 2019-2021. In the case of a successful work of the Demonstrator, the opportunity will be open for a full-scale SuperNEMO project aimed to measure 100 kg of Se-82 at a sensitivity of  $T(0\nu)_{1/2} > 10^{26}$  years for 5 years of measurement.

The demonstrator has been built with the decisive contribution of JINR to a number of systems: calorimeter, tracker,  $\beta\beta$  sources. The JINR team has 25 years of experience of successful participation in NEMO-2 / NEMO-3 experiments studied  $\beta\beta$  processes in a set of nucleus:  $^{48}\text{Ca}$ ,  $^{82}\text{Se}$ ,  $^{96}\text{Zr}$ ,  $^{100}\text{Mo}$ ,  $^{116}\text{Cd}$ ,  $^{130}\text{Te}$ ,  $^{150}\text{Nd}$ , and in the SuperNEMO R&D program. The required financing of the project is 245 k\$ for 3 years.

### **Publications and talks**

1. R. Arnold et al., Results of the search for neutrinoless double- $\beta$  decay in  $^{100}\text{Mo}$  with the NEMO-3 experiment , Phys. Rev. D 92 (2015) 072011
2. R. Arnold et.al., “Measurement of the double beta-decay half-life and search for the neutrinoless double beta-decay of Ca-48 with NEMO-3 detector”, Phys. Rev. D93 (2016) 112008-1 – 112008-9.
3. A. Jeremie and A. Remoto, on behalf of the SuperNEMO collaboration, The SuperNEMO  $\beta\beta$ -source production, 38th International Conference on High Energy Physics (ICHEP 2016), Chicago, USA, August 3-10, 2016
4. A.S. Barabash et al., Calorimeter development for the SuperNEMO double beta decay experiment, Nucl. Instrum. Meth. A 868 (2017) 98-108
5. A.S. Barabash et al., The BiPo-3 detector for the measurement of ultra low natural radio activities of thin materials, JINST 12 (2017) no.06, P06002
6. F. Mamedov, I. Stekl and K. Smolek, on behalf of the SuperNEMO collaboration, Measurement of the radon diffusion through a nylon foil for different air humidities, Low



- Radioactivity Techniques 2015 (LRT2015), AIP Conference Proceedings 1672, 140007 (2015); <http://dx.doi.org/10.1063/1.4928023>
7. C. Cerna, B. Souleil A<sub>e</sub> and F. Perrot, on behalf of the SuperNEMO collaboration, Radon emanation based material measurement and selection for the SuperNEMO double beta decay experiment, Low Radioactivity Techniques 2015 (LRT2015), AIP Conference Proceedings 1672, 050002 (2015); <http://dx.doi.org/10.1063/1.4927987>
  8. X.R.Liu on behalf of the SuperNEMO collaboration, Radon mitigation strategy and results for the SuperNEMO experiment, XXVIII International Conference on Neutrino Physics and Astrophysics (Neutrino 2016), London, UK, July 4-9, 2016
  9. F. Perrot on behalf of the SuperNEMO collaboration, Strategy of HPGe screening measurements in the SuperNEMO experiment, Low Radioactivity Techniques 2013 (LRT2013), AIP Conference Proceedings 1549, 173 (2013); <http://dx.doi.org/10.1063/1.4818102>
  10. S. Calvez, on behalf of the SuperNEMO collaboration,  $0\nu\beta\beta$ -sensitivity with the SuperNEMO demonstrator, 52nd Rencontres de Moriond EW 2017, La Thuile, Italy, Mars 18-25, 2017
  11. R. Arnold et.al., “Measurement of the double beta-decay half-life and search for the neutrinoless double beta-decay of Cd-116 with the NEMO-3 detector”, Phys. Rev. D95 (2017) 012007-1 – 012007-12.
  12. R. Arnold et.al., “Measurement of the double beta-decay half-life of Nd-150 and a search for neutrinoless double beta-decay processes with the full exposure from the NEMO-3 detector”, Phys. Rev. D94 (2016) 072003.
  13. S. Blot for the NEMO-3&SuperNEMO Collaborations, “Investigating bb decay with NEMO-3 and SuperNEMO experiments”, Journal of Physics: Conference Series 718 (2016).
  14. H. Gomes for the NEMO-3&SuperNEMO Collaborations, “Latest results of NEMO-3 experiment and present status of SuperNEMO”, Nuclear and Particle Physics Proceedings (2016) 1765-1770.
  15. P.Povinec on behalf of the SuperNEMO Collaboration, “SuperNEMO – a new generation of underground experiments for double beta-decay investigations”, The 14th Vienna Conference on Instrumentation 15-16 Feb., 2016.
  16. A.S. Barabash et. al., “Calorimeter development for the SuperNEMO double beta-decay experiment”, NIM A868 (2017) 98-108.
  17. R. Arnold et al. from NEMO-3 Collaboration, “Search for neutrinoless quadrupole- $\beta$  decay of the Nd-150 with the NEMO-3 detector” Phys. Rev. Lett. 119 (2017) 041801.

## 2) Project GERDA “G&M” (Searching for neutrinoless double beta decay of $^{76}\text{Ge}$ )

**Project leader: K.Gusev (Konstantin.Gusev@jinr.ru)**

**Project deputy leaders: A. Lubashevskiy, D. Zinatulina**

The GERDA collaboration searches for  $0\nu\beta\beta$  decay of  $^{76}\text{Ge}$ . The experimental facility is located at the Laboratori Nazionali del Gran Sasso of INFN in Italy. GERDA uses high purity germanium detectors enriched in  $^{76}\text{Ge}$ , which are arranged in strings inside a cryostat filled with  $64\text{ m}^3$  of liquid argon (Fig. 2.1a). The liquid argon (LAR) acts both as cooling and shielding medium. GERDA has been proceeded in two phases.

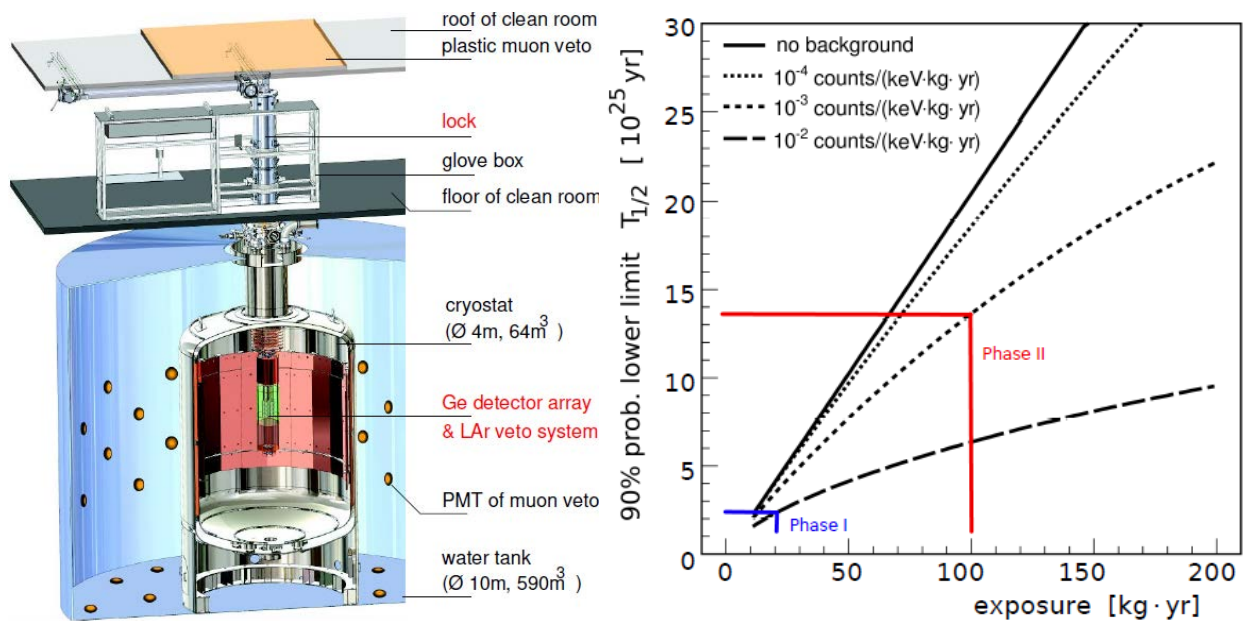

Fig. 2.1. a) Left: GERDA setup. The new Phase II components are marked in red; b) right: estimated sensitivity of the GERDA experiment as a function of exposure for various background indices. The scenarios for GERDA Phase I and II are indicated.

The physics results of Phase I were based on an exposure of  $21.6\text{ kg yr}$ . A background index (BI) of about  $10^{-2}\text{ counts keV}^{-1}\text{ kg}^{-1}\text{ yr}^{-1}$  was achieved, one order of magnitude lower than in the best previous  $0\nu\beta\beta$  decay experiments. No signal was found for  $0\nu\beta\beta$  decay, and a new 90% confidence level (CL) limit of  $T_{1/2}^{0\nu} > 2.1 \times 10^{25}$  years was derived (median sensitivity  $2.4 \times 10^{25}$  years) that strongly disfavored a previous claim of observation. Further Phase I results include an significantly improved half-life for  $2\nu\beta\beta$  decay of  $^{76}\text{Ge}$  and improved limits for Majoron decay modes, as well as  $2\nu\beta\beta$  decays of  $^{76}\text{Ge}$  into excited states of  $^{76}\text{Se}$ .

Phase II of GERDA was aimed to improve the sensitivity on the half-life of  $0\nu\beta\beta$  decay by about one order of magnitude. The half-life sensitivity of  $0\nu\beta\beta$  experiments grows linearly with the exposure, as long as there are no background counts in the ROI close to decay energy. GERDA Phase II is the first background free search for  $0\nu\beta\beta$  decay because of achieved unique background level of  $10^{-3}\text{ counts keV}^{-1}\text{ kg}^{-1}\text{ yr}^{-1}$ . This will allow Phase II to reach the expected sensitivity more  $10^{26}$  years at an exposure of about  $100\text{ kg yr}$  (Fig. 2.1b).

The most important feature of Phase II is the LAr instrumentation surrounding the detector array to readout of scintillation light creating an effective active LAr veto system. It was developed from studies of scintillation light detection in LAr in the low-background test facility LArGe and silicon photomultipliers (SiPMs) coupled to wavelength shifting fibers for increasing light detection efficiency. The usefulness of this approach has been fully proven by the first results obtained with the upgraded GERDA experiment. Started in December 2015, the Phase II physics run reached in June 2016 the exposure of 10.8 kg yr. These accumulated data have been already sufficient to ensure that the projected background level of  $10^{-3}$  counts  $\text{keV}^{-1} \text{kg}^{-1} \text{yr}^{-1}$  has been achieved and, to set in combination with the Phase I data a new lower limit for the  $0\nu\beta\beta$  decay half-life of  $^{76}\text{Ge}$  of  $> 5.3 \times 10^{25}$  years at 90% CL.

### Latest results:

The energy spectrum of Phase II exposure of BEGe detectors collected so far is presented at Fig. 2.2. The blinded region around the  $Q_{\beta\beta}$  is marked by the vertical band. Up to 500 keV the spectrum is mainly consists of  $^{39}\text{Ar}$  events, up to 1.8 MeV by events from  $2\nu\beta\beta$  decays of  $^{76}\text{Ge}$  and Compton scattered events – mostly from the  $^{40}\text{K}$  and  $^{42}\text{K}$   $\gamma$  lines. For the energies higher than 2.62 MeV the events come from  $\alpha$  decays at the  $p^+$  electrode or at the detector groove – generally from  $^{210}\text{Po}$ . The origin of the  $^{40}\text{K}$   $\gamma$  line is an electron capture therefore no energy left in the LAr and only PSD is effective to cut these events. The  $^{42}\text{K}$   $\gamma$  line comes from a  $\beta$  decay and up to 2 MeV are deposited in argon that allows the LAr veto to reject more than 80% of such events. At  $Q_{\beta\beta}$  the spectrum consists of degraded  $\alpha$ ,  $^{42}\text{K}$  decays at the detector surface and Compton scattered  $\gamma$ 's from  $^{214}\text{Bi}$  and  $^{208}\text{Tl}$  decays. The background index for BEGe detectors is equal to  $1.0^{+0.6}_{-0.4} \times 10^{-3}$  counts  $\text{keV}^{-1} \text{kg}^{-1} \text{yr}^{-1}$ . If normalized to the energy resolution and signal efficiency this value is more than factor of five lower compared with any non- $^{76}\text{Ge}$  competitors.

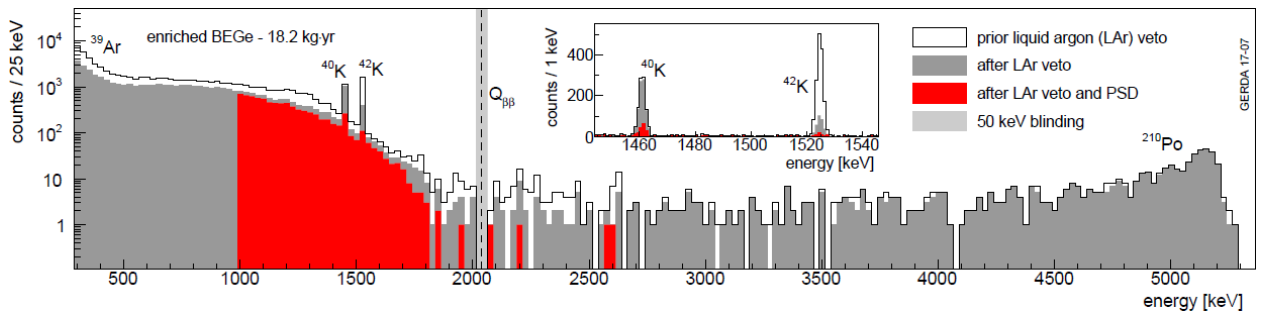

Fig. 2.2. Energy spectra of Phase II BEGe detectors. On the inset the spectrum at the energy of the potassium lines is shown. The vertical grey line band shows the blinded region.

The total exposure used for the last analysis is 23.5 kg yr and 23.2 kg yr for Phase I and Phase II, respectively. No event close to  $Q_{\beta\beta}$  has been found and a 90% C.L. lower limit of  $T_{1/2}^{0\nu} > 8.0 \times 10^{25}$  years has been set for a frequentist analysis, with a median sensitivity of  $5.8 \times 10^{25}$  years. This is the best half-life sensitivity amongst all existing  $0\nu\beta\beta$  experiments. GERDA data taking is ongoing until the designed exposure of 100 kg yr will be achieved. It is planned to be reached in 2019-2020. Then the half-life sensitivity will be well above  $1.0 \times 10^{26}$  years. The sensitivity of GERDA can be additionally improved by reducing the background of the experiment and adding of novel enriched Ge detectors. Such an upgrade of GERDA is going to be performed in 2018-2019. It should include not only the increase of enriched isotope

mass by adding of new enriched detectors but also the replacement of existing active liquid argon veto by improved version.

The GERDA experiment design sensitivity will not allow to get an information about neutrino mass hierarchy. In order to address this issue the new generation experiment LEGEND is being built. It is foreseen at least two phases of the project. The first phase will operate with ~ 200 kg of enriched isotope and the expected sensitivity will be  $10^{27}$  years. The second phase will use 1000 kg and reach  $10^{28}$  years respectively. This project will allow answering the question about neutrino mass hierarchy. It is also very essential, that ultra-low background germanium-based experiments have better  $0\nu\beta\beta$  discovery potential compared with all competitors thanks to the excellent energy resolution of Ge detectors. The first phase of new experiment is going to use the existing GERDA infrastructure at LNGS. Our goal is to start data taking in the first phase of LEGEND in 2021.

The GERDA collaboration consists of more than 100 physicists from 16 institutions of six countries. JINR scientists are playing significant roles in all key parts of the project. DLNP JINR was responsible for design, production, testing and installation of plastic muon veto system. JINR specialists actively participated in the development of LAr instrumentation. Physicists from our institute are strongly involved in the analysis of GERDA data and play the central and leading roles in the core of GERDA experiment – operations with bare germanium detectors. Scientists from JINR plan to actively participate or even take the lead in the key parts of the new generation project LEGEND.

#### **Plan of the Project implementation:**

2018-2019: The upgrade of the GERDA experiment by adding novel enriched detectors and exchanging of the existing liquid argon veto by improved version. Achieving of design sensitivity of  $10^{26}$  years.

2019-2020: Reaching of planned GERDA exposure of 100 kg yr. Preparation of the first phase of next generation experiment LEGEND (procurement of enriched  $^{76}\text{Ge}$ , production and testing of new Ge detectors, R&D of low background materials and electronics).

2020-2021: Completion of the GERDA experiment, publication of results. Modification of GERDA cryostat for LEGEND Phase I. Integration and start data taking of the LEGEND experiment.

#### **Publications and talks:**

1. «The GERDA experiment for the search of  $0\nu\beta\beta$  decay in  $^{76}\text{Ge}$ », Eur. Phys. J. C 73 (2013) 2330.
2. «Results on Neutrinoless Double- $\beta$  Decay of  $^{76}\text{Ge}$  from Phase I of the GERDA Experiment», Phys. Rev. Lett 111 (2013) 122503.
3. «Results on  $\beta\beta$  decay with emission of two neutrinos or Majorons in  $^{76}\text{Ge}$  from GERDA Phase I», Eur. Phys. J. C 75 (2015) 416.
4. « $2\nu\beta\beta$  decay of  $^{76}\text{Ge}$  into excited states with GERDA Phase I», J. Phys. G: Nucl. Part. Phys. 42 (2015) 115201.
5. «The background in the  $0\nu\beta\beta$  experiment GERDA», Eur. Phys. J. C 74 (2014) 2764.
6. «Pulse shape discrimination for GERDA Phase I data», Eur. Phys. J. C 73 (2013) 2583.
7. «Background-free search for neutrinoless double- $\beta$  decay of  $^{76}\text{Ge}$  with GERDA», Nature 544 (2017) 47.

8. «Mitigation of  $^{42}\text{Ar}/^{42}\text{K}$  background for the GERDA Phase II experiment», submitted to Eur. Phys. J. C, preprint: <https://arxiv.org/abs/1708.00226>.
9. «LArGe: active background suppression using argon scintillation for the Gerda  $0\nu\beta\beta$ -experiment», Eur. Phys. J. C 75 (2015) 506.
10. «The performance of the Muon Veto of the GERDA experiment», EPJC 76 (2016) 298.
11. «Status of the GERDA experiment: on the way to Phase II», K.Gusev at TAUP 2015, Torino, Italy
12. «Status of preparations for the Phase II of the GERDA experiment aimed for the  $0\nu\beta\beta$  decay search», A.Lubashevskiy at PATRAS 2015, Zaragoza, Spain.
13. «First results from Phase II of the GERDA experiment», K.Gusev at INPC 2016, Adelaide, Australia.
14. «Neutrinoless double beta decay: First results of GERDA Phase II and the status of other experiments», A.Lubashevskiy at PASCOS 2016, Quy Nhon, Vietnam.
15. «Double Beta Decay Experiments», K.Gusev at ICSSNP 2016, Dubna, Russia.
16. «Double beta decay experiments and neutrino mass investigation: Past, Present and Future», A.Smolnikov at QUARKS 2016, Pushkin, Russia.
17. «From Baksan to worldwide experiments searching for neutrinoless double beta decay», A.Smolnikov at ICSSNP 2017, Nalchik, Russia.
18. «Neutrinoless double beta decay search with the "background free" GERDA experiment», A.Lubashevskiy at ICSSNP 2017, Nalchik, Russia.
19. «GERDA: first background free search for neutrinoless double beta decay», K.Gusev at ICNFP 2017, Crete, Greece.
20. «LEGEND: new opportunity to discover the neutrinoless double beta decay», K.Gusev at ICNFP 2017, Crete, Greece.

### **3) Project GEMMA-III (Investigation of neutrino properties with the low-background germanium spectrometer GEMMA-III)**

**Project leader: V. Brudanin (brudanin@jinr.ru)**

**Project deputy leaders: A. Lubashevskiy, E. Yakushev**

The GEMMA-III project is aimed to investigate fundamental properties of neutrino at close vicinity of the reactor core of Kalinin Nuclear Power Plant (KNPP). The GEMMA collaboration consists of scientists from JINR (Dubna), ITEP (Moscow) and MEPhI (Moscow).

Measurement of the neutrino properties is a very important task for particle physics, astrophysics and cosmology. Being one of the most abundant particle in the Universe its detection is very challenging due to a very weak interaction with matter. To investigate its properties, it is required to have a very strong source of the neutrinos and apply various methods for the suppression of background events. A magnetic moment is the fundamental parameter of the neutrino and its investigation may lead to results beyond the standard concepts of elementary particle physics and astrophysics. The Minimally Extended Standard Model predicts a very small magnetic moment value for the massive neutrino ( $\mu_\nu < 10^{-19} \mu_B$ ) that cannot be observed in a present experiment. However, there are a number of theory extensions beyond the Standard Model where Magnetic Moment of Neutrino (MMN) could be at the level of  $10^{-(10-12)} \mu_B$  for Majorana neutrino. The observation of MMN value higher than  $10^{-14} \mu_B$  would be an evidence of New Physics and would give an evidence that neutrino is a Majorana particle. Coherent Elastic Neutrino-Nucleus Scattering (CENNS) is a process predicted by the Standard Model, but has not been observed yet for the reactor neutrino. The detection of this process would be an important test of the Standard Model. Such observations can also help for search for non-standard neutrino interactions, sterile neutrinos and other investigations. Due to a low cross section and a tiny energy deposition, it is not easy to observe such a process.

The GEMMA-III is a new experiment under construction at the Kalinin Nuclear Power Plant for detection of these processes. This experiment is an evolution of our previous projects GEMMA and vGEN. The first phase of the project (GEMMA-I) set up the world best upper limit for MMN of  $< 2.9 \cdot 10^{-11} \mu_B$  (90% CL). The measurements were performed with 1.5 kg High Purity germanium detector which has the effective energy threshold of about 2.8 keV. Using passive and active methods of the background suppression in GEMMA-I experiment it was possible to achieve background level at the low energy region of about  $2.5 \text{ cts}/(\text{keV} \cdot \text{kg} \cdot \text{day})^{-1}$ .

The GEMMA-III project will move the investigations of the neutrino properties on a new level of sensitivity. The experimental setup is located at about 10 m from the 3 GW<sub>th</sub> reactor core of KNPP. This allows to operate a neutrino flux greater than  $5 \cdot 10^{13}$  per cm<sup>2</sup> per second. The available place for the measurement is located just under the reactor, which provides about 50 m w.e. shielding from cosmic rays. The scheme of the reactor is shown in Fig. 3.1, left.

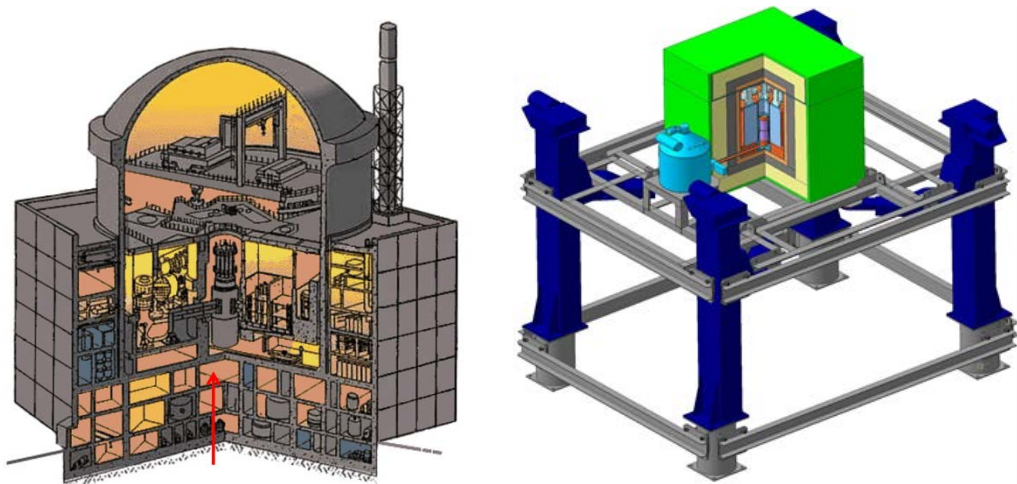

Fig. 3.1. Left: the scheme of the reactor unit #3 at KNPP. Arrow indicates the room where experimental setup is being constructed. Right: the scheme of the spectrometer placed on the lifting mechanism.

A special lifting mechanism allows to move the spectrometer away from the reactor core, suppressing main systematic errors caused by possible long-term instability and neutrino flux (Fig. 3.1, right). It gives us an opportunity to vary on-line the antineutrino flux significantly and reduce uncertainties of the background.

Currently investigations were performed within  $\nu$ GEN project. Four low background HPGe detectors with modified p+ contact produced in cooperation between JINR (Dubna) and BSI (Riga) are used to detect CENNS. The total mass of the detectors is about 1.6 kg. The detectors are placed inside a low background U-type cryostat (see Fig. 3.2).

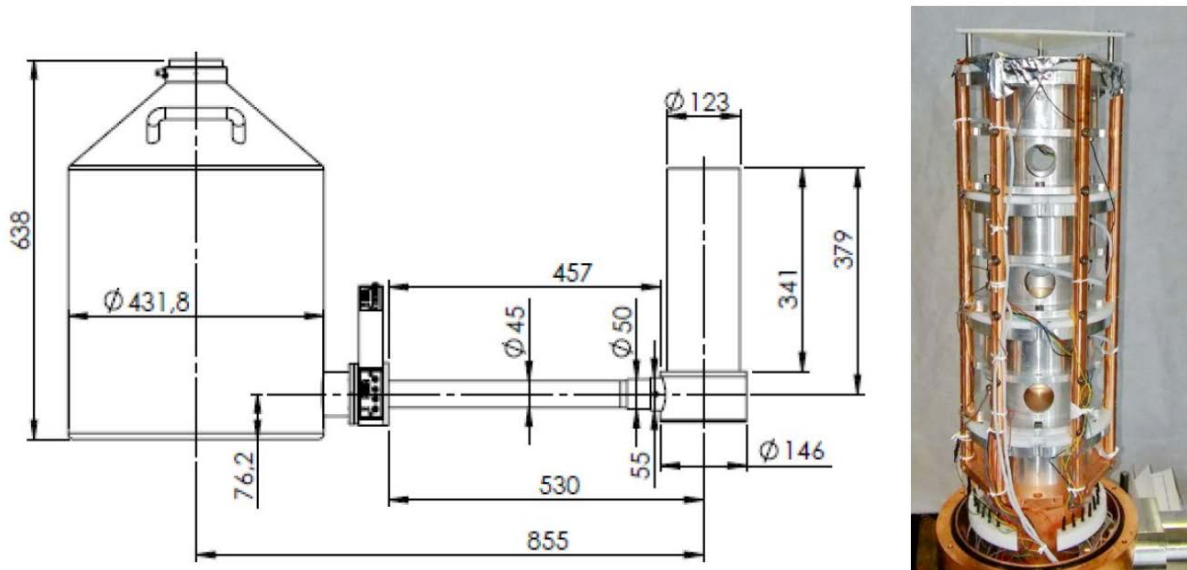

Fig. 3.2. Left: general scheme of the  $\nu$ GEN cryostat for 4 HPGe detectors. Right: photo of the internal part that includes holders for 4 HPGe detectors.

The  $\nu$ GEN HPGe detectors were tested at the LSM underground laboratory in a low-background passive shield made from copper and lead. For the energy region from 100 to



600 keV the background index was found to be  $0.66 \pm 0.03$  cpd/(kg·keV). Fig. 3.3 demonstrates the experimental low energy spectrum for one of the detectors.

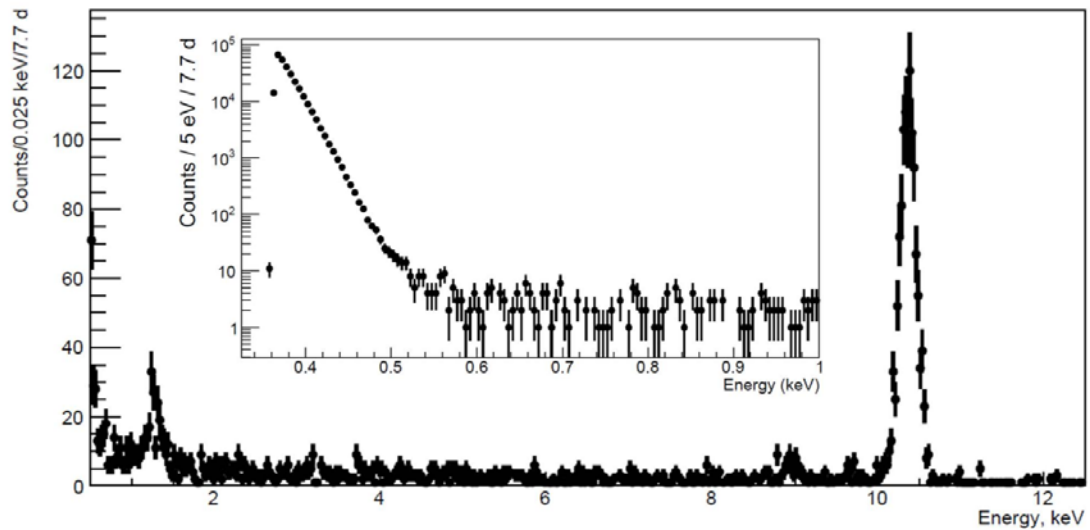

Fig. 3.3. The low energy spectrum for detector N4. The energy scale was calibrated with clearly detected 1.3 keV and 10.37 keV cosmogenic lines. The low energy part of the spectrum is shown as the insert with the logarithmic scale.

Simplified acquisition system was used during the tests. The main conclusion of the performed tests is that achieved energy thresholds and preliminary values of the experimental background are adequate in order to start further commissioning of the setup with proper acquisition chain and the veto systems at the KNPP experimental site.

After radiopurity tests at LSM, detectors were moved to JINR (Dubna). A new acquisition system has been installed. Signal from germanium detector currently are taken by means of real time ADC. The best energy resolution achieved with a pulse generator is about 170 eV (FWHM). The noise events are being suppressed by comparing signals reconstructed with different shaping times of amplifiers. Periodical noise is suppressed by the time cut. Calibration with a pulse generator demonstrates that after applying all cuts it is still possible to detect events with energy below 350 eV with an efficiency of about 70%. This should be sufficient for detection of CENNS. After these tests the spectrometer was moved to the experimental room at KNPP. Currently we are constructing a passive shielding around of vGEN spectrometer. The data taking for the CENNS is going to start this year.

At the same time, we are planning to increase the sensitivity of the experiment by using detectors with a higher masses and lower threshold. Such an upgrade is called GEMMA-III project. Recent development on a detector production allows us to produce detectors with significantly higher resolution than it was achieved before. New detectors produced by CANBERRA have resolution below 80 eV (FWHM) with masses of a few kg. It is possible to work with an energy threshold below 200 eV with them. This energy threshold increase greatly the number of events from neutrino scattering and increase sensitivity of the experimental setup.

Using all infrastructure developed for vGEN experiment we are going to swap existing vGEN cryostat by a newly produced CANBERRA detectors. The first 1 kg detector after successful testing at LSM will arrive to JINR in the beginning of 2018. After its arrival we are planning to move it to KNPP and replace vGEN spectrometer. Altogether, we are planning to use four detectors with a total detector mass of about 5.5 kg. The detectors should be ready in the



end of 2018. This allows to detect of about 190 events from CENNS per day. The sensitivity to magnetic moment of the neutrino would be about  $9 \cdot 10^{-12} \mu_B$  after several years of data taking.

Thus, the project GEMMA-III is the continuation of predecessor projects GEMMA and vGEN. By previous steps it was demonstrated that our group is able to perform modern investigations with HPGe detectors achieving very low background level on a shallow depth. The limit on a magnetic moment of the neutrino obtained in the GEMMA-I experiment is the best in the world so far beyond the terrestrial experiments. We are going to continue our studies and improve our knowledge on the neutrino parameters.

### **Publications and talks**

1. Beda A. G. et al. // *Advances in High Energy Physics* V.2012 (2012), Article ID 350150, 12 pages doi:10.1155/2012/350150
2. Alekseev I. et. al. // arXiv:1305.3350, 2013
3. A. Beda et al. GEMMA experiment: the results of neutrino magnetic moment search, *Physics of Particles and Nuclei Letters*, 2013, V.10, №2, pp.139-143
4. V. Belov et al., "The vGeN experiment at the Kalinin Nuclear Power Plant", 2015 JINST 10 P12011.
5. D. Medvedev, The International Workshop on Non-Accelerator New Physics (NANPino-2013), Valday, Russia, 2013 2. D. Medvedev, Sixteenth Lomonosov Conference on Elementary Particle Physics, Moscow State University, Moscow, Russia, 2013 3. D. Medvedev, Wilhelm and Else Heraeus-Seminar Exploring the neutrino sky and fundamental particle physics on the Megaton scale, Bad Honnef, Germany, 2013 4. D. Medvedev, Wilhelm and Else Heraeus-Seminar Exploring the neutrino sky and fundamental particle physics on the Megaton scale (poster), Bad Honnef, Germany, 2013
6. V. Egorov, Symposium on JINR-SA collaboration, South Africa, 2012 6. D. Medvedev, JINR neutrino program, Dubna, Russia, 2013 7. D. Medvedev, The International Workshop on Prospects of Particle Physics: "Neutrino Physics and Astrophysics", JINR, INR, Valdai, Russia, 2014
7. D. Medvedev, AYSS 2016, Alushta, Russia, 2016
8. V.Belov, A.Kuznetsov, D. Medvedev, ISAAP, Milan, Italy, 2016
9. V.Belov, A.Kuznetsov, D. Medvedev, ISAAP, Arenzano, Italy, 2017 11. A. Lubashevskiy, ICSSNP 2017, Nalchik, Russia, 2017 12. D. Medvedev, ICSSNP 2017, Nalchik, Russia, 2017
10. A. Lubashevskiy, ISSP 2017, Erice, Italy, 2017

#### **4) Project DANSS (Detector of the reactor Anti-Neutrino based on Solid state plastic Scintillator)**

**Project leader: V. Egorov (egorov@jinr.ru)**

**Project deputy leader: V. Brudanin**

Following the Project, a relatively compact neutrino detector **DANSS** with 1 m<sup>3</sup> sensitive volume has been developed and created. The detector does not contain caustic, flammable or other dangerous liquids and therefore does not meet any restrictions against location close to industrial power reactors. The DANSS spectrometer is mounted at the fourth unit of Kalinin Nuclear Power Plant (KNPP) in the room #A336 which is located just below the core of the WWER1000 reactor with 3100 MW thermal power. Due to such position, there are more than 104 IBD neutrino interactions per day in the detector body. On the other hand, the detector is shielded against cosmic rays with a big amount of hydrogen-containing materials located above it. Together with high segmentation of plastic scintillator, as well as combined passive and active shielding, all these factors ensure good background suppression down to few percent and provide about 5000 useful events detected per day. A lifting gear allows moving *on-line*, varying the distance to the reactor core from 10.7 to 12.7 m. Due to this feature, the **DANSS** detector is used now to search for short-range neutrino oscillation to a sterile state. It is expected that we get the final answer about existence of so-called “reactor anomaly” in 2018.

In the next 2019–2021 period it is planned to widen the range of the DANSS sensitivity for the oscillation parameters (by higher statistics and, mostly – by detailed investigation of systematic factors). The second goal is precise measurement of the neutrino energy spectrum as a function of time during 2-3 campaigns. These data would produce a basis of reactor neutrino monitoring (actual power and fuel composition). The price of the above activity is estimated as \$30,000 per year and covers permanent presence of two JINR physicists at KNPP (Udomlya, Tver region, 285 km from Dubna), maintenance and repair of the spectrometer equipment, assistance of local KNPP personnel and rent of an office in Udomlya.

The next point of our proposal is the JINR limited contribution (within \$170,000) to a common (**JINR + NEOS + Neutrino4**) creation of a new neutrino detector near the research SM3 reactor at NIIAR (Dimitrovgrad, Ulyanovsk region) which could measure neutrino spectrum at 5-18 m distances, thus expanding the oscillation parameters ROI.

In addition, it is planned to develop and create (taking into account accumulated experience) two new neutrino detectors **S3** (*S-cube*) based on another scintillator element. Being smaller, simpler and cheaper than **DANSS**, they would have better energy resolution and be able to detect about 300-400 IBD events per day, thus providing reliable reactor monitoring. The price of one of two such **S3** detectors is estimated as ~\$270,000 (the second one will be created by ÚTEF ČVUT in Prague and installed then at the Temelin NPP, Czechia).

## 5) Project EDELWEISS-LT (Direct low-mass WIMP searches with HPGe Semiconductor Bolometers)

Project leader: E. Yakushev (yakushev@jinr.ru)

Project deputy leader: S. Rozov

### Introduction and general description of the EDELWEISS setup:

The EDELWEISS program searches for direct evidence of Dark Matter (DM) WIMPs from the Milky Way galaxy through their scattering of Ge nuclei within cryogenic Ge crystals. The EDELWEISS detectors are cryogenic (work temperature is about 20 mK) Ge bolometers with simultaneous measurement of phonon and ionization signals. The comparison of the two signals provides event-by-event discrimination between nuclear recoils (induced by WIMP and also by neutron scattering) and electrons. EDELWEISS collaboration demonstrated that the main background limiting the sensitivity of the Ge based (and other) experiments arises from the inability to reject events occurring close to the surface of the detector, for which a deficient charge collection can mimic the ionization yield of nuclear recoils. Therefore detectors for EDELWEISS were developed with an innovative interleaved electrode design, able to discriminate against events occurring within 1 mm from the detector surface. The developed technology shows unprecedented and world-leading improvement of surface background suppression.

The EDELWEISS experiment is set in the Laboratoire Souterrain de Modane (LSM), under 1800 m of rock overburden ( $\sim 4700$  mwe). The heart of the EDELWEISS experiment is  $^3\text{He}$ - $^4\text{He}$  dilution cryostat with HPGe detectors-bollometers. The EDELWEISS shielding concept shown on the Fig. 5.1 includes the surrounding of detectors by 20 cm of Pb (include internal layer from archaeological roman lead), 50 cm of polyethylene and active  $\mu$ -veto. The cryostat environment is supplied with radon-free air.

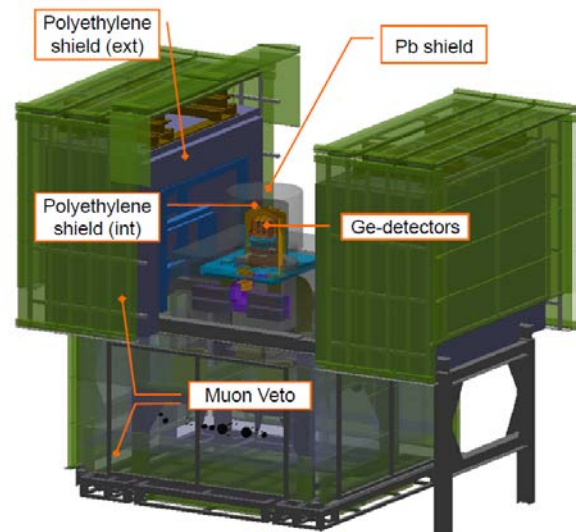

Fig. 5.1, Scheme of EDELWEISS setup.

The setup with all shielding is located in an air-tight and pressurized clean room of class 1000. The radioactivity levels of all construction materials were tested prior to their use.

In the present time there is an increasing gain of interest for the search of low-mass WIMPs arising on the one hand from non evidence yet for SUSY at the LHC and on the other hand from new theoretical approaches favoring lighter candidates. As an example, asymmetric DM models linking the relic density to the baryon asymmetry predict DM particles of a few  $\text{GeV}/c^2$ . Thus main objective of the EDELWEISS is now shifted to the low-mass WIMPs region ( $10 \text{ GeV}/c^2$  and below) which could be investigated in the experiment thanks to advantage of 100 eV energy resolution reachable with HPGe bolometers via the Neganov-Luke effect of internal amplification of the heat signal.

## Current phase experimental results:

At the current stage of the experiment the most important from result is connected with investigation of low-mass WIMPs region from 4 to 30  $\text{GeV}/c^2$  (Fig. 5.2). For the extreme case for WIMPs with  $m_\chi = 4 \text{ GeV}/c^2$  the 90 % C.L. exclusion limit set currently by EDELWEISS is  $1.6 \times 10^{-39} \text{ cm}^2$ . Therefore, positive results reported by some others experiments were directly verified. It is important that the achieved by EDELWEISS-III sensitivity completely covered region of positive CoGeNT results obtained on the same nuclear (Ge).

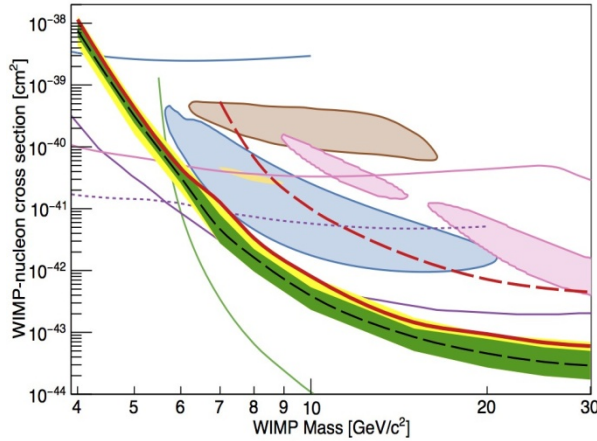

Fig. 5.2. Red curve: 90% CL limit on the spin-independent WIMP-nucleon cross-section obtained by EDELWEISS. The green (resp. yellow) band represents the expected  $1\sigma$  (resp.  $2\sigma$ ) sensitivity region in the absence of a signal. The yellow, blue, pink and brown contours are respectively from CoGeNT, CDMS-Si, CRESST-II and DAMA. We also represent other limits by EDELWEISS-II (dashed red), LUX (green), DAMIC (blue), CRESST (pink), CDMSLite (dashed violet) and SuperCDMS (violet).

## EDELWEISS-LT

During the EDELWEISS-LT phase of the project measurements with several low threshold bolometers using Neganov-Luke effect of internal amplification of the heat signal will be performed. That will target light WIMP - nucleon cross section on the level of better of  $10^{-41} \text{ cm}^2$  competitive with best results of other experiments. The EDELWEISS-LT will be based on the same experimental infrastructure (shield, dilution cryosystem and low background cryostat, acquisition system) that is currently available in the LSM underground laboratory.

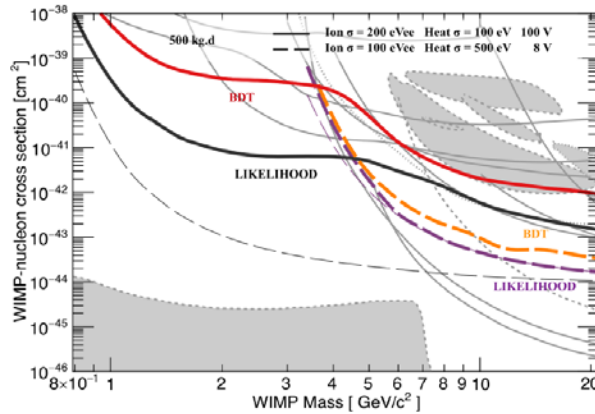

Fig. 5.3. EDELWEISS-LT projected sensitivities with current background. Exclusion limits are derived from BDT and profile likelihood approaches and for the two extreme bias voltage conditions (8V, 100V). Below masses of  $5 \text{ GeV}/c^2$ , the best sensitivity will be obtained by lowering the thresholds, with the Neganov boost corresponding to a bias voltage of 100V. Official EDELWEISS-LT low-mass projected sensitivity is given by the black solid line exclusion limit.

Fig. 5.3 presents the two major scenarios for near future low-mass WIMP search with EDELWEISS-LT, considering efforts have been put on the R&D, aiming at improving at least one of the energy resolutions, either for heat or for ionization signals. Sensitivities have been computed with both boosted decision tree (BDT) and likelihood methods for a total exposure of 500 kg d with our current background levels and setup at the LSM. Improving ionization resolution could be done through the implementation of High Electron Mobility Transistors (HEMT) to replace Junction Field Effect Transistors (JFET) used for charge measurements on

the Al electrodes collecting electron-hole pairs. Concerning heat resolution improvement, dedicated R&D is also in progress on baseline performance with the achievable objective of reaching  $\sigma_{\text{Eheat}} = 100$  eV: a coherent thermal model has been constructed by EDELWEISS and is used to extract relevant parameters of the heat signal in order to build new thermal sensors which would provide the expected heat energy resolution improvement. It could lead to nuclear recoil energy thresholds ranging from 400 to 100 eV<sub>nr</sub>, depending on the applied bias voltage across the crystal.

Further ahead the requirements to the EDELWEISS-LT will to approach the neutrino floor, which corresponds to the coherent scattering of solar  $^8\text{B}$  neutrinos. Fig. 5.4 shows sensitivity projections derived from the likelihood analysis for a large exposure of 50000 kgd and resolutions of both heat and ionization channels at 100 eV. Limits are computed for both 8 V and 100 V bias voltages and plotted in purple and black, respectively. Solid lines of Fig. 4.4 correspond to the expected limits achievable considering the current EDELWEISS background budget, with the exception of heat-only events, which are supposed to be completely suppressed. Thick dashed lines (dot dashed lines) are obtained assuming not only no more heat-only events (a reduction of heat-only events by a factor 100), but also no more neutrons and a reduction of the Compton background by a factor 10. The background-free sensitivity is shown in thin dashed lines.

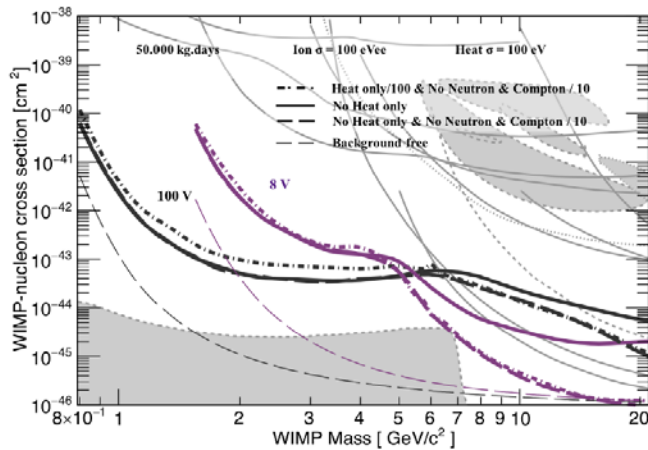

Fig. 5.4. Projected sensitivities for a large exposure of 50000 kgd with strongly improved background levels and R&D upgrade performance achieved. Limits are computed using a likelihood analysis at 8 V (purple) and 100 V (black) assuming a suppression of the heat-only background (solid line), and no more neutron background associated with a reduction of the Compton background by a factor 10 (thick dashed line). The background-free sensitivity is shown in thin dashed lines

### Dubna group responsibilities

Dubna team of the EDELWEISS project is formed on the base of Department of Nuclear Spectroscopy, DZLNP. This department has huge almost 50-years experience in high-precision nuclear spectroscopy using semiconductor and scintillator detectors in general and 30-years experience of rare process study in underground environment.

JINR team of the project is expected to contribute to: 1) Development of new low threshold Ge detectors; Assembly and commissioning; 2) Development of methods for underground site low background measurements; 3) Data taking (this includes daily routine procedures, as well as regular and special calibration runs); 4) Low background study and development of methods of neutron and radon detection; 5) Detector simulations and data analysis; Publication of results.

Main participation of JINR in the EDELWEISS-LT projects will be in providing of expertise on background connected problems as well conducting of measurements of backgrounds and selection of radio-pure materials (which are needed for new detectors: supports, cables, electronic circuits, etc). We will continue study of neutrons and radon at the deep

underground site. Our activity in the experiment will also includes WIMP data analysis and MC of detectors. JINR group will also perform other tasks it is responsible for: as for example the calibration of EDELWEISS detectors with radioactive neutron and gamma sources.

The Dubna group is also responsible for R&D, installation and running of point contact detectors in frame of the EDELWEISS collaboration. This work is extremely important for JINR since provides base and infrastructure for development and test of low radioactive low energy threshold setups for neutrino experiments at Kalinin NPP. The EDELWEISS-I shield is provided for the point contact detector tests. In the same time other facilities as clean room, radon-free air, etc are also available and used. In 2018 JINR group will start of tests of unique point contact detectors with masses from 1 to 1.5 kg and with energy thresholds at about 200 eV.

### **Publications**

1. Q Arnaud, et al (EDELWEISS collaboration) Optimizing EDELWEISS detectors for low-mass WIMP searches, 2017, arXiv preprint arXiv:1707.04308, submitted to Phys. Rev. D
2. E Armengaud, et al (EDELWEISS collaboration), Measurement of the cosmogenic activation of germanium detectors in EDELWEISS-III, *Astroparticle Physics*, 91, 2017, 51-64
3. E Armengaud, et al (EDELWEISS collaboration) Performance of the EDELWEISS-III experiment for direct dark matter searches, *Journal of Instrumentation*, 12, 08, P08010, 2017, arXiv preprint arXiv:1706.01070
4. L Hehn, et al (EDELWEISS collaboration) Improved EDELWEISS-III sensitivity for low-mass WIMPs using a profile likelihood approach, 2016, *The European Physical Journal C* 76 (10), 548
5. E Armengaud, et al (EDELWEISS collaboration) Constraints on low-mass WIMPs from the EDELWEISS-III dark matter search, 2016, *Journal of Cosmology and Astroparticle Physics* 2016 (05), 019
6. AV Rakhimov, et al, Neutron activation analysis of polyethylene from neutron shield of EDELWEISS experiment, *Radiochimica Acta* 103 (9), 673-678, 2015 G Angloher et al, EURECA conceptual design report, *Physics of the Dark Universe*, 3, 41-74, 2014
- B Schmidt et al. Muon-induced background in the EDELWEISS dark matter search. 2013, *Astroparticle Physics* 44, 28-39.
7. E. Armengaud et al. (EDELWEISS collaboration) Axion searches with the EDELWEISS-II experiment. In: *JCAP* 1311 (2013), p. 067. arXiv: 1307.1488 [astro-ph.CO];
8. E Armengaud, et al (EDELWEISS collaboration) Background studies for the EDELWEISS dark matter experiment, *Astroparticle Physics* 47, 1-9, 2012
9. E Armengaud, et al (EDELWEISS collaboration) Search for low-mass WIMPs with EDELWEISS-II heat-and-ionization detectors, *Physical Review D* 86 (5), 051701, 2012

## 6) BAIKAL-GVD (Deep underwater muon and neutrino detector on Lake Baikal)

**Project leader: I. Belolaptikov (belolap@nu.jinr.ru)**

The construction of the Baikal-GVD neutrino telescope is motivated by its discovery potential in astrophysics, cosmology and particle physics. Its primary goal is the detailed study the diffuse flux of high-energy cosmic neutrinos and the search for their sources. It will also search for dark matter candidates (WIMPs), for neutrinos from the decay of super heavy particles, for magnetic monopoles and other exotic particles. The high angular resolution of GVD for track-like or cascade-like events ( $\sim 0.25\text{-}0.5^\circ$  for muon tracks and  $\sim 2\text{-}3^\circ$  for cascades, respectively) provides a high capability for identifying point-like cosmic-ray accelerators. It will also be a platform for environmental studies in Lake Baikal.

The concept of BAIKAL-GVD is based on a number of evident requirements to the design and architecture of the recording system of the array: the utmost use of the advantages of array deployment from the ice cover of Lake Baikal, the extendibility of the facility and provision of its effective operation even in the first stage of deployment, and the possibility of implementing different versions of arrangement and spatial distribution of light sensors within the same measuring system.

With all above requirements taken into account, the following conceptual design of BAIKAL-GVD has been developed. The Data Acquisition System of BAIKAL-GVD is formed from three basic building blocks: optical modules (OM), sections of OMs and clusters of strings. The OM consists of a photomultiplier tube with large hemispherical photocathode and attendant electronics, which are placed in pressure-resistant glass sphere.

The detector will utilize the deep water of Lake Baikal instrumented with OMs, which record the Cherenkov radiation from secondary particles produced in interactions of high-energy neutrinos inside or near the instrumented volume. The Infrastructure will consist of a network of autonomous subdetectors - so-called clusters – each of them with 288 OMs arranged at eight vertical strings attached to the lake floor. The coordinates of the optical modules are determined using an acoustic positioning system. Acoustic positioning system of the cluster comprises 32 acoustic modems (AM). The clusters are connected to shore via a network of cables for electrical power and high-bandwidth data communication. The large cubic-kilometer scale detection volume, combined with high angular and energy resolutions and moderate background conditions in fresh lake water allows for efficient study of cosmic neutrinos, muons from charged cosmic rays and exotic particles. It is also an attractive platform for environmental studies.

During the Design Study (2008–2010) and the Preparatory Phase (2011–2015), design, production and comprehensive in-situ tests of all elements and systems of the future detector have been performed. The Preparatory phase was concluded in 2015 with the deployment of a demonstration cluster "Dubna" comprising 192 OMs. The construction of the first phase of Baikal GVD (GVD-I) was started in 2016 by deployment of the first cluster in its baseline configuration (see fig. 6.1).







### Timeline for GVD Phase-1

2017	2018	2019	2020
2 clusters (deployed)	4 clusters	6 clusters	8 clusters

GVD Phase 2: extension to 14 (possibly technologically upgraded) Timeline Phase-2:

2021	2022	2023
10 clusters	12 clusters	14 clusters

A further extension of Phase 2 to more 14 clusters will depend on the worldwide physics situation in the 2020s, on additional funding from new partners, and last but not least on the performance and physics output of the BAIKAL-GVD detector.

### Contribution of JINR Members

JINR Members are playing significant roles in all key parts of the BAIKAL experiment:

- Assembly and test of OMs and strings
- Participation in winter deployment campaigns
- Access and security service.
- Data archive processing and analysis.
- Detector calibration and mass processing of data.
- Remote control and monitoring systems of detector
- Simulation software and MK production.
- On-line software
- Development of new methods of event selection and reconstruction.
- Data analysis with respect to high-energy neutrinos and neutrinos from dark matter annihilation.

### Publication and talks

1. Status of the Baikal-GVD Project: First Cluster Dubna, A.D. Avrorin et al.. 2017. 4 pp. DOI: 10.1142/9789813224568\_0025 Conference: C15-08-20, p.160-163 Proceedings
2. Acoustic Search for High Energy Neutrinos in Lake Baikal: Status and Perspectives, N.M. Budnev (Irkutsk State U.) et al.. 2017. 7 pp. Published in EPJ Web Conf. 135 (2017) 06004 DOI: 10.1051/epjconf/201713506004 Conference: C16-06-07 Proceedings
3. Dark matter constraints from an observation of dSphs and the LMC with the Baikal NT200 A.D. Avrorin (Moscow, INR) et al.. Dec 12, 2016. 15 pp. Published in JETP Vol. 152 (7) (2017) e-Print: arXiv:1612.03836 [astro-ph.HE]
4. The optical module of Baikal-GVD A.D. Avrorin (Moscow, INR) et al.. 2016. 10 pp. Published in Phys.Part.Nucl.Lett. 13 (2016) no.6, 737-746 DOI: 10.1134/S1547477116060029
5. Data acquisition system for the Baikal-GVD neutrino telescope, A.V. Avrorin (Moscow, INR) et al.. 2016. 5 pp. Published in Phys.Part.Nucl. 47 (2016) no.6, 933-937 DOI: 10.1134/S1063779616060058, Conference: C15-02-01 Proceedings

6. Neutrino signal at Baikal from dark matter in the Galactic Center, A.D. Avrorin (Moscow, INR) et al.. 2016. 7 pp. Published in *Phys.Part.Nucl.* 47 (2016) no.6, 926-932 DOI: 10.1134/S1063779616060046 Conference: C15-02-01 Proceedings
7. The optical detection unit for Baikal-GVD neutrino telescope, A.D. Avrorin (Moscow, INR) et al.. 2016. 6 pp. Published in *EPJ Web Conf.* 121 (2016) 05008, DOI: 10.1051/epjconf/201612105008, Conference: C14-09-30 Proceedings
8. Status and perspectives of the BAIKAL-GVD project, A.D. Avrorin (Moscow, INR) et al.. 2016. 6 pp. Published in *EPJ Web Conf.* 121 (2016) 05003 DOI: 10.1051/epjconf/201612105003 Conference: C14-09-30 Proceedings
9. Status of the early construction phase of Baikal-GVD, A.D. Avrorin (Moscow, INR) et al.. 2016. 7 pp. Published in *Nucl.Part.Phys.Proc.* 273-275 (2016) 314-320 DOI: 10.1016/j.nuclphysbps.2015.09.044 Conference: C14-07-02 Proceedings
10. Baikal-GVD: Results, status and plans, A.D. Avrorin (Moscow, INR) et al.. 2016. 6 pp. Published in *EPJ Web Conf.* 116 (2016) 11005 DOI: 10.1051/epjconf/201611611005 Conference: C15-09-14.6 Proceedings
11. LED based calibration systems of the Baikal-GVD neutrino telescope, A.D. Avrorin (Moscow, INR) et al.. 2016. 5 pp. Published in *EPJ Web Conf.* 116 (2016) 06005 DOI: 10.1051/epjconf/201611606005 Conference: C15-09-14.6 Proceedings
12. The data acquisition system for Baikal-GVD, A.D. Avrorin (Moscow, INR) et al.. 2016. 4 pp. Published in *EPJ Web Conf.* 116 (2016) 05004 DOI: 10.1051/epjconf/201611605004 Conference: C15-09-14.6 Proceedings
13. The optical module of Baikal-GVD, A.D. Avrorin (Moscow, INR) et al.. 2016. 5 pp. Published in *EPJ Web Conf.* 116 (2016) 01003 DOI: 10.1051/epjconf/201611601003 Conference: C15-09-14.6 Proceedings
14. A search for neutrino signal from dark matter annihilation in the center of the Milky Way with Baikal NT200, BAIKAL Collaboration (A.D. Avrorin (Moscow, INR) et al.). Dec 3, 2015. 9 pp. Published in *Astropart.Phys.* 81 (2016) 12-20 DOI: 10.1016/j.astropartphys.2016.04.004 e-Print: arXiv:1512.01198 [astro-ph.HE]
15. Baikal-GVD: first cluster Dubna, A.D. Avrorin (Moscow, INR) et al.. Nov 7, 2015. 6 pp. Published in *PoS EPS-HEP2015* (2015) 418 Conference: C15-07-22 Proceedings e-Print: arXiv:1511.02324 [physics.ins-det]
16. Status of the Baikal-GVD Project, BAIKAL-GVD Collaboration (A.D. Avrorin (Moscow, INR) et al.). 2015. 4 pp. DOI: 10.1142/9789814663618\_0019 Conference: C13-08-22, p.98-101
17. Status and recent results of the BAIKAL-GVD project, A.D. Avrorin (Moscow, INR) et al.. 2015. 11 pp. Published in *Phys.Part.Nucl.* 46 (2015) no.2, 211-221 DOI: 10.1134/S1063779615020033 Conference: C14-01-26 Proceedings
18. Sensitivity of the Baikal-GVD neutrino telescope to neutrino emission toward the center of the galactic dark matter halo, A.D. Avrorin (Moscow, INR) et al.. Dec 11, 2014. 6 pp. Published in *JETP Lett.* 101 (2015) no.5, 289-294 DOI: 10.1134/S0021364015050021, e-Print: arXiv:1412.3672 [astro-ph.HE]
19. Search for neutrino emission from relic dark matter in the Sun with the Baikal NT200 detector, Baikal Collaboration (A.D. Avrorin (Moscow, INR) et al.). May 14, 2014. 9 pp. Published in *Astropart.Phys.* 62 (2015) 12-20 DOI: 10.1016/j.astropartphys.2014.07.006 e-Print: arXiv:1405.3551 [astro-ph.HE]