

МОДЕРНИЗАЦИЯ ДЕТЕКТОРА АТЛАС

Коллаборация АТЛАС

Тема 02-0-1081-2009/2019

СПИСОК АВТОРОВ  
(прилагается)

РУКОВОДИТЕЛЬ ПРОЕКТА – ЧЕПЛАКОВ А.П. (ЛФВЭ)

ЗАМЕСТИТЕЛЬ РУКОВОДИТЕЛЯ ПРОЕКТА – А. ГОНГАДЗЕ (ЛЯП)

ДАТА ПРЕДСТАВЛЕНИЯ ПРОЕКТА В НОО \_\_\_\_\_

ДАТА НТС ЛАБОРАТОРИИ - 14.11.2019 НОМЕР ДОКУМЕНТА \_\_\_\_\_

ДАТА НАЧАЛА ПРОЕКТА - 01.01.2021

(ДЛЯ ПРОДЛЕНИЙ — ДАТА ПЕРВОГО УТВЕРЖДЕНИЯ ПРОЕКТА) 29.01.2013

**Upgrade of the ATLAS Detector**

ATLAS Collaboration

Theme 02-0-1081-2009/2019

LIST OF AUTHORS IS APPENDED  
(appended)

Project leader - Alexander CHEPLAKOV (VBLHEP)

Project leader deputy - Alexi GONGADZE (DLNP)

DATE OF SUBMISSION OF PROPOSAL OF PROJECT TO SOD \_\_\_\_\_

DATE OF THE LABORATORY STC - 14.11.2019 DOCUMENT NUMBER \_\_\_\_\_

STARTING DATE OF PROJECT - 01.01.2021

(FOR EXTENSION OF PROJECT — DATE OF ITS FIRST APPROVAL) - 29.01.2013

# List of the project participants (including FTE)

## Muon spectrometer

A. Gongadze-1, G. Chelkov-1 (DLNP), N. Zimine-1 (VBLHEP) - coordinators  
M. Balykina-1, B. Buadze-1, Z. Chubinidze-1, E. Cherepanova-0.3, N. Doroshkevych-1, I. Gongadze-1, L. Gongadze -1, M. Gostkin-0.1, A. Guskov-0.1, D. Dedovich-0.9, M. Demichev-1, N. Kaurcev-1, D. Kharchenko-0.5, N. Koviagina-1, U. Kruchonak-0.4, I. Lyashko-1, I. Minashvili jr. -1, P. Morozov-1, A. Nozdrin-0.1, I. Potrap-1, T. Rudenko-0.9, P. Smolyanskiy-0.8, R. Sotenskii-1, A. Zhemchugov-0.2 (DLNP)  
Yu. Filippov-1, A. Ivanov-0.3 (VBLHEP),  
I. Titenkov-0.4, A. Zabaluev-0.2 (ATOM)

## Calorimeters

A. Cheplakov-1, E. Ladygin-1, (VBLHEP), I. Minashvili-1 (DLNP) - coordinators  
V. Kukhtin-1, S. Nagorny-1, N. Javadov-0.9, F. Ahmadov-0.2 (LHEP)  
A. Artikov-0.3, N. Atanov-0.3, V. Baranov-0.3, Yu. Davydov-0.5, V. Gerasimov-0.5, V. Glagolev-0.2, N. Kirichkov-0.3, S. Malyukov-1, V. Romanov-0.3, A. Shalyugin-0.5, A. Simonenko-0.3, V. Tereschenko-0.4, I. Vasilyev-0.3 (DLNP)  
S. Kulikov-0.1, M. Bulavin-0.1 (FLNP)

## Collaborators:

**CERN** (Switzerland), **CEA Saclay** (France), **INFN** (Italy), **German cluster**, **Univ. of Thessaloniki** (Greece), **Tomsk State University** (Russia), **Czech TU in Prague**, **Institute of Experimental and Applied Physics**, (Czech Republic), **X-Ray Imaging Europe** (Germany), **Freiburg; FMF, Universitat Freiburg** (Germany), **MPI Munchen** (Germany), **BNL** (USA), **INFN Milano** (Italy), **TRIUMF** (Canada) **Stockholm University** (Sweden), **Institute of Physics, Prague** (Czech Republik), **Charles University, Prague** (Czech Republik), **Univ. Blaise Pascal Clermont-Ferrand** (France), **Uni. Arizona** (USA), **Slovak Academy of Sciences, Bratislava** (Slovakia)

## ABSTRACT

The ATLAS detector upgrade programme follows the LHC upgrade scenario. The installation period is ongoing for the Phase-I upgrade programme which will continue until the end of 2020, so that LHC operation will start in March 2021 with the nominal c.m.s. energy of 14 TeV and significantly increased value of the ultimate luminosity to 1.5 times its current value,  $L \approx 3 \times 10^{34} \text{ cm}^{-2} \text{ s}^{-1}$ . The High Luminosity LHC (HL-LHC) is currently expected to begin its operation in second half of 2026, with  $L \approx 7.5 \times 10^{34} \text{ cm}^{-2} \text{ s}^{-1}$  corresponding to an average  $\mu = 200$  inelastic pp collisions per bunch-crossing and providing a total integrated luminosity of  $3000 \text{ fb}^{-1}$  by 2035. It will provide rather challenging environment for detector operation:



The high luminosity and the resulting high number of collisions per crossing will result in degradation of the physics performance of ATLAS unless the detector systems are upgraded. The JINR group is involved in the ATLAS Upgrade projects (both, Phase-I and Phase-II) for Muon Spectrometer and Calorimeters. In this document we report our main achievements in 2018-2019 and future plans for period of 2020-2023 and beyond.

## 1. MOTIVATION

To optimize the physics reach at each phase of the accelerator complex upgrades, ATLAS has devised a staged program in three phases, corresponding to the three long shutdowns, in step with the planned upgrades of the LHC. The Phase-I Upgrade is targeted primarily for installation during the second long shutdown (LS2) in 2019-2020, and Phase-II (HL-LHC era) during LS3 in 2024-26. Detector improvements for Phase-I should provide operation at the peak instantaneous luminosities of up to  $3 \times 10^{34} \text{ cm}^{-2} \text{ s}^{-1}$ . Improvements focus primarily on enhancing trigger capabilities in order to maintain good physics selectivity despite much higher data and background rates. Majority of the upgrade works are designed to satisfy Phase-II requirements, and will continue operating in ATLAS throughout the Phase-II period.

A total integrated luminosity of  $3000 \text{ fb}^{-1}$  will be provided by 2035. This will present a unique opportunity to significantly extend the study of the properties of the Higgs boson, probing a number of rare decays for the first time and significantly improving the precision of coupling measurements and allowing access to the Higgs self-coupling, along with providing substantial additional mass reach in searches for many signatures of new physics (in several cases well into the multi-TeV region). Although the increase of HL-LHC energy is moderate, the incredibly high statistics will allow rather precision measurements. The prospects of the ATLAS physics in the HL-LHC era are in the study of about 150M of Higgs bosons and 120K of Di-Higgs events recorded by the detector. It was shown that the HL-LHC would be able to probe Higgs couplings deviations w.r.t. SM with a precision of a few percent. It will be possible to measure rare Higgs decay and production modes as  $H \rightarrow \mu\mu$ ,  $H \rightarrow Z\gamma$  and  $ttH$ , and get evidence for Higgs pair-production.

The JINR group commitments in Phase-I upgrade were defined in the corresponding Technical

Design Reports [1-4] and Memoranda of Understanding [6-8]. Three of the ATLAS Phase-I Upgrade projects approved in 2014 are now advancing largely according to plan, while the New Small Wheel (NSW) is significantly delayed because of poor quality of the initially delivered PCB materials. Further plans of the Collaboration are published in the “ATLAS Phase-II Upgrade Scoping Document” [9]. In May 2019 the JINR Director has signed the MoU’s for the Dubna participation in Phase-II upgrade programme [10-13].

## 2. Upgrade of the ATLAS Calorimeters

The scope of the ATLAS Phase-I upgrades is limited to a few sub-detectors only. The readout of most of the systems will remain unchanged, limiting the capability of extending some of the parameters of the Level-1 trigger system. The existing LAr calorimeter trigger information is based on the concept of a “Trigger Tower” that sums the energy deposition across the longitudinal layers of the calorimeters in an area of  $\Delta\eta \times \Delta\phi = 0.1 \times 0.1$ . The Trigger Tower is created through several stages of on-detector analog electronics. The new finer granularity scheme is based on so-called “Super Cells”, which provide information for each calorimeter layer for the full  $\eta$  range of the calorimeter, as well as finer segmentation ( $\Delta\eta \times \Delta\phi = 0.025 \times 0.1$ ) in the front and middle layers of the EM barrel (EMB) and endcap (EMEC) as shown in Fig.1. The architecture of the upgraded calorimeter trigger electronics is depicted in Fig. 2, with the upgraded and new components outlined in red.

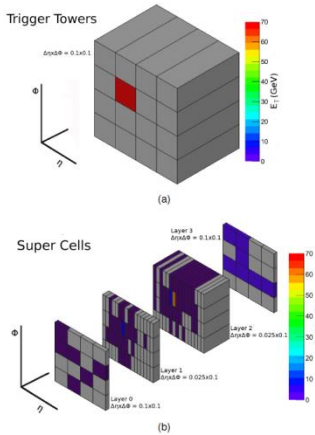

**Fig.1.** An electron (with 70 GeV of transverse energy) as seen by the existing Level-1 Calorimeter trigger electronics (a) and by the proposed upgraded trigger electronics (b).

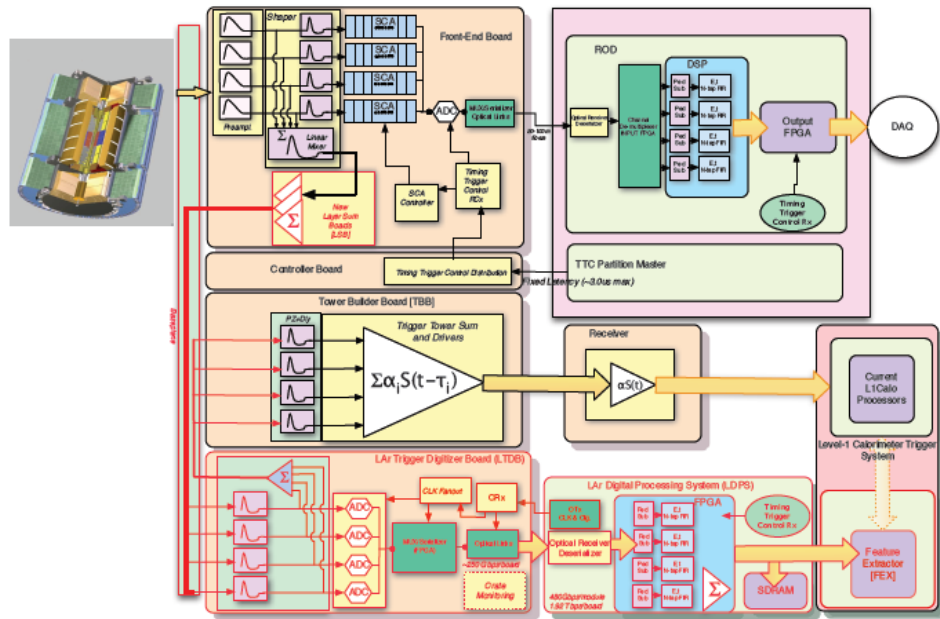
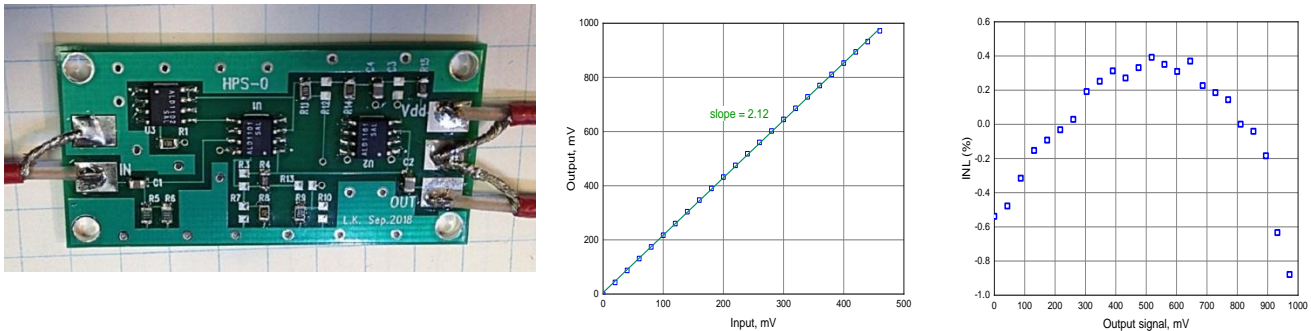

**Fig.2.** Schematic block diagram of the Phase-I upgrade LAr trigger readout architecture. The new components are indicated by the red outlines and arrows.

Baseplane for the Hadronic Endcap Calorimeter (HEC) Front-End readout crate was developed by the JINR team and produced in collaboration with colleagues from TRIUMF (Canada). The new baseplanes will allocate new slot(s) for the LAr Trigger Digitizer Boards (LTDB), while keeping the other front end electronics boards slots intact. In addition, a much larger number of signals are transferred from the FEBs to the LTDB than are currently used in the trigger chain.

JINR team participated in the development of the LTDB boards and digital processing system (LDPS). These boards will be installed in the LAr crates during LS2 and will remain there for Run4.

A test bench was created for testing the HEC analog schemes and production of the prototypes. Several prototypes of the HEC shaper were made based on CMOS technology. Fig.3 presents the view of the latest version of the shaper and preliminary tests of its non-linearity.



**Fig.3.** HEC shaper prototype and the non-linearity measurements.



In the HILUM-2 experiment at Protvino we study performance of the mini-modules of the ATLAS LAr calorimeters with high-intensity proton beams at U-70. The goal is to investigate the influence of the space charge built in thin LAr gap on the shape of the calorimeter signal. We have designed and produced the beam chamber (Fig. 4) and corresponding electronics for the beam profile monitoring.

**Fig.4.** Freon beam chamber in HILUM-2 experiment at U-70 (Protvino).

The first results show good quality of the experimental data. Preliminary estimates of the ion mobility are in a good agreement with the previous measurements. The experiment will continue within the Collaboration activity aimed on development of the global model for the ATLAS calorimeters behavior in the HL-LHC era.

The radiation hardness tests were continuing at the IBR-2M reactor. Good results for the prototypes of the baseplane allowed the ATLAS Collaboration to approve application of the HEC baseplane for the LAr Phase-II upgrade. The tests of the multilayer PCB's made of different materials including G10, FR4, Rogers, Arlon 85N and Kapton and further mechanical and electrical measurements resulted in recommendations for applications of the Kapton and Arlon materials. The optical fibers and pigtailed used for signal transmission were recently exposed to the fast neutron beam and will be tested soon.

In coming years the group interests will be focused on the preparation for the Phase-II upgrades. The LAr readout electronics will be replaced during Phase-II upgrade, including readout electronics of the "cold" preamplifiers for HEC. The analog blocks will be integrated into CMOS IC's, and we will develop the final prototype made of discrete CMOS transistors with the functionality close to the final circuit. The test bench for testing the prototype will be constructed.

This modernization will be done in collaborative work with TRIUMF, Canada. Testing of the solid state amplifier for HEC will be done at CERN facilities.

A new R&D will start for preparation for the massive production of the optical fiber patch cords including production of the prototypes, their optical and mechanical tests, irradiation tests at IBR-2M and U-70, etc. Special test bench will be equipped with the Optical Time Domain Reflectometer. The JINR group commitments as presented in the Phase-II MoU [10] are:

- Preamp-Shaper and HEC Preshaper ASICs - *HEC input stage design and testing*;
- Optical Link Components - *Production and testing of optical pigtails*;
- FEB2 - *Develop analog circuit and testing*;
- Front-End Power Distribution System - *Procurement of parts*;
- LAr Signal Processor Hardware - *Procurement of parts*;

Scintillation detector modules located in the area between the central barrel and the extended barrel (gap scintillators) and extending to the region between the LAr barrel and endcap EM calorimeters (crack scintillators), cover pseudorapidity in the range  $1.2 < \eta < 1.6$ .

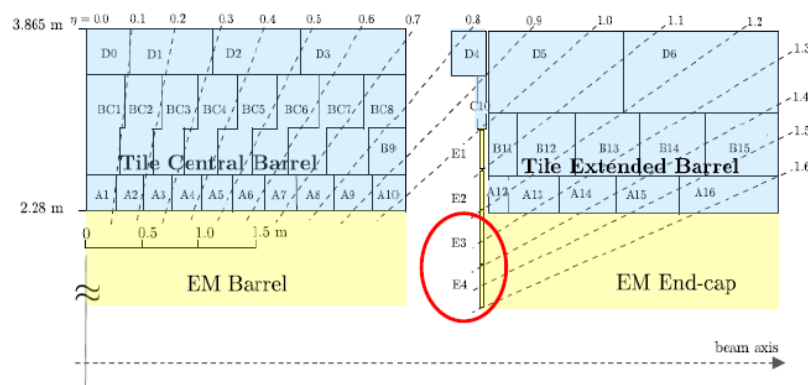

Positions of gap scintillators (E1 and E2) and crack scintillators (E3 and E4) are shown in Fig.1. During Run2 crack scintillators were exposed to a high level of radiation. This required the replacement of crack scintillators during the LS2.

**Fig.5.** Position of gap and crack scintillators. Crack scintillators E3 and E4 position highlighted in red.

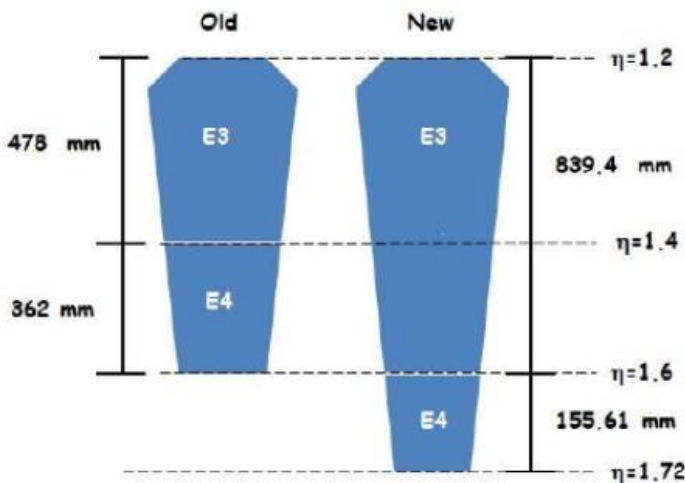

In order to increase the electron reconstruction efficiency in the EM calorimeter region it was decided to increase the length of the E3+E4 module. The new geometry of the crack scintillators is presented in Fig. 6. New E3+E4 module covers a region  $1.2 < \eta < 1.72$ .

**Fig.6.** Old and new geometry of the crack scintillators.

Aluminum cans for all E3+E4 modules were designed and manufactured by our colleagues from the Michigan State University.

All modules were assembled and tested at CERN. Fig.7 presents the response of one of the module to the  $^{90}\text{Sr}$  irradiation.

Assembled modules were installed on one side of the Tile calorimeter in September 2019. Assembling of the rest of modules will be finished in November 2019 and all modules will be

installed in the ATLAS cavern in November-December 2019. The JINR group members actively participate in the assembly, testing and installation of modules.

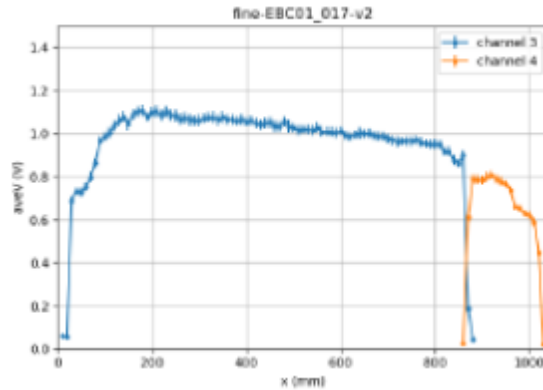

**Fig.7.** Response of one of the modules to beta source scanning.

The JINR group members are actively involved in the development of the new readout electronics for Tile hadron calorimeter. As a first step the Collaboration decided to design so-called Demonstrator - a prototype for replacement of existing drawers.

The aim of the Demonstrator project is to create the full-featured upgraded electronics (drawer) of the Tile hadron calorimeter supplemented with the trigger system based on the summing of the analog signals to make it (electronics) compatible with the existing system. One long barrel module with the upgraded electronics was created and tested during 2016-18. It provided experience with the major components of the new structure and helped to determine the necessary improvements. Final version of the demonstrator (Fig.8) was completed in 2019 and inserted in the TileCal module in July 2019 after tests in laboratory. Demonstrator is showing good stability in terms of link, temperature, etc.



**Fig.8.** Demonstrator with new electronics during tests in laboratory.

We continue to maintain the Tile calorimeter during data taking and during LHC shutdowns. As a part of Phase-II activity our group plans to participate in the modernization of a low voltage power supply system. In particular, our group is responsible for production of auxiliary control boards, auxboard cables and connectors.

ATLAS Collaboration decided to install in front of the endcap calorimeter a new detector – high granularity timing detector (HGTD). JINR group has been participating in the HGTD activity since 2018. The group's responsibility is to design the detector services. Group members are involved in the tests of sensors as well. We participated in a few beam tests at CERN and DESY in 2018-



19 and in beam test data analysis. We will continue design work on HGTD, including the layout of the detector, development of tooling for the assembly and installation of the detector in the ATLAS cavern. Another part of the work includes study of semiconductor sensors, participation in the assembly of modules and their testing. Preproduction of sensors and Module 0 production will start in 2021 with production of remaining modules in 2022-24. Start of the detector assembly is scheduled for the second half of 2023. The TDR for HGTD should be submitted to the LHCC in April 2020, and the participating group's responsibilities will be finalized in MoU by the end of 2020.

### 3. Upgrade of the ATLAS Muon Spectrometer

Presently (within the Phase-I period), two Micromegas chamber production lines are constructed and successfully operate at the DLNP JINR in the framework of the NSW ATLAS project of the Phase-I Upgrade (Fig. 8). The first line provides production and testing of Micromegas chambers for the outer part of the large sectors of NSW ATLAS (type LM2). This line is using for production of NSW readout planes which cover the area of 384 m<sup>2</sup> out of the total area of 1200 m<sup>2</sup>. Component materials are supplied from CERN in a centralized fashion for all participants of the project. The second line, so-called “Dubna bulk lab”, aims at complete cycle of Micromegas chambers production with the active region size of up to 55x80 cm<sup>2</sup>. This line is used for the ATLAS R&D and obviously gives the institute employees an opportunity to use the chambers in different physics experiments and in applied studies more efficiently.

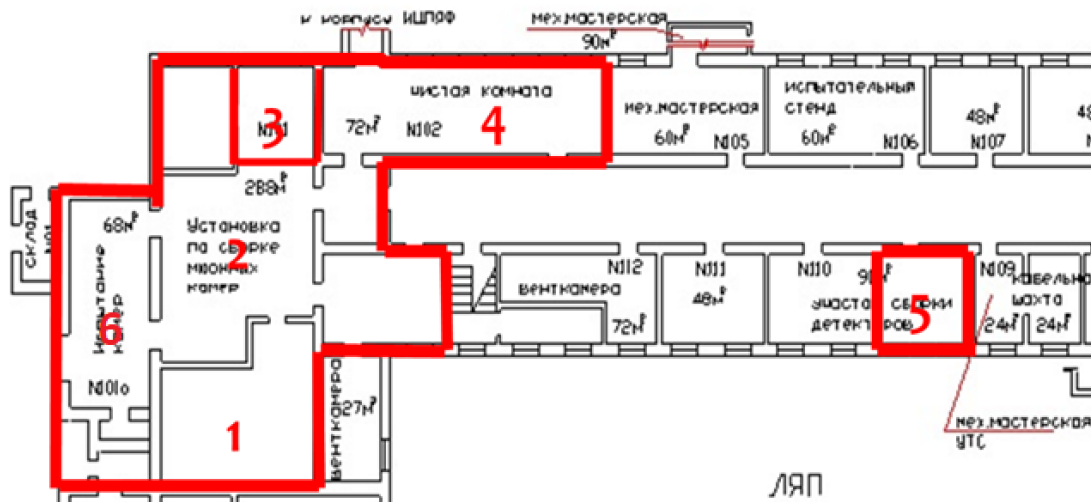
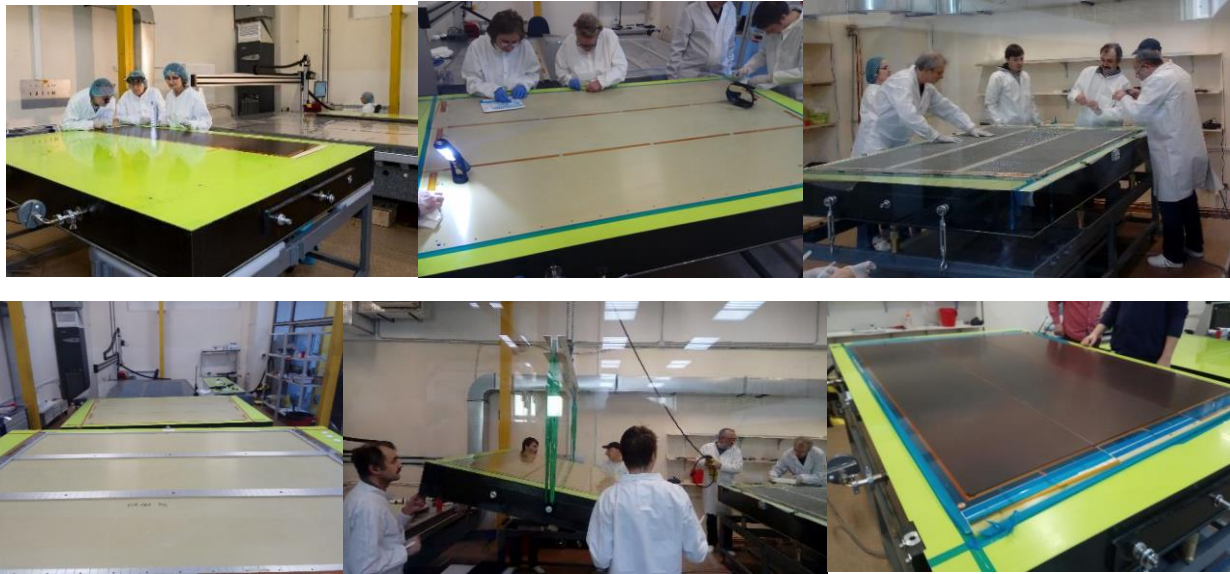

**Fig. 9.** MM production lines: 1 – panel production, 2 – cosmic stand, 3 – gas leak tests, 4 – quadruplets assembly and testing, 5 – room for panel washing, 6 – “Dubna bulk lab”

The production lines comprises 6 premises, as shown in Fig. 9 –clean room (72 m<sup>2</sup>, purity class ISO 7) for production of read-out panels and testing of their geometrical characteristics; hall (~150 m<sup>2</sup>) for testing quadruplets at the cosmic rays stand; room (~25 m<sup>2</sup>) for gas leak testing of the panels; clean room (~50 m<sup>2</sup>, purity class ISO 6) for assembly and testing of quadruplets; premises (~25 m<sup>2</sup>) for panels washing and room (72 m<sup>2</sup>) for the second production line. The air-conditioning system and supply/extraction ventilation have been completely upgraded in the clean room for the readout panel assembly. In both clean rooms the control of temperature and humidity is carried out ( $\pm 0,5^{\circ}\text{C}$  and  $\pm 10\%$ ).

**3.1. ATLAS NSW Micromegas production line.** DLNP ATLAS group is responsible for the production and testing of the 64 (+4 spares) RO panels and 32 (+2 spares) quadruplets. These days the mass-production is in full swing.

After the production, the geometrical characteristics (thickness and planarity) of each panel is tested, PCB top-bottom alignment is measured, gas tightness and basic electrical tests are also performed. Some details about the MM panel production and testing are presented below in Fig.10-13.



**Fig. 10.** Stages of the panel production

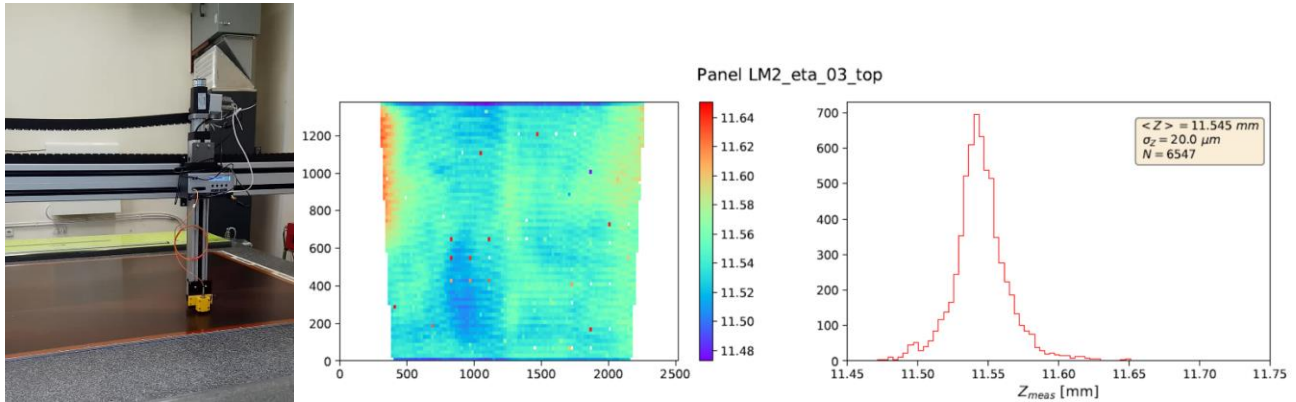

**Fig. 11.** Stand for semi-automatic measurements of geometrical characteristics and one of the measurement results.

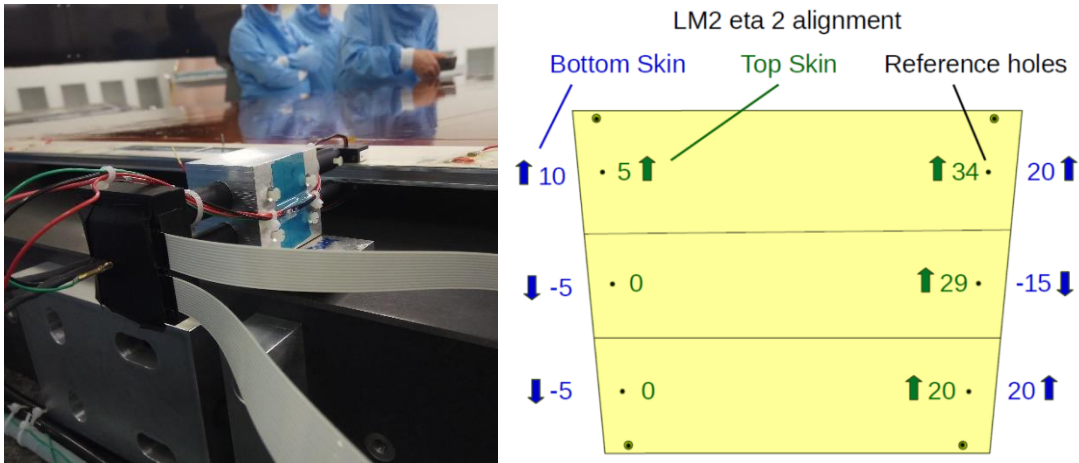

**Fig. 12.** Optical tool for the panel PCBs top-bottom alignment measurements and one of the measurement results.

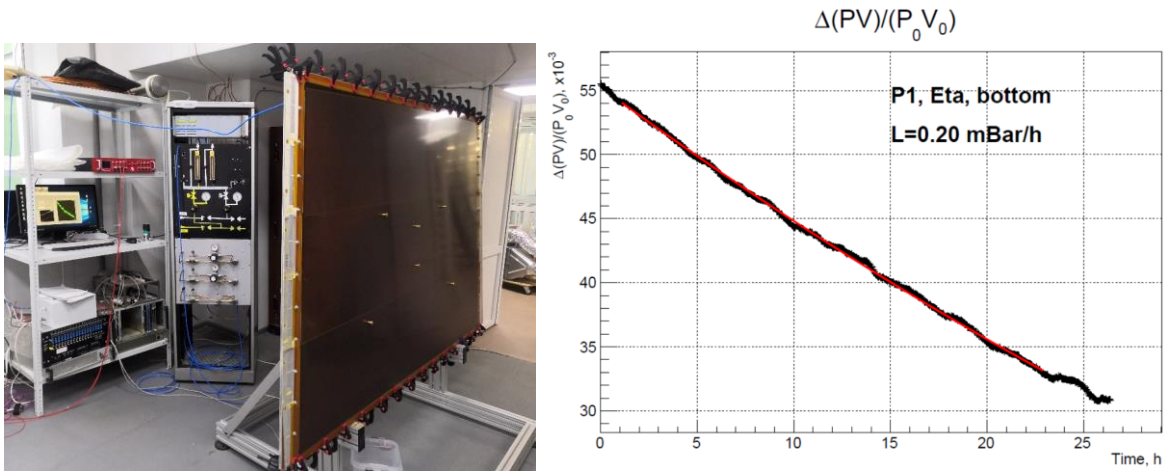

**Fig. 13.** Stand for gas tightness measurements and one of the measurement results

After the tests, the panels are washed in accordance with a special procedure and dried in the oven. Next step is the Quadruplet assembly in the clean room (Fig. 14) and HV tests in dry air and in ArCO<sub>2</sub> and gas leak test.



**Fig. 14.** Quadruplet assembly procedure in the clean room.

After the assembly and HV tests, Quadruplets are passed through the measurement of geometrical characteristics and gas leak tests. The final test for the Quadruplets is the functionality test at the cosmic ray bench (Fig.15).



**Fig. 15.** Quadruplet preparation for the functionality test at the cosmic ray bench.

By November 2019, 45 RO panels and 12 Quadruplets have been produced and successfully tested. Ten Quadruplets were sent to CERN: 8 of them for the NSW wedge assembly and other 2 for another purposes (1 for the mechanical integration and 1 for the 18/45 mesh study) and will never go into the ATLAS pit. Meanwhile, the first large double wedge assembly with LM2 (JINR) and LM1 (CEA Saclay) was completed at CERN (Fig. 16) with active participation of the JINR team.

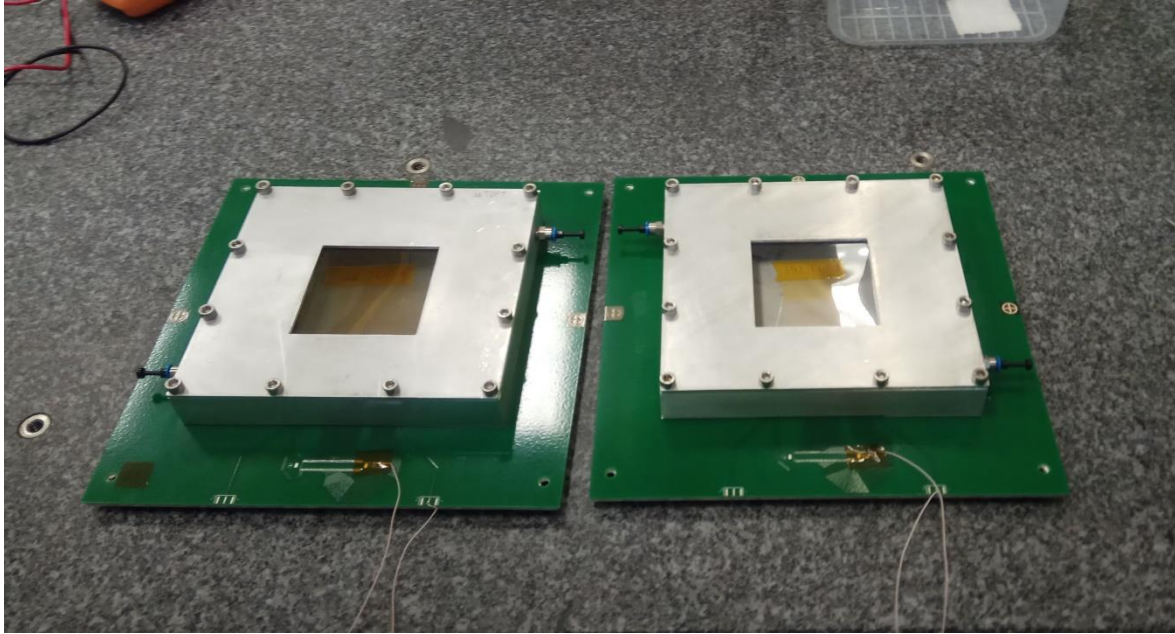

**Fig. 16.** The first double wedge for the NSW in BB5 CERN.

LM2 Quadruplets production for the NSW side A should be finished in March 2020 and should be completed for the NSW-C in December 2020. Installation of NSW-A is scheduled for 2020 and NSW-C for 2021 during the LHC EYTS (end-of-year technical stop).

It should be noted that in order to fulfill the JINR commitments to ATLAS, 2 persons from the DLNP ATLAS group are permanently presented at CERN for the LM2 wedge and NSW structure integration and testing, and this work will continue until the full NSW commissioning in 2022.

**3.2. “Dubna bulk lab”.** A complete cycle line for Micromegas chambers production was established in 2018, and production and testing of Micromegas was started. The fabrication technology, as well as performance of the first assembled prototype was published in Journal of Instrumentation (2019 JINST 14 T07004). Figure 17 shows two produced Micromegas detectors in the gas volumes for the different mesh study.



**Fig. 17.** Two Micromegas detectors in gas volumes for the different mesh study.

In accordance with the MoU for the ATLAS Phase-II Upgrade the DLNP ATLAS group is involved in the development and production of the new resistive plate chambers (RPC) for the ATLAS Muon spectrometer. In particular, we will do the following [11]:

- RPC BI readout panels production;
- Gas system design, production, installation;
- Power distribution design;
- Power distribution production and installation;
- Surface commissioning, installation and commissioning in the pit.

Preparation for this activity is ongoing. Active work should begin in mid-2020.

**3.3. Background Monitoring System** with Si pixel TPX detectors, which was developed and built with active participation of the JINR team, will be extended by the addition of new pixel GaAs TPX detectors with higher efficiency for gamma and neutron detection.

ATLAS Collaboration considers seriously safety and radioprotection aspects of the detector operation. The JINR group in collaboration with Tomsk University, Russia, Czech Technical

University in Prague, Institute of Experimental and Applied Physics, Czech Republic and CERN made a proposal for development of a novel technology for semiconductor pixel detectors based on GaAs:Cr technology. These detectors have significantly higher efficiency for registration of gamma's and neutrons than the standard Si-based detectors.

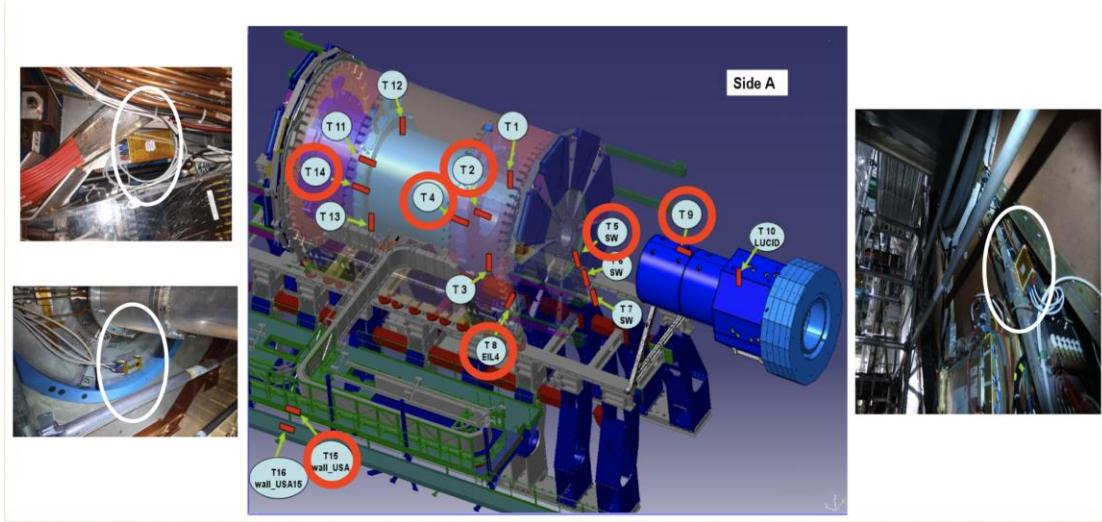

**Fig. 18.** Scheme of the GaAs monitors placing in the ATLAS detector, and photos of individual detectors at their locations.

Fig. 18 shows scheme of the GaAsPix monitors in the ATLAS detector. The work is ongoing on development of the effective pattern recognition algorithms. These monitors allow registration of the neutron induced activity and the neutron fluence measurements at various locations of the ATLAS detector. Registration and identification of the background particles is carried out on-line. The work is ongoing to get the live pictures and the data available in Dubna for the monitoring and analysis.

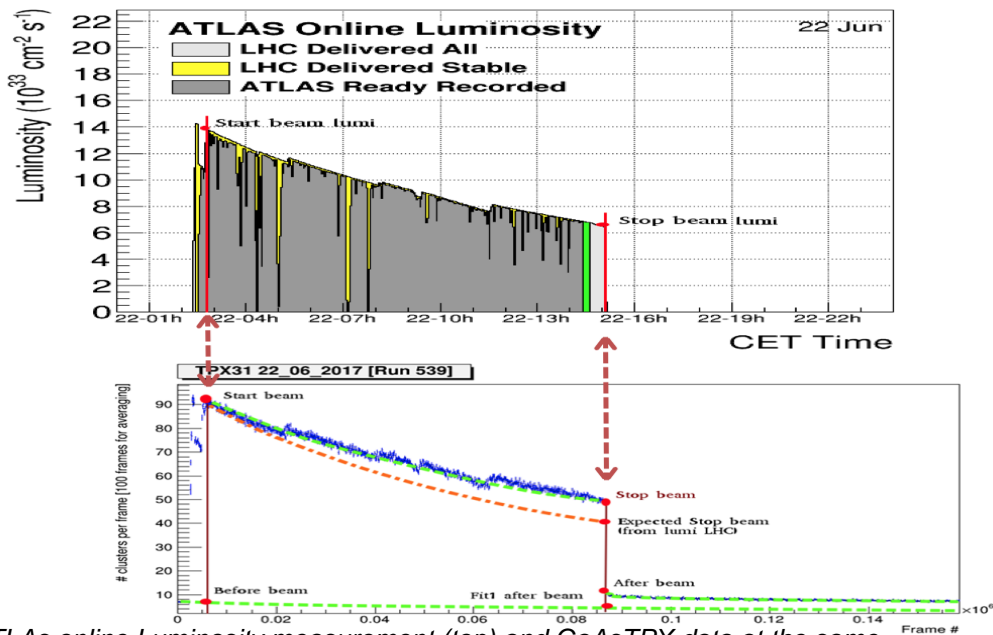
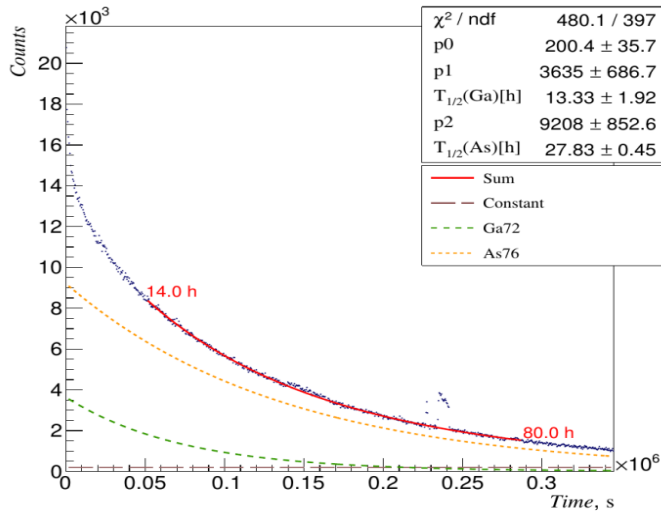

**Fig. 19.** ATLAS online Luminosity measurement (top) and GaAsTPX data at the same time (bottom)

During 2017 ten new GaAs TPX detectors were mounted in the ATLAS cavern after calibration and detail testing in DLNP JINR. All detectors showed stable performance during ATLAS operation periods in 2017 and 2018. The example of the data measured during this period is shown at Fig.19. The data have being analyzed and results will be published in the nearest future.

By using the new GaAsTPX detectors the following new background parameters could be measured at the locations of the detectors in the cavern:

- Neutron background variations (Fig. 20);
- Charge/neutral background fraction variation.



**Fig. 20.** An example of neutron background estimation via decay curve of GaAs radioactive isotopes activated by the neutron background component.

#### 4. Human Resources

A total number of personnel in the JINR group participating in the ATLAS Upgrade program are 53 providing 35 FTE. They are 31 physicists, 17 engineers and 5 technicians. Major part of them is engaged in the project for many years. They have well recognized reputation within the Collaboration and beyond, solid background and necessary skills to fulfil all our obligations.

It worth noting that within the JINR ATLAS team the upgrade related part has no manpower overlap with those involved in the physics analyses.

#### 5. Estimation of Budget

Our commitments in the ATLAS Phase-I Upgrade should be fulfilled by the end of 2020. The work on Phase-II already goes in parallel. As far as the ATLAS Phase-II concerned, the JINR obligations are presented in the corresponding MoU already signed by the JINR Director, with total CORE<sup>1</sup> costs of ~3 MCHF. These expenses are included in the Seven Year Plan for the Development of JINR (2017-2023). Our goal is to maximize the JINR in-kind contribution. Some

<sup>1</sup> The CORE (Cost of Resource Exchange) value identifies only the deliverable’s direct cost; it excludes associated manpower costs, exchange rate fluctuations, prototyping cost, R&D costs, etc. It includes items such as components, industrial stuff (but not institute staff) for production, outsourced parts of assembly, installation, test and commissioning.

additional work has to be done upon request from the Ministry of Science and High Education providing extra funding. The breakdown of the planned expenses is presented below.

Within the upgrade project for the ATLAS Calorimeters we will continue R&D work on development of the front-end readout electronics, new scintillators, testing and products certification. In particular,

- Development of the test bench equipped with Optical Time Domain Reflectometer for testing patch-cords, purchase of optical fibers for prototyping (10kUSD);
- Irradiation tests at IBR-2 (2 runs per year) – purchase of electronic equipment (5kUSD), materials (rad.hard. cables, connectors, samples) (12kUSD);
- Irradiation tests at U-70 (1-2 runs per year) – equipment (4kUSD) and samples (same as for IBR-2 tests) (6kUSD);
- HiLum2 experiment at Protvino - HV monitor for beam chambers (3kUSD); CAEN timing unit (3kUSD) and cryogenics (ageing) items (3kUSD).

Within the upgrade project for Muon Spectrometer we will continue intensive mass-production of the MicroMegas chambers and quadruplets assembly for the NSW projects. The chambers are transported to CERN and our team participates in their integration in the NSW structure and final detector commissioning.

- LM2 quadruplets production, transportation, integration and final commissioning (120kUSD);
- R&Ds for sRPC – 50 kUSD;
- Maintenance work on the GaAs:Cr monitors – 30kUSD.

## 6. SWOT Analysis

The approach developed by our Dutch colleagues from the Nikhef [12] was used as a good starting point for the present analysis.

### **Strength**

1. Participation in a large and challenging international projects in a competitive and high-tech, internationally oriented, research arena.
2. Excellent scientific publication and citation records.
3. Collaborations with groups at the leading international accelerator center (CERN) and other physics laboratories.
4. Large interest of the general public and media.

### **Weaknesses**

1. The growing age of staff scientists and engineers.
  - The efforts are undertaking to attract young students to join the project: the average age of the Muon group members is 41 and 10 persons are below 30.
  - JINR and CERN are the founder of the Russian Language Teacher Programme [14].

### **Opportunities**

1. LHC shows huge discovery potential which attracts scientists at all levels (master students, PhD students, postdocs and staff physicists alike).
2. JINR experiments often require completely new and challenging technologies and ATLAS offers our technical departments possibilities and contacts with new research communities. New technology of MicroMegas is already brought to JINR.
3. The experience gained in the ATLAS experiment is shared with our colleagues from the NICA project.
4. The BiG Grid - e-science grid-project JINR-LCG2 - provides researchers at JINR with



state-of-the-art computing services and an opportunity to establish contacts and/or collaborations with many other research disciplines.

### **Threats**

1. Project delays due to lack of funding for large projects (~3 M€ investment cost)
  - ATLAS physicists are very active in the relevant committees that should attract additional funding. JINR team has already brought the LHC upgrade plans to the attention of MSHO RF. CERN management is also helping us to get funding.
2. Some cases of excessive commitments for a single person.
  - Negotiating with the directorates on a proper balance of responsibilities.

## **7. Conclusions**

The JINR is among the founders of the ATLAS experiment and continues an active participation in various activities within the Collaboration, including data analysis, detector operation & maintenance, and modernization of the detector subsystems.

During past years the JINR group made significant contribution to the upgrade of the ATLAS detector subsystems – Muon Spectrometer and Calorimeters. We have fulfilled successfully all our obligations within MoU's for the ATLAS Phase-I upgrade programme. The MoU's for the Phase-II have been signed and the work is going on.

All these activities will continue as detailed above in the document. We ask PAC PP to approve continuation of the JINR group participation in the ATLAS Upgrade project for the next 3 years (2021-2023).

## **References**

1. CERN-LHCC-2013-006, ATLAS New Small Wheel TDR
2. CERN-LHCC-2013-007, ATLAS Fast Tracker TDR
3. CERN-LHCC-2013-017, ATLAS Liquid Argon Calorimeter Phase-I Upgrade TDR
4. CERN-LHCC-2013-018, TDR for the Phase-I Upgrade of the ATLAS TDAQ System
5. CERN-LHCC-2015-009, ATLAS Forward Proton TDR
6. CERN-RRB-2014-050, Construction of the ATLAS New Small Wheel (NSW) Sub-Detector
7. CERN-RRB-2014-051, Upgrade of the Liquid Argon Calorimeter Trigger electronics
8. CERN-RRB-2014-052, Upgrade of the ATLAS Tile Calorimeter
9. CERN-LHCC-2015-020, ATLAS Phase-II Upgrade Scoping Document
10. CERN-MoU-2019-019, ATLAS Liquid Argon Calorimeter Phase-II Upgrade
11. CERN-MoU-2019-021, ATLAS Muon Spectrometer Phase-II Upgrade
12. CERN-MoU-2019-020, ATLAS Tile Calorimeter Phase-II Upgrade
13. CERN-MoU-2019-017, ATLAS Trigger/DAQ Phase-II Upgrade
14. <https://indico.cern.ch/event/587633/timetable/>

PROJECT ENDORSEMENT LIST

UPGRADE OF THE ATLAS DETECTOR

ATLAS COLLABORATION

Theme 02-0-1081-2009/2019

PROJECT LEADER – Alexander Cheplakov (VBLHEP)

APPROVED BY JINR DIRECTOR

\_\_\_\_\_  
SIGNATURE

\_\_\_\_\_  
DATE

ENDORSED BY

JINR VICE-DIRECTOR

\_\_\_\_\_

\_\_\_\_\_

CHIEF SCIENTIFIC SECRETARY

\_\_\_\_\_

\_\_\_\_\_

CHIEF ENGINEER

\_\_\_\_\_

\_\_\_\_\_

HEAD OF SCIENCE ORGANIZATION DEPARTMENT

\_\_\_\_\_

\_\_\_\_\_

LABORATORY DIRECTOR

\_\_\_\_\_

\_\_\_\_\_

LABORATORY CHIEF ENGINEER

\_\_\_\_\_

\_\_\_\_\_

PROJECT LEADER

\_\_\_\_\_

\_\_\_\_\_

PROJECT DEPUTY LEADERS

\_\_\_\_\_

\_\_\_\_\_

ENDORSED

RESPECTIVE PAC

\_\_\_\_\_

\_\_\_\_\_

**Schedule proposal and resources required for the implementation of the Project**

**Upgrade of the ATLAS Detector**

(Project title)

Expenditures, resources, financing sources		Costs (k\$) Resource requirements	Proposals of the Laboratory on the distribution of finances and resources		
			1 <sup>st</sup> year	2 <sup>nd</sup> year	3 <sup>rd</sup> year
Expenditures	Main units of equipment, work towards its upgrade, adjustment etc.	150	70	45	35
	Construction/repair of premises				
	Materials	110	60	25	25
Required resources	Standard hour				
	Resources of – Laboratory design bureau; – JINR Experimental Workshop; – Laboratory experimental facilities division; – reactor; – computer. Operating costs.	1200	400	400	400
Financing sources	Budgetary resources	260	130	70	60
	External resources	Contributions by collaborators.  Grants.	6  (120)	2  (40)	2  (40)

PROJECT LEADER

**Estimated expenditures for the Project “Upgrade of the ATLAS Detector”**

(full title of Project)

Expenditure items	Full cost	1 <sup>st</sup> year	2 <sup>nd</sup> year	3 <sup>rd</sup> year
Direct expenses for the Project				
1. Accelerator, reactor	1200h	400	400	400
2. Computers	h			
3. Computer connection	k\$			
4. Design bureau	standard hour			
5. Experimental Workshop	standard hour			
6. Materials	110k\$	60	25	25
7. Equipment	150k\$	70	45	35
8. Construction/repair of premises	k\$			
9. Payments for agreement-based research	k\$			
10. Travel allowance, including:	290k\$			
a) non-rouble zone countries		90	90	100
b) rouble zone countries		4	4	2
c) protocol-based				
Total direct expenses	550	224	164	162

PROJECT LEADER

LABORATORY DIRECTOR

LABORATORY CHIEF ENGINEER-ECONOMIST

ЛИСТ СОГЛАСОВАНИЙ ПРОЕКТА

«МОДЕРНИЗАЦИЯ ДЕТЕКТОРА АТЛАС»

Эксперимент АТЛАС на LHC

тема 02-0-1081-2009/2019

руководитель проекта - ЧЕПЛАКОВ А.П., нач.сектора ЛФВЭ

УТВЕРЖДЕН ДИРЕКТОРОМ ОИЯИ

\_\_\_\_\_

подпись

\_\_ \_\_

дата

СОГЛАСОВАНО

ВИЦЕ-ДИРЕКТОР ОИЯИ

\_\_\_\_\_

\_\_ \_\_

ГЛАВНЫЙ УЧЕНЫЙ СЕКРЕТАРЬ

\_\_\_\_\_

\_\_ \_\_

ГЛАВНЫЙ ИНЖЕНЕР

\_\_\_\_\_

\_\_ \_\_

НАЧАЛЬНИК НОО

\_\_\_\_\_

\_\_ \_\_

ДИРЕКТОР ЛАБОРАТОРИИ

\_\_\_\_\_

\_\_ \_\_

ГЛАВНЫЙ ИНЖЕНЕР ЛАБОРАТОРИИ

\_\_\_\_\_

\_\_ \_\_

РУКОВОДИТЕЛЬ ПРОЕКТА

\_\_\_\_\_

\_\_ \_\_

ЗАМ. РУКОВОДИТЕЛЯ ПРОЕКТА

\_\_\_\_\_

\_\_ \_\_

ОДОБРЕН

ПКК ПО НАПРАВЛЕНИЮ

\_\_\_\_\_

\_\_ \_\_

**Предлагаемый план-график и необходимые ресурсы для осуществления  
проекта «Модернизация детектора АТЛАС»**

Наименования затрат, ресурсов, источников финансирования		Стоимость (тыс. долл.). Потребности в ресурсах	Предложение лаборатории по распределению финансирования и ресурсов		
			1 год	2 год	3 год
Затраты	Основные узлы оборудования, работы по его обновлению, наладке и т.п.	150	70	45	35
	Материалы	110	60	25	25
Необходимые ресурсы	Нормо-час Ресурсы реактора ИБР-2М (часы)	1200	400	400	400
Источники финансирования	Бюджетные средства Затраты из бюджета, в том числе инвалютные средства	260	130	70	60
	Внебюджетные средства Вклады коллаборантов. Средства по грантам.	6 (120)	2 (40)	2 (40)	2 (40)

РУКОВОДИТЕЛЬ ПРОЕКТА

Смета затрат по проекту «Модернизация детектора АТЛАС»

NN пп	Наименование статей затрат	Полная стоимость тыс.долл.	1 год	2 год	3 год
	Прямые расходы на Проект				
1.	Ускоритель, реактор (часы)	1200	400	400	400
2.	Материалы	110	60	25	25
3.	Оборудование	150	70	45	35
4.	Оплата НИР, выполняемых по договорам				
5.	Командировочные расходы, в т.ч.	290	94	94	102
	а) в страны нерублевой зоны	280	90	90	100
	б) в города стран рублевой зоны	10	4	4	2
	в) по протоколам				
	Итого по прямым расходам:	550	224	164	162

РУКОВОДИТЕЛЬ ПРОЕКТА

ДИРЕКТОР ЛАБОРАТОРИИ

ВЕДУЩИЙ ИНЖЕНЕР-ЭКОНОМИСТ ЛАБОРАТОРИИ