

Investigation of neutrino properties with  
the low-background germanium spectrometer vGEN

# vGEN

CODE OF THEME 03-2-1100-2010/2021

V.V.Belov, V.B.Brudanin, V.A.Evsenkin, S.A.Evseev, D.V.Filosofov, M.V.Fomina,  
L.Grubchin, U.B.Gurov, A.Kh.Inoyatov, S.L.Katulina, S.V.Kazarcev, S.P.Kiyanov,  
A.S.Kuznecov, A.V.Lubashevskiy, D.V.Medvedev, D.V.Ponomarev, D.S.Pushkov,  
A.V.Salamatin, K.V.Shakhov, E.A.Shevchik, M.V.Shirchenko, Z.Kh.Khukhvatov,  
V.G.Sandukovsky, S.V.Rozov, I.E.Rozova, V.P.Volnikn, I.V.Zhitnikov, E.A.Yakushev

Laboratory of Nuclear Problems, JINR

NAMES OF PROJECT LEADERS: V.B.Brudanin

NAME OF PROJECT DEPUTY LEADERS: A.V.Lubashevskiy, E.A.Yakushev

DATE OF SUBMISSION OF PROPOSAL OF PROJECT TO SOD \_\_\_\_\_

DATE OF THE LABORATORY STC \_\_\_\_\_ DOCUMENT NUMBER \_\_\_\_\_

STARTING DATE OF PROJECT January 2022 (FOR EXTENSION OF  
PROJECT — DATE OF ITS FIRST APPROVAL) 07.02.2014

## CONTENTS

ABSTRACT .....	3
INTRODUCTION .....	4
STATE-OF-THE-ART OF THE INVESTIGATIONS .....	5
DESCRIPTION OF THE PROPOSED RESEARCH .....	8
RESULTS FROM THE PREVIOUS INVESTIGATIONS .....	13
PUBLICATIONS AND REPORTS .....	15
ESTIMATION OF HUMAN RESORCES .....	16
SWOT ANALYSIS .....	18

## ABSTRACT

The  $\nu$ GEN project is aimed to investigate fundamental properties of neutrino at close vicinity of the reactor core of Kalinin Nuclear Power Plant (KNPP). The search for the coherent scattering of the neutrino from the reactor is performed within the project. This process has never been observed for the low-energy reactor neutrino. While observing, it opens a way to search of non-standard neutrino interaction and applied research, like reactor monitoring. The  $\nu$ GEN experimental setup is constructed under the reactor #3 of KNPP at a distance of about 10 m from the center of the reactor's core under an enormous antineutrino flux of more than  $5 \cdot 10^{13}$   $\nu/\text{cm}^2/\text{s}$ . A special lifting mechanism allows moving the spectrometer away from the reactor core, suppressing main systematic errors caused by possible long-term instability and neutrino flux. Signals from neutrino scattering are detected with help of high purity low-threshold germanium detectors. New detectors in  $\nu$ GEN project with an ultimate resolution of about 80 eV (FWHM) with masses of more than 1 kg each are used to detect neutrino signals. It would allow exploring an energy region below 250 eV. A total mass of about 5.5 kg will be used for an upgrade of the experimental setup. Detectors at KNPP are surrounded by passive and active shielding reducing the external background in the region of interest. First coherent neutrino scattering from reactor would be observed in case of desired background level and energy resolution at KNPP are achieved. This setup would also open a way to investigate the coherent neutrino scattering with a much higher sensitivity to the non-standard neutrino interactions. The first phase of the project (GEMMA-I) sets up the world best upper limit for the Magnetic Moment of Neutrino (MMN) of  $< 2.9 \cdot 10^{-11} \mu_B$  (90% CL). The experimental sensitivity with  $\nu$ GEN project will be improved to the level of  $\sim (5-9) \cdot 10^{-12} \mu_B$  after several years of data taking. The requested financial support for the project is 467 k\$.

## INTRODUCTION

Neutrino plays important role in modern physics. This particle was postulated by Wolfgang Pauli already in 1930, then detected in 1956, but still many its properties are unknown. Measurement of neutrino properties is a very important task for particle physics, astrophysics and cosmology. Being one of the most abundant particle in the Universe its detection is very challenging due to a weak interaction with matter. To investigate its properties, it is required to have a very strong source of the neutrinos and apply various methods for the suppression of background events.

Coherent Elastic Neutrino-Nucleus Scattering (CEvNS) is a process predicted by the Standard Model, but has not been observed yet for the reactor neutrino. Its cross section is enhanced by several orders of magnitude in comparison with other neutrino interaction and it is being proportional to the number of nuclear target neutrons squared,  $N^2$ . The detection of low energy neutrinos via CEvNS on a nuclear target is a sought-after goal in modern neutrino physics. The detection of this process would be an important test of the Standard Model. Due to a low cross section and a very low energy deposition, it is not easy to observe this process. Such observations can also help for the search of non-standard neutrino interactions, sterile neutrinos and other investigations. A magnetic moment is a fundamental parameter of the neutrino and its investigation may lead to results beyond the standard concepts of elementary particle physics and astrophysics. The Minimally Extended Standard Model predicts a very small magnetic moment value for the massive neutrino ( $\mu_\nu \sim 10^{-19}\mu_B$ ) that cannot be observed in any existing experiment. However, there are a number of theory extensions beyond the Standard Model, where the magnetic moment of neutrino could be at the level of  $10^{-(10-12)} \mu_B$  for Majorana neutrino. The observation of neutrino magnetic moment (NMM) value higher than  $10^{-14} \mu_B$  would be an evidence of New Physics and would give an evidence that neutrino is a Majorana particle.

The vGEN experiment aimed to investigate these neutrino properties. This experiment is an evolution of our previous projects GEMMA. It is going to move our investigations on a new level of sensitivity. The experimental setup is located at about 10 m from the 3 GW<sub>th</sub> reactor core of Kalinin Nuclear Power Plant (KNPP). That allows operating an enormous neutrino flux greater than  $5 \cdot 10^{13}$  per cm<sup>2</sup> per second. The available place for the measurement is located just under the reactor, which provides about 50 m w.e. shielding from cosmic rays. Low threshold germanium diodes are used for the detection of neutrino via its scattering on germanium nucleus. A low background environment including passive shielding and active  $\mu$ -veto is placed around the detectors helping to reduce the background level. For the confirmation of signal, the experiment is using differential type of measurements and a number of experimental techniques. Energy spectra obtained with working and stopped reactor are compared. Apart from this, a movable platform for the experimental setup was specially constructed. It allows to perform measurements at different distances (from about 10 to 12.5 m) from the reactor and change the neutrino flux. This also helps to decrease the systematic uncertainties in a comparison with just analysis spectra with reactor OFF and ON. In the vGEN experiment, we are using low background germanium detectors with a small point contacts made specially for investigations at a very low energy. The experimental energy hardware thresholds are about 200 eV that allows exploring the most important low energy region. Several low-background detectors with a mass more than 1 kg each are used. The sensitivity of the vGEN experiment with new detectors with higher masses and lower threshold in comparison with previous projects will be significantly improved. We are planning to increase a total detector mass up to about 5.5 kg, thus the sensitivity for the magnetic moment of the neutrino would be about  $(5-9) \cdot 10^{-12} \mu_B$  after several years of data taking.

## STATE-OF-THE-ART OF THE INVESTIGATIONS

Coherent elastic neutrino-nucleus scattering on matter is well allowed in the Standard Model and was predicted already in 1974 [1], [2]. Due to the small momentum transfer  $Q$  neutrino interacts simultaneously with all nucleons and its cross section is enhanced by several orders of magnitude in comparison with other neutrino interactions. While being conceptually highly interesting and allowing measurements of electroweak observables at low momentum transfer, the process is also of phenomenological importance for future dark matter direct detection experiments [4]. Moreover, it provides a precision test of neutrino interactions in the Standard Model and strong constraints on new physics related to neutrinos and may hold the potential to probe new neutrino physics [5]. A technology of detection of neutrinos via coherent scattering would also help to develop neutrino based applied research in future (for example, non-intrusive monitoring of nuclear reactors). Any detection of recoil nuclei due to the coherent neutrino scattering is an extremely challenging task mainly due to a tiny energy transfer from neutrino to the nucleus. Often only part of deposited energy can be detected. For example, in germanium detector a typical deposited energy from reactor neutrino is less than 600 eV. The search for CEvNS is performed by a lot of different experiments using: superconducting detectors, noble liquids, inorganic scintillators and others.

Till now only the COHERENT collaboration claimed that they have observed CEvNS [6], [7]. Positive result was obtained with help of CsI and liquid argon detectors. However, the results were obtained with relatively high energy neutrinos from accelerator (30-50 MeV), close to the coherency limit. Thus, more precise investigations of low energy neutrinos scattering required to extend our knowledge to the region of the true coherency. Nuclear reactor are one the most powerful sources of neutrino on the Earth. The energy of reactor neutrino is below  $\sim 10$  MeV, so the coherency conditions are fully satisfied. Since nuclear reactor also are one of the most powerful sources of neutrino on the Earth, many experiments are trying to search for the CEvNS with help of reactor neutrino.

There are several approaches to detect CEvNS from such neutrinos. One approach is to use a new high purity germanium detectors with very good energy resolution and low energy threshold. In recent years, modern developments in HPGe point contact detectors greatly improve its performance, allowing reaching energy threshold of below 200 eV, which was not achievable before. Therefore, there are several project currently running with such experimental techniques:  $\nu$ GEN [8], CONUS [9] and TEXONO [10] experiments. To decrease background level, detectors surrounded by passive and active shielding. The experimental setups are located close to reactor core of nuclear power plants, whose produce big amount of reactor antineutrino. The thermal power of reactors cores uses by mentioned experiments are 3.1 GW, 3.9 GW and 2.9 GW respectively. The distances to the reactor cores are about 10.5 m, 17 m, 28 m respectively. This gives a significant advantage to the  $\nu$ GEN project – the neutrino flux is more than two times higher than at the CONUS location and more than seven times than at TEXONO. Another important advantage of the  $\nu$ GEN project is a lifting platform, which allows moving experimental setup away from the reactor core, changing the neutrino flux. That is why information about neutrino flux can be taken not only from the comparison between spectra taken with reactor ON and OFF, but also from measurements at different distances from the reactor core. Since background level may change during the reactor stoppage, such kind of measurements are very important to reduce systematic error and help to prove that visible excess is not coming from background fluctuation. In addition to mentioned experiments there are many other projects searching for the CEvNS are currently running or constructing: CONNIE [11], RED-100 [12], MINER [13], NUCLEUS [14], RICOCHET [15] and many others. They use various experimental approaches, many of them take experience obtained in dark matter

experiments, where a very good energy threshold and low background levels has been obtained. However, none of them is observed CEvNS yet.

Another fundamental investigation within vGEN project is the search of neutrino magnetic moment (NMM). In the Minimum Extended Standard Model, the NMM can be expressed in terms of the neutrino mass  $m_\nu$ :

$$\mu_\nu = \frac{3eG_F}{8\pi^2\sqrt{2}} \cdot m_\nu \approx 3 \cdot 10^{-19} \mu_B \cdot \frac{m_\nu}{1eV},$$

where  $\mu_B$  is the Bohr magneton ( $\mu_B = e \cdot h / 2m_e$ ). The review on electromagnetic properties and interactions of neutrinos can be found in [16]. There are several different approaches to search the magnetic moment of the neutrino. One of approaches is to use data from solar neutrino experiments. The BOREXINO experiment obtained a best limit on an effective magnetic moment of neutrino of  $\mu_\nu^{eff} \leq 2.8 \cdot 10^{-11} \mu_B$  [17]. This limit has been set using constraints on the sum of the solar neutrino fluxes implied by the radiochemical gallium experiments. The image about the value of NMM can be obtained by the stellar parameters analysis on the last stage of their evolution when the neutrino fluxes carry out almost all the energy that the stars lose. From such parameter estimation like He star mass at the outburst moment, luminosity of white dwarfs and the energy spectrum of neutrino from supernova explosion one can get the limit  $\mu_\nu \leq (0.01 \div 0.1) \cdot 10^{-10} \mu_B$  [18]. The results are model dependent. That is why it is very important to increase the sensitivity of the present laboratory measurements of NMM as it could check the hypothesis about the existence of anomaly huge magnetic moment that goes out of the framework of Standard Model. The measurements that are carried out with the GEMMA-I spectrometer [19], [20], [21] using High Purity germanium detectors at the 3 GW<sub>th</sub> reactor of Kalinin Nuclear Power Plant (KNPP) give the present world best upper limit on MMN at the level of  $2.9 \cdot 10^{-11} \mu_B$ . Using passive and active methods of the background suppression in GEMMA-I experiment it was possible to achieve background level at the low energy region of  $\sim 2.5$  cts/(keV·kg·day)<sup>-1</sup>. The effective energy threshold was about 2.8 keV.

The aim of the present project is to construct a spectrometer with better experimental parameters to be more sensitive to the expected effect. Several serious improvements were considered to increase the level of sensitivity of GEMMA-I. The experiment is now located in another experimental room, which is located closer to the reactor core. The distance to the reactor core is only 10 m. This allows to double a flux that was in GEMMA-I. The value of the neutrino flux is more than  $5 \cdot 10^{13}$  ν/(s·cm<sup>2</sup>) – the highest value in the field. Moreover, the location in the experimental room under the reactor core provides of about 50 m w.e. of overburden serving as a good shielding against cosmic radiation. The new room where the experiment take place is not connected to the reactor containment, so the concentration of radioactive noble gases will be greatly reduced and that will allow to avoid problems with <sup>133</sup>Xe observed in GEMMA-I. The room also has no contamination of <sup>137</sup>Cs and <sup>60</sup>Co isotopes and temperature/humidity conditions are much better stabilized. Thus, we are planning to improve the background index that was in GEMMA-I experiment. Another improvement is connected with energy threshold of germanium detectors. In vGEN we are using detectors with a resolution of about 80 eV (FWHM), thus it is the effective threshold would be below 250 eV. The total detector mass would be about 5.5 kg, thus the sensitivity of the magnetic moment of the neutrino would be about  $(5-9) \cdot 10^{-12} \mu_B$  after several years of data taking. The vGeN HPGe detectors were tested in the LSM laboratory in a low-background passive shield made of copper and lead. The achieved background level was about 1 cts/(keV·kg·day)<sup>-1</sup>. The effective energy threshold of about 250 eV has been obtained in our test measurements. This would open up the possibility to make fundamental tests of the neutrino properties [5].

- [1] D.Z. Freedman, Phys. Rev. D 9 (1974) 1389.
- [2] A. Drukier and L. Stodolsky, Phys. Rev. D 30 (1984) 2295.
- [3] A. J. Anderson, et al., Phys. Rev., D84:013008, (2011).
- [4] J. Billard, L. Strigari, and E. Figueroa-Feliciano, Phys. Rev. D89, 023524 (2014).
- [5] Lindner, M., Rodejohann, W. & Xu, XJ. J. High Energ. Phys. (2017) 2017: 97.
- [6] D. Akimov et al., Science Vol. 357, Issue 6356, pp. 1123-1126 (2017).
- [7] D. Akimov et al., <https://arxiv.org/pdf/2003.10630.pdf>
- [8] V. Belov et al., 2015 JINST 10 P12011.
- [9] J. Hakenmüller et al., Eur.Phys.J.C 79 (2019) 8, 699
- [10] A.Sonay et al., Phys. Rev. C 98, 024602 (2018)
- [11] A. Aguilar-Arevalo et al 2016 J. Phys.: Conf. Ser. 761 012057
- [12] D. Y. Akimov et al., J. Phys. Conf. Ser. 675 no. 1, (2016) 012016.
- [13] G. Agnolet et al., Nucl. Instrum. Meth. A853 (2017) 53–60.
- [14] J. Rothe et al., J Low Temp Phys 199, 433–440 (2020).
- [15] J. Billard, Journal of Physics G: Nuclear and Particle Physics. 44. 10 (2016).
- [16] C.Giunti, A.Studenikin, Rev. Mod. Phys. 87 (2015) 531.
- [17] M. Agostini et al., Phys. Rev. D 96, 091103 (2017).
- [18] G.G. Raffelt, Phys. Rep. 320, 319 (1999); M. Fukugita, preprint Yukawa Institute Kyoto UITP/K-1086 (1994), “Neutrinos in Cosmology and Astrophysics”.
- [19] Beda A. G., et al., // Phys. At. Nucl. 2007. V.70. P.1873;
- [20] Beda A. G., et al.,// Phys. At. Nucl. 1998. V.61. P.66.
- [21] Beda A. G. et al. // Phys. At. Nucl. 2004. V.67. P.1948; hep-ex/9706004.

## DESCRIPTION OF THE PROPOSED RESEARCH

The vGEN experiment is investigating the fundamental properties of the neutrino using HPGe detectors placed in a close vicinity of the powerful nuclear reactor. The collaboration consists of scientists from JINR (Dubna) and ITEP (Moscow). Mainly it focused on the searches of NMM and CEvNS. However, some other scientific directions are also considered.

A laboratory measurement of the NMM is based on its contribution to the  $\nu$ -e scattering. For non-zero NMM, the  $\nu$ -e differential cross section is a sum of weak interaction cross section ( $d\sigma^W/dT$ ) and electromagnetic one ( $d\sigma^{EM}/dT$ ):

$$d\sigma^W/dT = G_F^2 \cdot (m_e/2\pi) \cdot [4x^4 + (1 + 2x^2)^2 \cdot (1 - T/E)^2 - 2x^2(1 + x^2) m_e T/E^2],$$

$$d\sigma^{EM}/dT = \pi r_0^2 (\mu_\nu / \mu_B)^2 (1/T - 1/E),$$

where  $E$  is the incident neutrino energy,  $T$  is the electron recoil energy,  $x^2 = \sin^2 \theta_W \approx 0.238$  is a Weinberg parameter and  $r_0$  is a classical electron radius ( $\pi r_0^2 = 2.495 \times 10^{-25} \text{ cm}^2$ ). One can see that at low recoil energy ( $T \ll E_\nu$ ) the value of  $d\sigma^W/dT$  becomes almost constant while  $d\sigma^{EM}/dT$  increases as  $T^{-1}$ . It becomes evident that the lower detector threshold is the more considerable increase in the NMM effect with respect to the weak irremovable contribution we can obtain.

The basic challenge of the experiment is to decrease the level of background for shallow setup down to the level  $0.5 \div 1 \text{ cts}/(\text{keV} \cdot \text{kg} \cdot \text{day})$ , comparable with the background achieved for deep underground setups. Taking into account this goal, we have chosen the construction of low background setup including an active shielding, which can provide maximum suppression of all cosmic ray background components. Various approaches to solution of this problem were analysed during development of the spectrometer. Spectrometers with pure passive shielding and Ge-NaI spectrometers are also considered. The latter option was chosen as it allowed maximum reduction of all background components under condition of strong cosmic radiation.

The detection of low energy neutrinos via coherent neutrino scattering on a nuclear target is well allowed in the Standard Model and its cross section is enhanced by a several orders of magnitude, being proportional to the number of nuclear target neutrons squared  $N^2$ . For spin-zero nucleon mass  $M$  the differential cross section can be expressed as:

$$\frac{d\sigma}{dT} = \frac{G_F^2}{4\pi} \cdot Q_w^2 M \left[ 1 - \frac{MT}{2E_\nu^2} \right] F^2(Q^2)$$

Here,  $Q$  is the transferred momentum,  $Q^2 = 2E_\nu^2 (1 - \cos \theta)$ ,  $\theta$  is the scattering angle,  $G_F$  is Fermi constant and  $F(Q^2)$  is the elastic nuclear form-factor, which strongly vanishes out the coherent effect with  $Q$  increase ( $F(Q^2) \propto e^{-R^2 Q^2/6}$ ),  $R$  is the nucleus radius). The large coherent scattering enhancement of the cross-section results in expected nuclear recoil rates to be at the level of tens events per kilogram of matter per day for antineutrinos produced by a typical industrial reactor and a detector placed in  $\sim 10 \text{ m}$  from the reactor core. As a result one can significantly reduce the size and mass of the relevant neutrino detector. Therefore, developing the technology for detection of neutrinos via the coherent scattering is one of the priorities for neutrino physics and would help to develop neutrino based applied research in future (for example, non-intrusive monitoring of nuclear reactors). Any detection of recoiled nuclei due to the coherent neutrino scattering is an extremely challenging task mainly due to a tiny energy transfer from neutrino to the nucleus. The recoil energy for Ge nuclei from reactor antineutrinos is  $\lesssim 3 \text{ keV}$ . Only a small fraction (about  $\sim 20\%$ ) of this kinetic energy of the recoil nucleus is converted into energy of ionizing radiation, i.e. detected ionization will be only  $\lesssim 600 \text{ eV}$ .

Reactor neutrinos are referred because among all artificial neutrino sources nuclear reactors provide the largest (anti)neutrino flux up to about  $10 \text{ MeV}$ , thus reactor neutrinos



are able to interact coherently with atomic nuclei. We can place our experimental setup at the distance of about 10 m from the 3 GW<sub>th</sub> reactor's core. The neutrino flux at this place is up to about  $5 \cdot 10^{13}$  neutrinos per sec per cm<sup>2</sup>. This is the highest flux available among the existing experiments. The scheme of the reactor is shown in Fig.1, left.

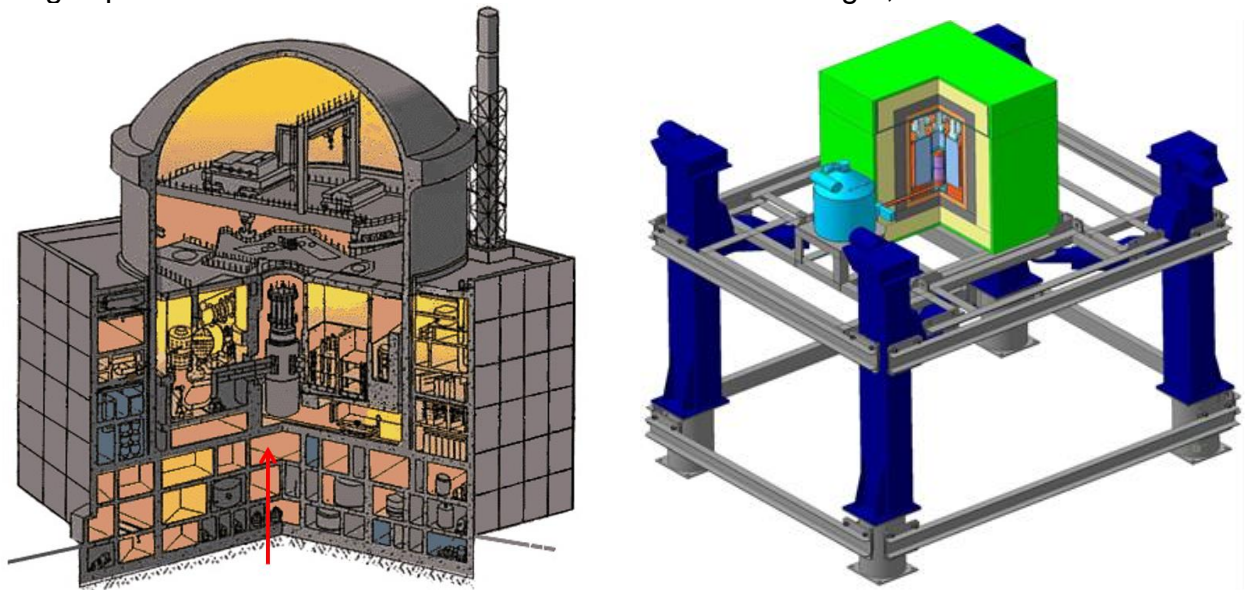
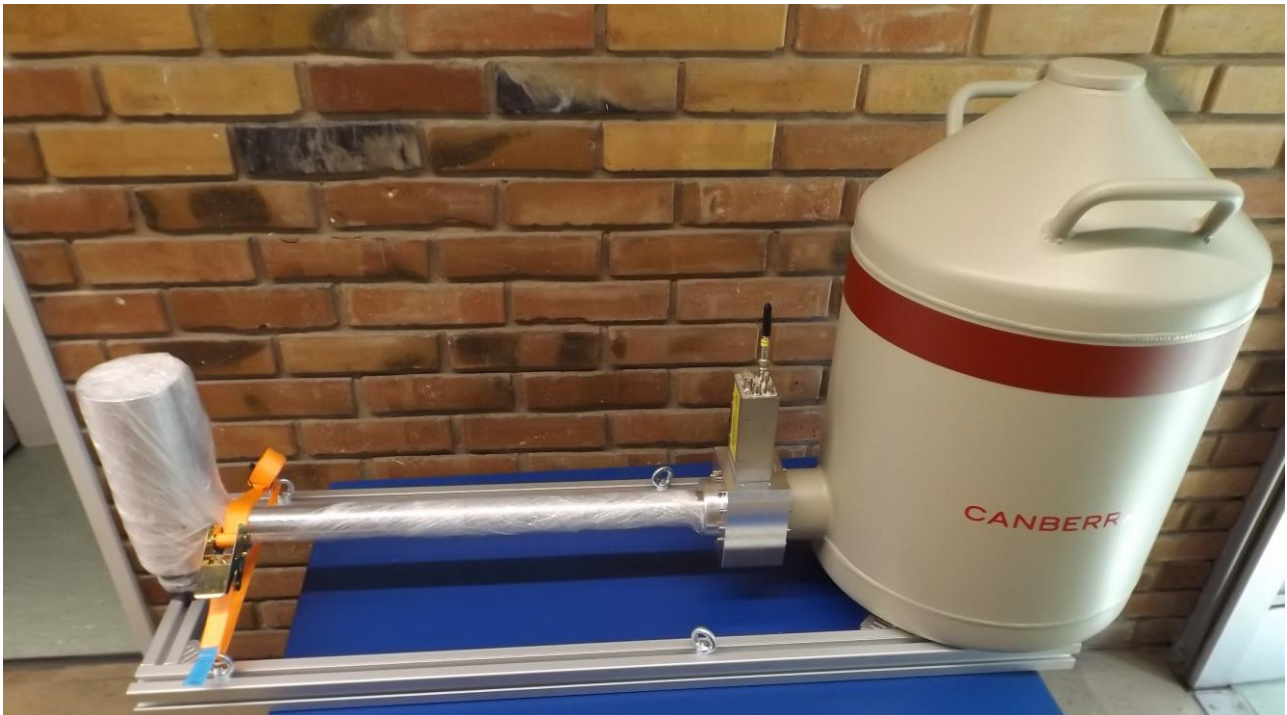

**Figure 1.** Left: the scheme of the reactor unit #3 at KNPP. Arrow indicates the location of the room where experimental setup is being constructed. Right: the scheme of the spectrometer placed on the lifting mechanism.

Experimental setup is located under the reactor core #3. Constructing materials serve as shielding against cosmic radiation (50 m w.e.), so the cosmic muon flux is reduced by a factor  $\sim 6$ , the hadronic component of the flux is almost eliminated. The expected number of events depends on neutrino energy spectrum and flux, detector mass and duration of measurements. Number of expected event would be compared with the background expectations. To prove that observed excess is caused by neutrino several methods of analysis will be used. The first is the comparison between the count rates during reactor ON/OFF regimes and comparison with the background predictions. Second method is based on the idea of changing the neutrino flux by moving experimental setup towards and away from the reactor core. For this purpose a special tool has been developed and installed in the experimental room. The scheme of experimental setup and lifting mechanism is shown on Fig.1, right.

To achieve the desired goal of coherent neutrino detection in the  $\nu$ GEN experiment we use four low background HPGe detectors. The detectors were specially produced for our project in a collaboration with MIRION (CANBERRA, Lingosheim). The masses of detectors are about 1 and 1.5 kg. The total mass of the detectors is about 5.5 kg. Detectors are specially produced from low radioactive materials. Cryostat was made from low background aluminum. The cosmogenic activation was reduced by special transportation and reduced amount of irradiation time above ground. Two types of the cooling system is used: the Dewar filled with liquid nitrogen and electronic cooling with CP5+ cooling system. The photo of detectors are shown on Fig.2 and Fig.3. Before exploitation of the detector, we performed a low background test at deep underground laboratory LSM (Modane, France). With help of only passive shielding we observed that background index (BI) in the energy region between 30-40 keV is  $1.14 \pm 0.05$  cts/(keV·kg·yr). At the low energy region from 500 eV to 1 keV the BI was  $18.6 \pm 0.9$  cts/(keV·kg·yr). These values are compatible to background index obtained in dark matter

experiments with germanium detectors. It is necessary to note that all these results obtain with not ideal shielding conditions and simple electronics.



**Figure 2.** Photo of one HPGe point contact vGeN detectors.

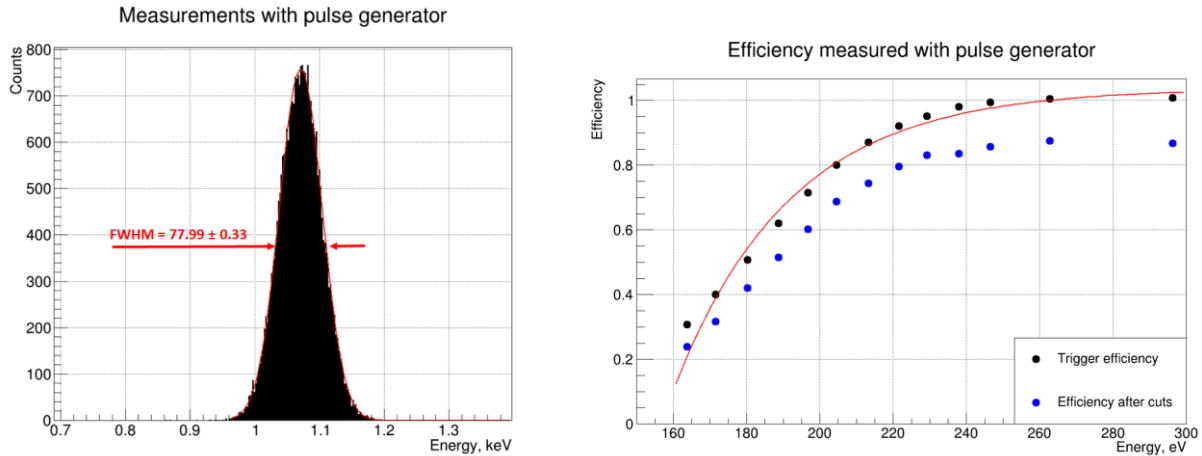

**Figure 3.** Photo of one HPGe point contact vGeN detectors with electric cooling.

It should be still possible to improve the current background index, especially taking into account the fact that all visible lines are coming from cosmogenic activation and decreases in time.

The further, more sophisticated tests at JINR with new electronics showed possibility to achieve good energy resolution and low threshold. Signals from germanium detector are taken by means of real time ADC. The noise events are being suppressed by comparing signals reconstructed with different shaping times of amplifiers. Periodical noise is suppressed by the time cut. The calibration is performed with a help of natural radioactivity and pulse generator. The energy resolution obtained with a pulse generator with the first detector is  $77.99 \pm 0.33$  eV (FWHM) (see Fig.3 left). Measurements of the

efficiency of signal detections with help of the pulse generator showed that detector is acquiring of about 75% signals with energy of 200 eV. This is a huge improvement in a comparison to GEMMA-I where effective threshold was about 2.8 keV.



**Figure 3.** Left: part of the energy spectra obtained with measurements of HPGe detector with pulse generator. Right: efficiency of detection measured with help of a pulse generator.

We started installation of the first  $\nu$ GEN detector at KNPP in the end of 2019. The experimental conditions at power station are not well suited to experimental data taking. Therefore, it is big challenge difficulties to obtain the same detector’s performance and background index as at the laboratory conditions. The scheme of the shielding and a photo of the experimental setup are shown at Fig.4.

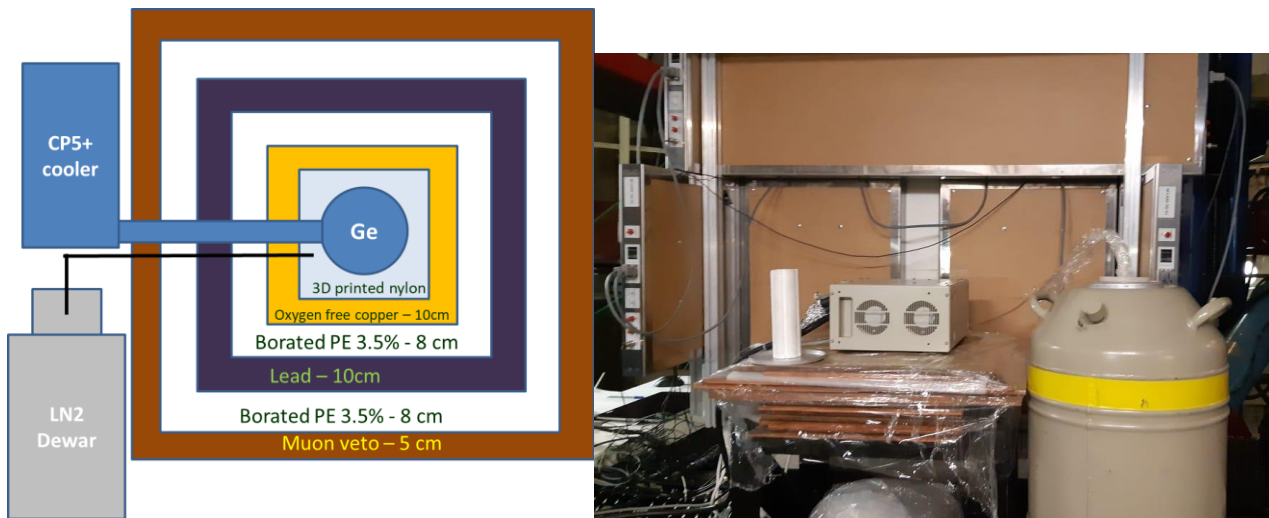

**Figure 4.** Left: scheme of the shielding used at KNPP. Right: photo of the experimental setup at KNPP.

The inner part of the shielding is a specially produced 3D printed nylon, which displace air away from the detector, decreasing the amount of radon inside the shielding. Further layers are 10 cm of oxygen-free copper, 8 cm of 3.5% borated polyethylene, 10 cm of lead another 8 cm of 3.5% borated polyethylene and active muon veto. The energy spectrum obtained in a first measurement at KNPP is shown in Fig.5. The obtained background index is slightly higher than it was at underground laboratory, but we expect some improvements after decay of cosmogenic isotopes and further optimization of electronics and muon veto, which is not in a final design yet. In addition, we have possibility to use inner veto made of NaI scintillator to further reduce background coming from contamination of materials close to the detector.

Part of the spectrum of germanium detector, run 6 & 7

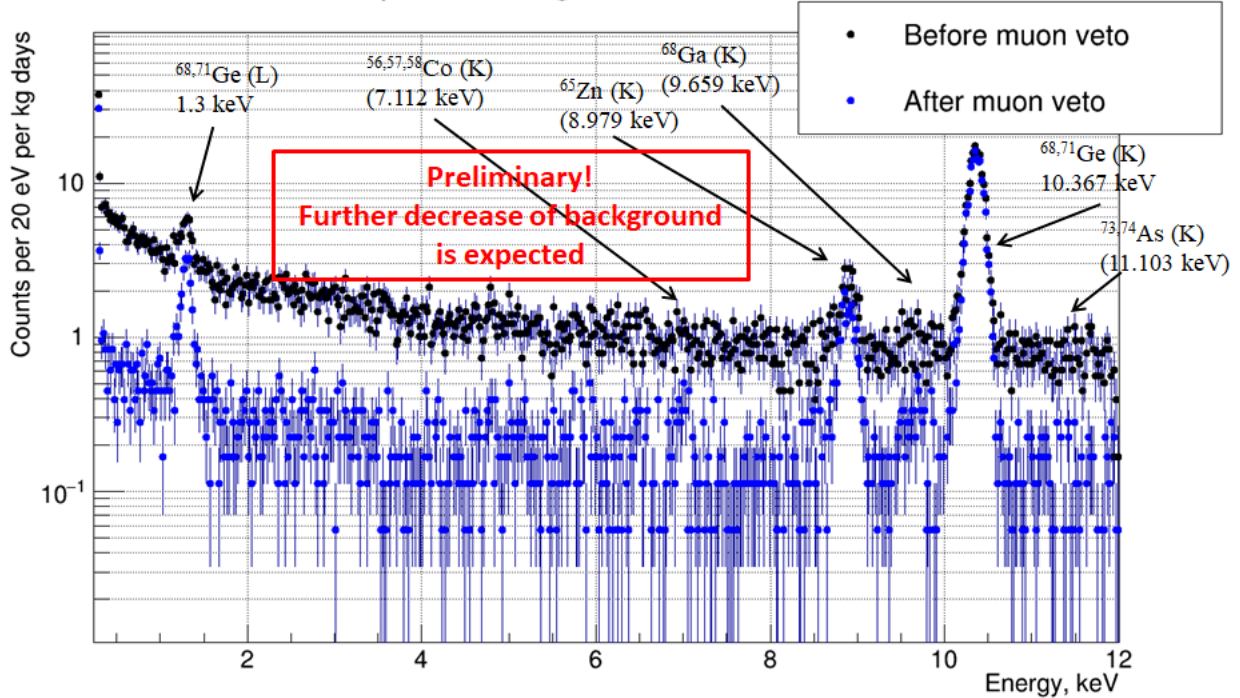

**Figure 5.** Part of the experimental spectrum taken with the first detector at KNPP. Further decrease of the background is expected due to decay of cosmogenic isotopes and optimization of muon veto.

We are planning to continue implementation of this project and take measurements to search for the CEvNS and NMM with the current experimental setup. The next stoppage of the reactor is scheduled in March 2020, so until this time we have data with reactor OFF. Therefore, this gives us the possibility to compare spectra taken with the reactor ON and OFF. At the same time, we are planning to increase the sensitivity of the experiment by improving the background level, by lowering energy threshold and by increasing a total mass of the detectors. The sensitivity to magnetic moment of the neutrino is expected to be about  $(5-9) \cdot 10^{-12} \mu\text{B}$  after several years of data taking. To perform such long-term measurements at KNPP we need to guarantee a stable performance of the detectors. During our first investigations, it was found that vacuum level inside the cryostat is decreasing after several months of measurements. Three out of four produced detectors are sent to MIRION for the warranty repair, the fourth one would be periodically pumped at KNPP. We also plan to perform other investigations to guarantee stable data taking at KNPP. At the same time, new productions allowed to further improve detector energy resolution and threshold, so a new detector with ultimate low energy threshold is planned to be developed and produced to further sensitivity increase.

Thus, the project vGEN is the continuation of predecessor projects GEMMA. Mostly, it is performed by physicists from DLNP (JINR, Dubna) with a collaboration with ITEP (Moscow) and MEPHI (Moscow). By previous steps, it was demonstrated that our group is able to perform modern investigations with HPGe detectors achieving very low background level on a shallow depth. The limit on a magnetic moment of the neutrino obtained in the GEMMA-I experiment is the best in the world so far beyond the terrestrial experiments. We are going to continue our studies and improve our knowledge on the neutrino parameters.

## RESULTS FROM THE PREVIOUS INVESTIGATIONS

Investigation at KNPP by JINR group has a long successful history. Fig.6 shows scheme of GEMMA-I spectrometer constricted at KNPP.

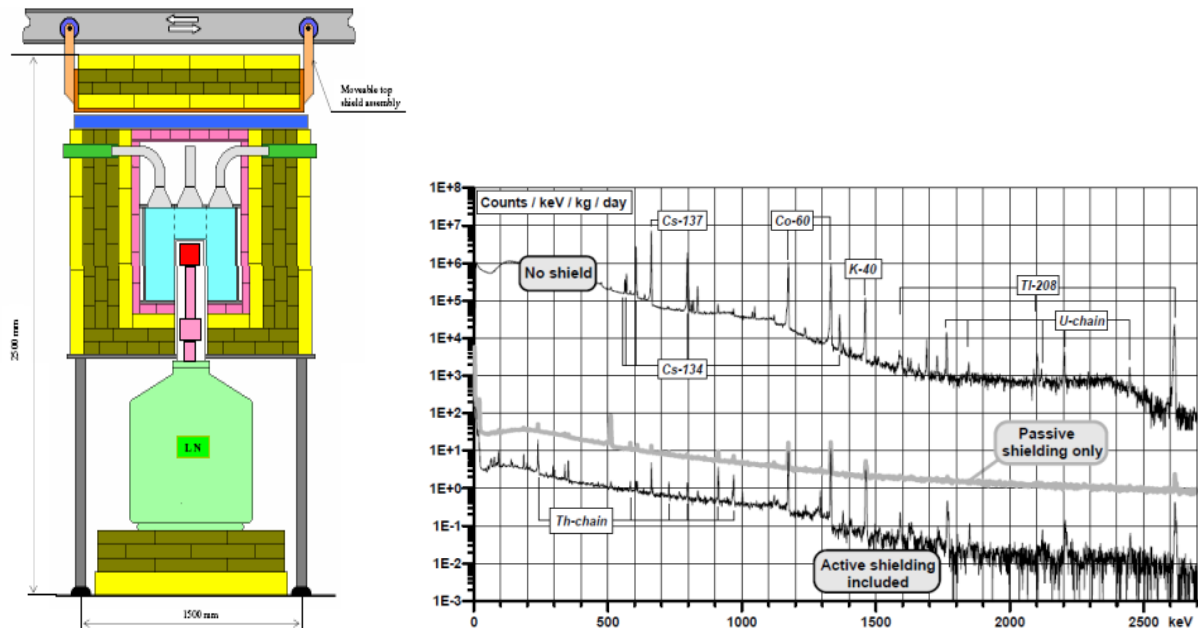

**Figure 6:** Left: scheme of GEMMA-I spectrometer. Right: Gamma-spectra measured at the detector site under different shielding conditions.

The experimental spectra obtained in this project are shown on Fig.6, right. The background level of about  $2.5 \text{ counts}/(\text{keV}\cdot\text{kg}\cdot\text{day})^{-1}$  has been achieved with the GEMMA-I experiment. It was possible to set up the world best limit on a MMN of  $< 2.9 \cdot 10^{-11} \mu_B$  after about four years of data taking (see Fig. 7)

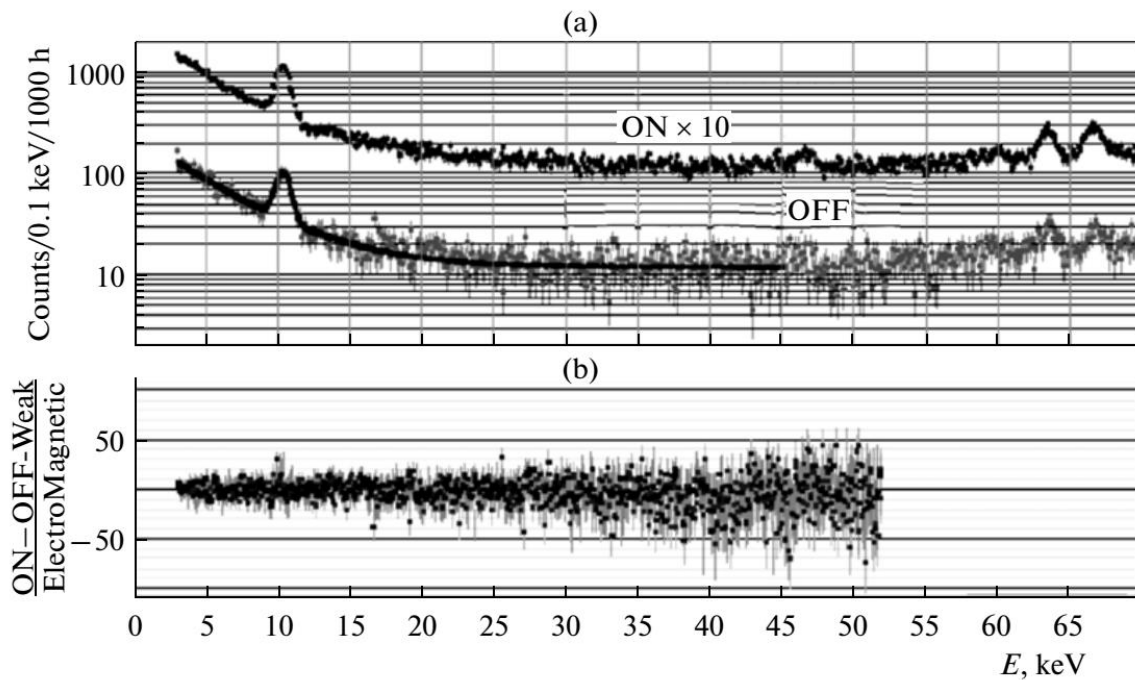

**Figure 7.** Fragments of the experimental ON and OFF spectra (a) and their difference normalized by the electromagnetic cross section (b)

As the limit of sensitivity for GEMMA-I spectrometer reached it was decided to upgrade it to GEMMA-II with better experimental parameters. Two HPGe detectors with the total mass of 6 kg were used for the project. This mass is about four times more than for the GEMMA-I spectrometer. However, a significant contamination of the components of the detectors was found after the production. This does not allow achieving the desired background level in GEMMA-II. During our investigations, we screened of about 50 components and found the source of the contamination for GEMMA-II project. Results of these investigation was taken into account in further projects.

Last years, we were focused on development of the new spectrometer with the projects vGEN and GEMMA-III, which now joined their activities together. The main efforts are connected to improve sensitivity of the detector to weak signals from the neutrino scattering by decreasing of the detector's resolution and threshold. New detectors with much better energy resolution and threshold were tested. Many efforts are performed to suppress the level of the noise signals and discriminate those from the physical events. The example of the analysis using two different amplifiers with different shaping times are shown on Fig.8 left. In addition, we found significant improvement of the energy resolution and threshold by using averaging of the two output signals from preamplifier (see Fig.8, right).

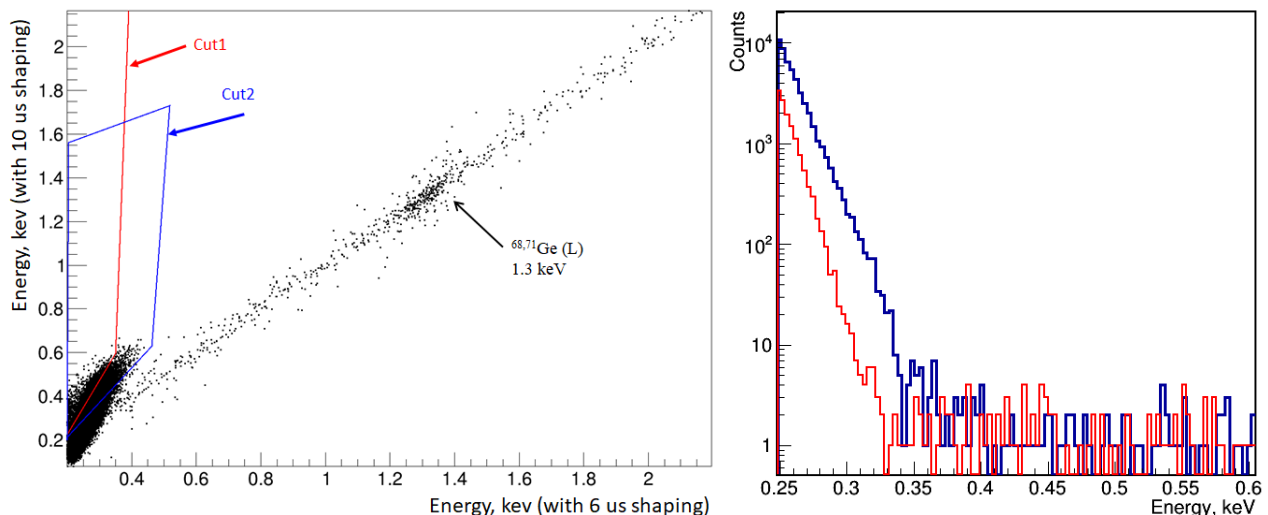

**Figure 8.** Left: an example of the Fourier analysis made with different shaping times. Right: improvement of energy threshold with help of two output of preamplifiers. Blue spectrum taken from one output of preamplifier, red one after averaging of the signals from two outputs.

All such technique allows to suppress the noise signals significantly and thus improve the energy threshold. We are continuously developing other techniques to improve the performance of the detectors. Thus, the significant improvements of the detector performance is obtained in respect with our previous project. It allows to significantly decrease energy threshold and reduce amount of noise events in the region of interests. The further improvements are plans to implement to improve energy threshold and background level. All such experience, methods and the materials from previous experiments is using for vGEN project.

## PUBLICATIONS AND REPORTS

- [1] Beda A. G., Brudanin V. B., Demidova E. V., Vylov Ts., Gavrilov M. G., Egorov V. G., Starostin A. S. and Shirchenko M. V. // Phys. At. Nucl. 2007. V.70. P.1873; hep-ex/0705.4576.
- [2] Beda A. G. et al. // Phys. At. Nucl. 2004. V.67. P.1948; hep-ex/9706004.
- [3] Beda A. G. et al. // Advances in High Energy Physics V.2012 (2012), Article ID 350150, 12 pages doi:10.1155/2012/350150
- [4] Alekseev I. et. al. // arXiv:1305.3350, 2013
- [5] A. Beda et al. GEMMA experiment: three years of the search for the neutrino magnetic moment, Physics of Elementary Particles and Atomic Nuclei Letters, 2010, V.7, №6(162), pp.667-672
- [6] A. Beda et al. GEMMA experiment: the results of neutrino magnetic moment search, Physics of Particles and Nuclei Letters, 2013, V.10, №2, pp.139-143
- [7] A. Beda et al. Experiment GEMMA: Search for the Neutrino Magnetic Moment, 2010, Proceedings of Science, №297
- [8] A. Beda et al. Upper limit on the neutrino magnetic moment from three years of data from the GEMMA spectrometer, 2010, arXiv:1005.2736v1
- [9] A. Beda et al. GEMMA experiment: three years of the search for the neutrino magnetic moment, 2009, arXiv:0906.1926v1
- [10] A. Beda et al. The new result of the neutrino magnetic moment measurement in the GEMMA experiment, proceedings of the 13th Lomonosov Conference on Elementary Particle Physics, 2007
- [11] V. Belov et al., "The vGeN experiment at the Kalinin Nuclear Power Plant", 2015 JINST 10 P12011.

### **Thesis of the participants of the project**

M. Shirchenko, "Investigation of the neutrino properties: helicity and magnetic moment", 2019

### **Contributions on conferences and workshops**

1. D. Medvedev, The International Workshop on Non-Accelerator New Physics (NANPino-2013), Valday, Russia, 2013
2. D. Medvedev, Sixteenth Lomonosov Conference on Elementary Particle Physics, Moscow State University, Moscow, Russia, 2013
3. D. Medvedev, Wilhelm and Else Heraeus-Seminar Exploring the neutrino sky and fundamental particle physics on the Megaton scale, Bad Honnef, Germany, 2013
4. D. Medvedev, Wilhelm and Else Heraeus-Seminar Exploring the neutrino sky and fundamental particle physics on the Megaton scale (poster), Bad Honnef, Germany, 2013
5. D. Medvedev, The International Workshop on Prospects of Particle Physics: "Neutrino Physics and Astrophysics", JINR, INR, Valdai, Russia, 2014
6. D. Medvedev, AYSS 2016, Alushta, Russia, 2016
7. V. Belov, A. Kuznetsov, D. Medvedev, ISAAP, Milan, Italy, 2016
8. V. Belov, A. Kuznetsov, D. Medvedev, ISAAP, Arenzano, Italy, 2017
9. A. Lubashevskiy, ICSSNP 2017, Nalchik, Russia, 2017
10. D. Medvedev, ICSSNP 2017, Nalchik, Russia, 2017
11. A. Lubashevskiy, ISSP 2017, Erice, Italy, 2017
12. A. Lubashevskiy, VLVnT 2018, Dubna, Russia, 2018
13. A. Lubashevskiy, WIN 2019, Bari, Italy, 2019

## ESTIMATION OF HUMAN RESOURCES

The collaboration consists of scientists from JINR and ITEP. The list of the involved people is shown below:

### **JINR (Dubna):**

V.V.Belov, V.B.Brudanin, V.A.Evsenkin, S.A.Evseev, D.V.Filosofov, M.V.Fomina, L.Grubchin, U.B.Gurov, A.Kh.Inoyatov, S.L.Katulina, S.V.Kazarcev, S.P.Kiyanov, A.S.Kuznecov, A.V.Lubashevskiy, D.V.Medvedev, D.V.Ponomarev, D.S.Pushkov, A.V.Salamatin, K.V.Shakhov, Z.Kh.Khukhvatov, V.G.Sandukovsky, M.V.Shirchenko, E.A.Shevchik, S.V.Rozov, I.E.Rozova, V.P.Volnikn, I.V.Zhitnikov, E.A.Yakushev

### **ITEP (Moscow):**

A. G. Beda, A. S. Starostin

Detail information about JINR group human resources:

Name	Category	Responsibilities	Time that each participant will give to the work under the Project in relation to its Full Time Equivalent(FTE)
V.V.Belov	Junior researcher	Muon veto, MC, data taking	0.2
V.B.Brudanin	Head of department	Administrative work, project management	0.1
V.A.Evsenkin	Engineer	Constructions, detector building	0.5
S.A.Evseev	Engineer	Constructions, detector building	0.4
D.V.Filosofov	Head of sector	Calibration sources	0.1
M.V.Fomina	Junior researcher	Muon veto, MC	0.1
L.Grubchin	Leading researcher	Detector development	0.1
U.B.Gurov	Senior engineer	Detector development	0.2
A.Kh.Inoyatov	Head of sector	Spectroscopy measurements	0.1
S.L.Katulina	Senior engineer	Administrative work, materials preparations	0.1
S.V.Kazarcev	Junior researcher	Electronics, data taking	0.1
S.P.Kiyanov	Senior engineer	Data taking at KNPP	0.3
A.S.Kuznecov	Engineer	Data taking, MC	0.1
A.V.Lubashevskiy	Senior Researcher	Data analysis, MC, commissioning and administrative work	0.5
D.V.Medvedev	Researcher	Data analysis, MC	0.7
D.V.Ponomarev	Engineer	Constructions, detectors building, testing. Experiment running.	0.7
D.S.Pushkov	Senior	3D modeling and design of	0.2



	engineer	experimental setup	
A.V.Salamatin	Senior researcher	Electronics	0.1
K.V.Shakhov	Engineer	3D printing, construction	0.1
Z.Kh.Khukhvatov	Junior researcher	MC	0.2
V.G.Sandukovsky	Head of sector	Detector configuration, constructions	0.5
E.A.Shevchik	Senior engineer	Mu-veto, constructions	0.1
M.V.Shirchenko	Senior researcher	Data taking, analysis	0.1
S.V.Rozov	Engineer	Detector building, testing, calibration, running.	0.3
I.E.Rozova	Engineer	Data analysis, constructions	0.5
V.P.Volnikn	Engineer	Computer support	0.1
I.V.Zhitnikov	Junior researcher	Experiment running, data analysis	0.1
E.A.Yakushev	Head of sector	Building, commissioning, running, data analysis	0.2
<b>Total FTE (Engineers): 3.5, Total FTE (Scientific staff): 3.2, Total FTE: 6.7</b>			

## SWOT ANALYSIS

Strengths, Weaknesses, Opportunities, Threat (SWOT) analysis of vGEN project is discussed below.

The investigation of the properties of the neutrino attracts interests of many experimental groups around the Earth. Many scientists put their efforts in this field and the level of competition is very high. Due to this factor, it is possible that somebody can obtain better experimental result than we would do. This is one of the main threats of our project. But nevertheless, this gives a good opportunity to do interesting investigation on the first edge of the neutrino physics. The results obtained in this project may open up the possibility for another fundamental or applied investigations of neutrino properties. For example, searches for the fundamental non-standard neutrino interactions or applied research, like reactor monitoring.

Our group has proved capability to achieve the best experimental results in the world, setting up a best limit on the MMN. The big strengths of our project is the possibility to perform investigations with the enormous antineutrino flux of more than  $5 \cdot 10^{13} \nu / (\text{cm}^2 \cdot \text{s})$ . Moreover, the most dangerous cosmic background in the experimental room is strongly suppressed by the reactor building and various materials inside it. This is very suitable conditions to build an experiment for testing of fundamental properties of neutrino. In comparison to other projects we have possibility to use lifting mechanism that allows us to change the neutrino flux from the reactor by moving the spectrometer away from the core, reducing systematical errors. This is important due to the fact that sought signals typically have a signature similar to background or noise components. Personnel and administration of KNPP greatly supports our activities, however we cannot completely exclude potential difficulties at KNPP due to changes of regulation, rules etc. Therefore, this is a possible weakness of the project.

Our group at DLNP JINR holds huge expertises connected with different low background projects. Our division participates in many big international experiments for dark matter and neutrinoless double beta decay searches. Such interconnection gives us a big advantage of having the modest expertise and access to the recent developments in low background technique. From previous experiment, we have some low-background materials available and they can be used for the construction of a new experiment.

In addition, one of the most important strength of our project is people. The core group of the project is relatively young people, however already with a good experience in the neutrino physics and low-background projects. Many people have experience working for international collaborations. The investigations are leaded by big experts in the field. Therefore, there is good balance between youth and experience in this project.

# Изучение свойств нейтрино с помощью низкофонового германиевого спектрометра $\nu$ GEN

**Авторы из ОИЯИ:** Белов В.В., Бруданин В.Б., Вольных В.П., Грубчин Л., Гуров Ю.Б., Евсенкин В.А., Евсеев С.А., Житников И.В., Зинатулина Д.Р., Иноятов А.Х., Катулина С.Л., Казарцев С.В., Киянов С.П., Кузнецов А.С., Лубашевский А.В., Медведев Д.В., Пономарев Д.В., Пушков Д.С., Саламатин А.В., Розов С.В., Розова И.Е., Сандуковский В.Г., Философов Д.В., Фомина М.В., Шахов К.В., Шевчик Е.А., Ширченко М.В., Шухватов З.Х., Якушев Е.А.

## Аннотация:

Проект  $\nu$ GEN направлен на исследование фундаментальных свойств нейтрино при помощи реакторных нейтрино от энергетического реактора Калининской АЭС (КАЭС). Поиск упругого когерентного рассеяния нейтрино на ядрах вещества осуществляется в данном проекте. Этот процесс до сих пор не был обнаружен для реакторных нейтрино. В случае обнаружения, это откроет возможность поиска Новой физики через поиск нестандартных взаимодействий нейтрино и поиск стерильных нейтрино. Также это откроет возможность для проведения прикладных исследований, таких как мониторинг мощности реакторов. Экспериментальная установка  $\nu$ GEN строится под реактором №3 КАЭС на расстоянии около 10 м от центра активной зоны реактора. Это позволяет оперировать рекордным потоком нейтрино более чем  $5 \cdot 10^{13}$  нейтрино/(см<sup>2</sup>·сек). Специальный подъемный механизм был разработан для движения всей экспериментальной установки по направлению к активной зоне реактора. Это позволяет изменять поток антинейтрино и значительно снижать систематическую ошибку, связанную с неопределенностями в определении уровня фона. Специально разработанные низкороговые, низкофоновые германиевые детекторы используются для регистрации сигнала от нейтрино. С новыми детекторами удалось добиться разрешения в лучшем, чем 80 эВ (FWHM), что позволяет достичь порога измерений лучше, чем 250 эВ. Суммарная масса четырех используемых детекторов составляет 5.5 кг. Для уменьшения количества фоновых событий в области интереса используется специальная система из активной и пассивной защиты от радиоактивного излучения. Кроме когерентного рассеяния нейтрино в проекте осуществляется и поиск магнитного момента нейтрино. Обнаружение его будет обнаружением Новой физики за пределами Стандартной Модели и свидетельствовать Майорановской природе нейтрино. В первой фазе проекта GEMMA-I был установлен лучший в настоящее время предел на величину магнитного момента нейтрино в  $< 2.9 \cdot 10^{-11}$   $\mu$ в. В настоящей фазе планируется увеличить чувствительность к уровню  $(5-9) \cdot 10^{-12}$   $\mu$ в после нескольких лет измерений.

Изучение свойств нейтрино является важной задачей для физики частиц, астрофизики и космологии. Несмотря на то, что нейтрино – одна из самых распространённых частиц во Вселенной, ее детектирование является сложной задачей вследствие крайне слабого взаимодействия этой частицы с веществом. Поэтому, чтобы изучить ее свойства необходим очень сильный источник нейтрино и использование различных методик подавления фоновых событий. Когерентное упругое Рассеяние Нейтрино на ядрах вещества (КРН) – это процесс, предсказанный в рамках Стандартной модели. Однако он еще никогда не был обнаружен для реакторных нейтрино. Детектирование этого процесса является важным тестом Стандартной Модели. Большой интерес к этому процессу вызван еще тем, что с помощью него можно производить поиск нестандартных взаимодействий нейтрино, стерильного нейтрино и других интересных исследований. Однако вследствие низкого сечения рассеяния и малого энерговыделения обнаружение данного эффекта является нетривиальной задачей, требующего использования низкопороговых детекторов и методов по подавлению фоновых событий. Магнитный Момент Нейтрино (ММН) это фундаментальный параметр, исследование которого может привести к результатам, выходящим за рамки Стандартной Модели. Минимально Расширенная Стандартная Модель предсказывает очень малое значение магнитного момента для массивных нейтрино ( $\mu_\nu < 10^{-19} \mu_B$ ), которое не может быть измерено в современных экспериментах. Однако, в большом количестве расширений Стандартной Модели предсказывается, что значение ММН может быть на уровне  $10^{-(10-12)} \mu_B$  для Майорановских нейтрино. Наблюдение значения ММН выше чем  $10^{-14} \mu_B$  будет свидетельствовать об обнаружении физики за пределами Стандартной Модели и о Майорановской природе нейтрино.

$\nu$ GEN это эксперимент, который создается под реактором №3 КАЭС для детектирования вышеперечисленных процессов. Этот эксперимент является эволюцией наших предыдущих проектов GEMMA. На первой фазе проекта GEMMA-I было получено лучшее ограничение на верхний предел ММН в  $< 2.9 \cdot 10^{-11} \mu_B$  (90% CL). Измерения производились с помощью 1.5 кг германиевого детектора, порог измерений составлял около 2.8 кэВ. Используя пассивные и активные методы подавления фона в эксперименте был достигнут уровень фона в низкой области энергий  $\sim 2.5$  отсчет/(кэВ·кг·сут) $^{-1}$ .

В  $\nu$ GEN планируется значительно улучшить чувствительность установки по сравнению с предыдущими проектами. В частности, экспериментальная установка будет находиться на расстоянии около 10 м от 3 ГВт реактора КАЭС. Это позволяет оперировать гигантским потоком нейтрино - свыше  $5 \cdot 10^{13}$  нейтрино на  $\text{см}^2$  в секунду. Более того, экспериментальный зал расположен непосредственно под реактором, что дает хорошую защиту от космического излучения, эквивалентную 50 м в.э. Схема реактора показана на Рис.1, слева.

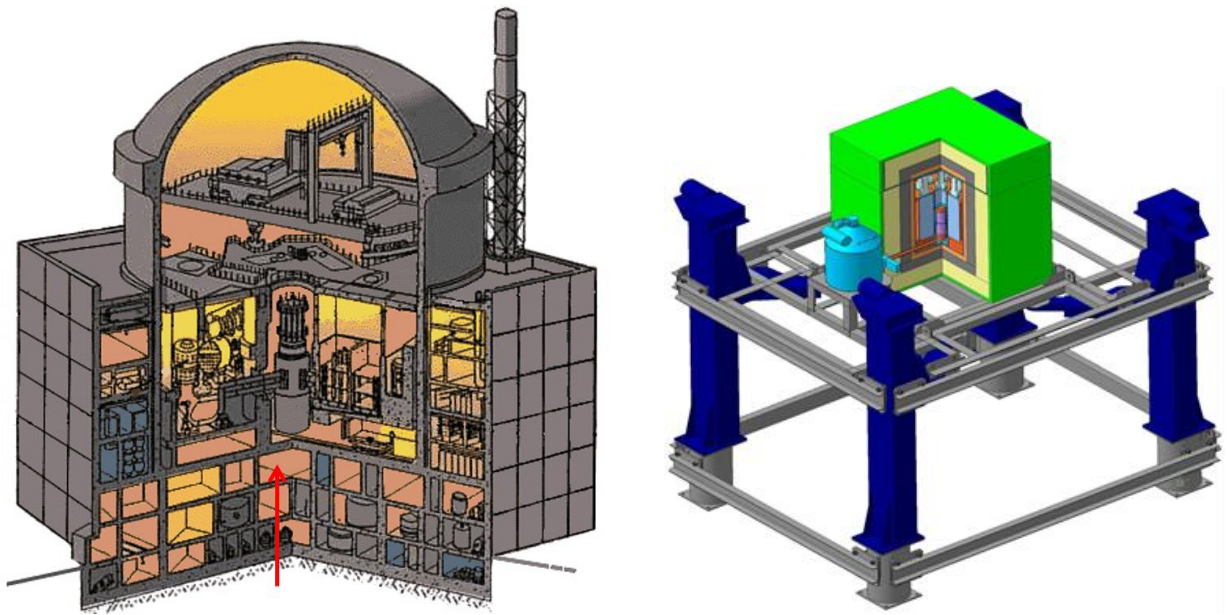

**Рисунок 1. Слева:** схема реактора №3 КАЭС. Стрелкой указан комната, в которой будет находиться экспериментальная установка. **Справа:** схема спектрометра, помещенного на подъемный механизм.

Был изготовлен специальный подъемный механизм, позволяющий передвигать спектрометр по направлению к ядру реактора. Это позволяет значительно изменять поток реакторных нейтрино, и снизить систематические ошибки, вызванные возможными нестабильностями и потоком нейтрино (Рис.1, справа).

Сигнал от нейтрино детектируется с помощью специальных низкофоновых низкороговых германиевых детекторов, произведенных в коллаборации с MIRION (Лингольсхайм, Франция). Были произведены четыре детектора общей массой около 5.5 кг. Энергетическое разрешение одного из детекторов составило  $77.99 \pm 0.33$  эВ (FWHM). Измерения эффективности регистрации событий показали, что эффективность регистрации событий с энергией в 200 эВ составляет примерно 75%. Что является большим шагом по сравнению с экспериментом GEMMA-I, где эффективный порог измерений составлял 2.8 кэВ. Радиоактивная чистота детекторов vGEN была исследована в подземной лаборатории LSM (Модан, Франция) и она удовлетворяет требованиям эксперимента, однако в условиях атомной станции достичь подобных значений гораздо сложнее. Для обеспечения требуемых параметров работы детекторов и уровня радиоактивного фона предприняты специальные усилия. Схема пассивной и активной защиты спектрометра показана на рисунке 2. Внутренняя часть защиты представляет собой специальный нейлон изготовленный на 3D принтере, далее идет 10 см слой меди, 8 см борированного полиэтилена, 10 см свинца и 8 см борированного полиэтилена. Снаружи установлено активное мюонное вето.

Энергетический спектр полученный в первых измерениях на КАЭС показан на рисунке 3. Все наблюдаемые пики в показанном спектре появляются в результате распада космогенных изотопов и уменьшаются с течением времени. Возможно также дальнейшее снижение уровня фона с помощью использования внутреннего NaI сцинтилятора.

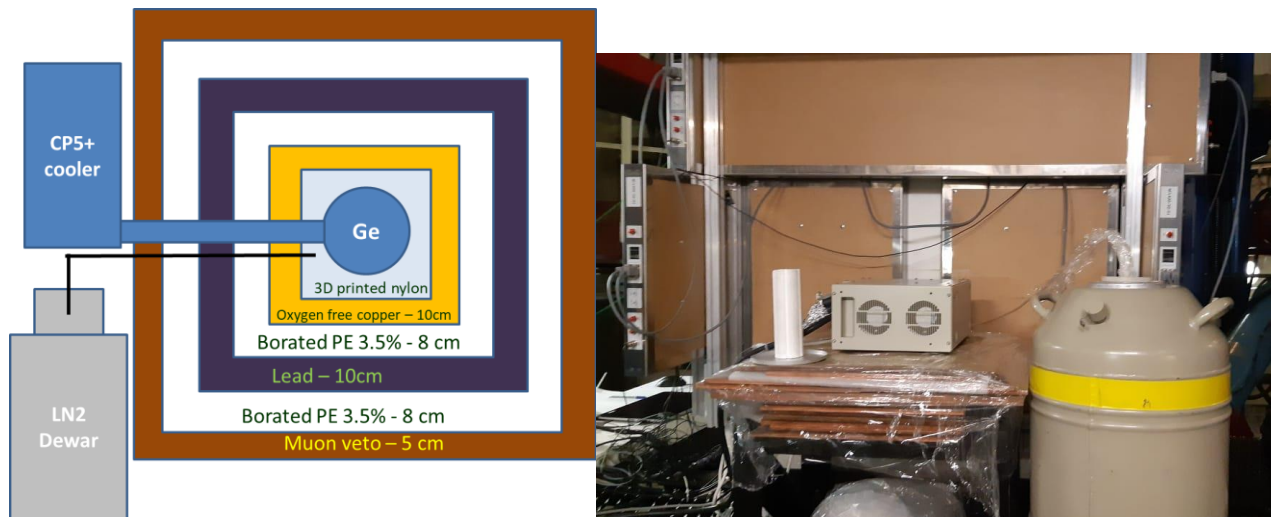

**Рисунок 2.** Слева: схема защиты от радиоактивного излучения используемая на КАЭС. Справа: фото экспериментальной установки на КАЭС.

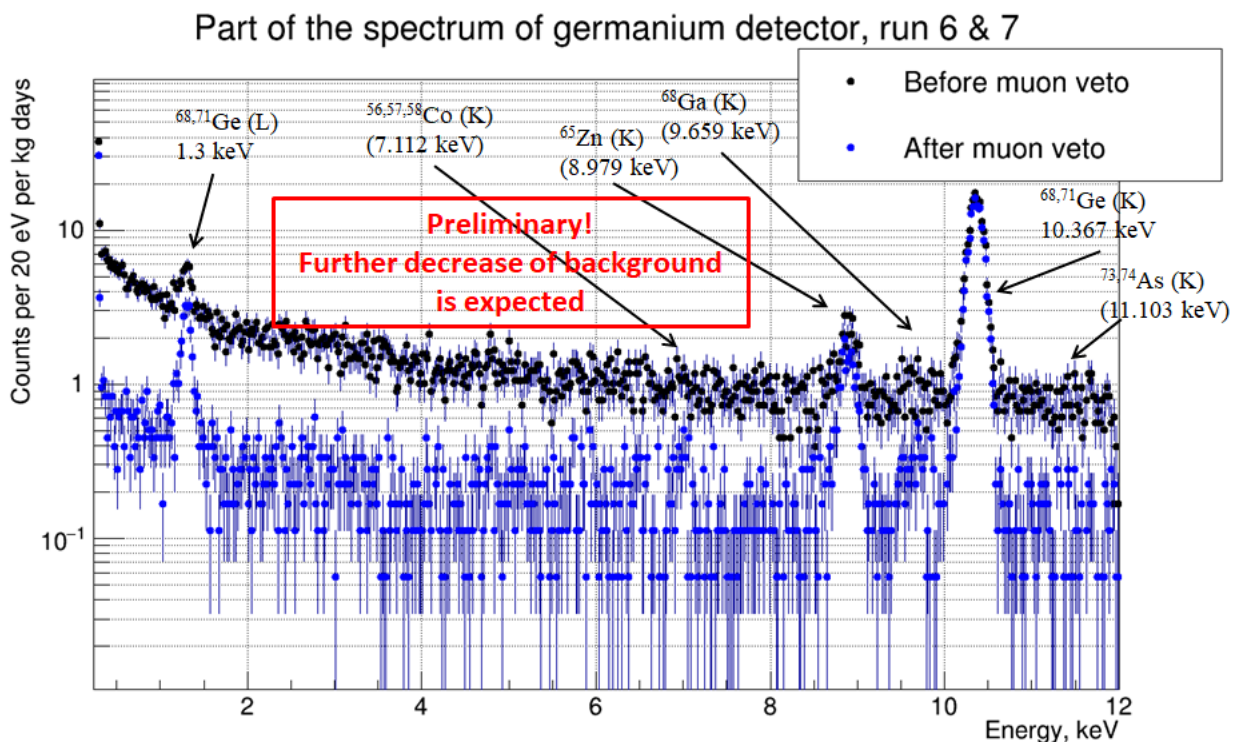

**Рисунок 3.** Часть энергетического спектра, полученного в первых измерениях с одним детектором на КАЭС. Дальнейшее снижение уровня фона ожидается вследствие распада космогенных изотопов и оптимизации защиты.

Проект  $\nu$ GEN является продолжением предыдущих проектов GEMMA. На предыдущих этапах нами была продемонстрирована возможность достижения достаточно низкого уровня фона в надземной лаборатории. Ограничение на MMN полученное в эксперименте GEMMA-I является лучшим современным лабораторным результатом. Мы планируем продолжать данные исследования и получить больше знаний о вышеупомянутых параметрах нейтрино.

Investigation of neutrino properties with  
the low-background germanium spectrometer vGEN

vGEN

CODE OF THEME 03-2-1100-2010/2021

V.V.Belov, V.B.Brudanin, V.A.Evsenkin, V.G.Egorov, Z.H.Hushvatov, D.V. Filosofov,  
M.V.Fomina, N.S.Gorskov, A.H.Inoyatov, S.L.Katulina, S.V.Kazarchev, S.P.Kiyanov,  
A.S.Kuznecov, A.V.Lubashevskiy, D.V.Medvedev, D.V.Ponomarev, D.S.Pushkov,  
A.V.Salamatin, V.G.Sandukovsky, S.V.Rozov, I.E.Rozova, V.P.Volnych, I.V.Zhitnikov,  
E.A.Yakushev, D.R.Zinatulina

Laboratory of Nuclear Problems, JINR

NAMES OF PROJECT LEADERS: V.B.Brudanin

NAME OF PROJECT DEPUTY LEADERS: A.V.Lubashevskiy, E.A.Yakushev

DATE OF SUBMISSION OF PROPOSAL OF PROJECT TO SOD \_\_\_\_\_

DATE OF THE LABORATORY STC \_\_\_\_\_ DOCUMENT NUMBER \_\_\_\_\_

STARTING DATE OF PROJECT January 2022 (FOR EXTENSION OF  
PROJECT — DATE OF ITS FIRST APPROVAL) 07.02.2014

PROJECT ENDORSEMENT LIST

Investigation of neutrino properties with  
the low-background germanium spectrometer vGEN

vGEN

CODE OF THEME 03-2-1100-2010/2021

NAME OF PROJECT LEADER: Viktor Brudanin

APPROVED BY JINR DIRECTOR

---

ENDORSED BY

SIGNATURE

DATE

---

JINR VICE-DIRECTOR

---

CHIEF SCIENTIFIC SECRETARY

---

CHIEF ENGINEER

---

HEAD OF SCIENCE ORGANIZATION DEPARTMENT

---

LABORATORY DIRECTOR

---

LABORATORY CHIEF ENGINEER

---

PROJECT LEADER

---

PROJECT DEPUTY LEADERS

---

ENDORSED

---

RESPECTIVE PAC

---



### Schedule proposal and resources required for the implementation of the Project

#### vGEN

List of parts and devices; Resources; Financial sources		Cost of parts (K US\$), resources needs	Allocation of resources and money			
			1 <sup>st</sup> year	2 <sup>nd</sup> year	3 <sup>rd</sup> year	
Main parts and equipment	1. Cryogenic and vacuum equipment for the detectors. New advance detector.		270	70		200
	2. Materials and equipment for calibration and shielding.		45	35	10	
	3. Electronics NIM		40	30	10	
	4. Electronics VME		40	30	10	
	<b>Total</b>		<b>395</b>	<b>165</b>	<b>30</b>	<b>200</b>
Resources	Norm-hours	DLNP workshop	600	200	200	200
Financial sources	JINR budget	Budget spending	<b>395</b>	<b>165</b>	<b>30</b>	<b>200</b>
	Off-budget sources	Grants; Other sources (these funds are not currently guaranteed)	45	20	15	10

PROJECT LEADER

V.Brudanin

**Estimated expenditures for the Project vGEN**, Investigations of neutrino properties with the low-background germanium spectrometer vGEN

#	Designation for outlays	Total cost	1 year	2 year	3 year
Direct expenses for the project					
1.	Networking	6.0K US\$	2.0	2.0	2.0
2.	DLNP workshop	600 norm-hours	200	200	200
3.	Materials	45.0K US\$	35.0	10.0	0.0
4.	Equipment	350.0K US\$	130.0	20.0	200.0
5.	Expenses for R&D on a contract base	6.0K US\$	2.0	2.0	2.0
6.	Travel expenses, including a) to non-rouble zone countries б) to cities of rouble zone countries	60.0K US\$	20.0	20.0	20.0
			5.0	5	5
			15.0	15.0	15.0
<b>Total</b>		<b>467.0K US\$</b>	<b>189.0KUS\$</b>	<b>54.0KUS\$</b>	<b>224.0K US\$</b>

PROJECT LEADER

LABORATORY DIRECTOR

LABORATORY CHIEF ENGINEER-ECONOMIST

Изучение свойств нейтрино с помощью  
низкофонового германиевого спектрометра vGEN

Проект vGEN

ШИФР ТЕМЫ 03-2-1100-2010/2021

АВТОРЫ ОТ ОИЯИ:

Белов В.В., Бруданин В.Б., Вольных В.П., Грубчин Л., Гуров Ю.Б., Евсенкин В.А.,  
Евсеев С.А., Житников И.В., Зинатулина Д.Р, Инояттов А.Х., Катулина С.Л., Казарцев  
С.В., Киянов С.П., Кузнецов А.С., Лубашевский А.В., Медведев Д.В., Пономарев Д.В.,  
Пушков Д.С., Саламатин А.В., Розов С.В., Розова И.Е., Сандуковский В.Г.,  
Философов Д.В., Фомина М.В., Шахов К.В., Шевчик Е.А., Ширченко М.В., Шухватов  
З.Х., Якушев Е.А.

Объединенный институт ядерных исследований, ЛЯП (Дубна)

РУКОВОДИТЕЛЬ ПРОЕКТА: В.Б. Бруданин.

ЗАМЕСТИТЕЛЕЙ РУКОВОДИТЕЛЯ ПРОЕКТА: А.В.Лубашевский, Е.А.Якушев

ДАТА ПРЕДСТАВЛЕНИЯ ПРОЕКТА В НОО \_\_\_\_\_

ДАТА НТС ЛАБОРАТОРИИ \_\_\_\_\_ НОМЕР ДОКУМЕНТА \_\_\_\_\_

ДАТА НАЧАЛА ПРОЕКТА GEMMA3: январь 2019

(ДАТА ПЕРВОГО УТВЕРЖДЕНИЯ ПРОЕКТА (GEMMA-II) на НТС ЛЯП): 07.02.2014

ЛИСТ СОГЛАСОВАНИЙ ПРОЕКТА

ПОЛНОЕ НАЗВАНИЕ ПРОЕКТА: Изучение свойств нейтрино с помощью  
низкофонового германиевого спектрометра  $\nu$ GEN

УСЛОВНОЕ ОБОЗНАЧЕНИЕ ПРОЕКТА ИЛИ КОЛЛАБОРАЦИИ:  $\nu$ GEN

ШИФР ТЕМЫ 03-2-1100-2010/2021

ФИО РУКОВОДИТЕЛЯ ПРОЕКТА: Бруданин Виктор Борисович

УТВЕРЖДЕН ДИРЕКТОРОМ ОИЯИ

СОГЛАСОВАНО	ПОДПИСЬ	ДАТА
ВИЦЕ-ДИРЕКТОР ОИЯИ		
ГЛАВНЫЙ УЧЕНЫЙ СЕКРЕТАРЬ		
ГЛАВНЫЙ ИНЖЕНЕР		
НАЧАЛЬНИК НОО		
ДИРЕКТОР ЛАБОРАТОРИИ		
ГЛАВНЫЙ ИНЖЕНЕР ЛАБОРАТОРИИ		
РУКОВОДИТЕЛЬ ПРОЕКТА		
ЗАМ. РУКОВОДИТЕЛЯ ПРОЕКТА		
ОДОБРЕН		
ПКК ПО НАПРАВЛЕНИЮ		

**Предлагаемый план-график и необходимые ресурсы для осуществления проекта vGEN**

Наименование узлов и систем установки, ресурсов, источников финансирования		Стоимость узлов (тыс.\$). Потребности в ресурсах	Предложения Лабораторий по распределению финансирования и ресурсов			
			1 год	2 год	3 год	
Основные узлы и оборудование	1.Криогенное и вакуумное оборудования для детекторов. Германиевый детектор.	70.0	70.0		200	
	2. Материалы для калибровок и пассивной защиты.	45.0	35.0	10.0		
	3. Электроника NIM	40.0	30.0	10.0		
	4. Электроника VME	40.0	30.0	10.0		
	Итого	395.0	165.0	30.0	200.0	
Необходимые ресурсы	Нормо-часы	ООЭП ЛЯП	600	200	200	200
Источники финансирования	Бюджет	Затраты из бюджета	395.0	165.0	30.0	200.0
	Внебюджетные средства	Вклады коллаборантов. Средства по грантам. Вклады спонсоров Средства по договорам. Другие источники и т.д.	45.0	20.0	15.0	10.0

Руководитель проекта:

Форма № 29

**Смета затрат по проекту «vGEN»**

№	Наименование статей затрат	Полная стоимость	1 год	2 год	3 год
Прямые затраты на Проект					
1.	Компьютерная связь	6.0 тыс. \$	2.0	2.0	2.0
2.	ООЭП ЛЯП	600 нормо/час	200	200	200
3.	Материалы	45.0 тыс. \$	35.0	10.0	5.0
4.	Оборудование	350.0 тыс. \$	130.0	20.0	200.0
5.	Оплата НИР, выполняемых по договорам	6.0 тыс. \$	2.0	2.0	2.0
6.	Командировочные расходы, в т.ч.	60.0 тыс. \$	20.0	20.0	20.0
	а) в страны нерублевой зоны		5.0	5.0	5.0
	б) в города стран рублевой зоны		15.0	15.0	15.0

**Итого по прямым расходам      467.0 тыс.\$    189.0 тыс.\$ 54.0тыс.\$ 224.0тыс.\$**

**Руководитель Проекта**

**Директор Лаборатории**

**Ведущий инженер-экономист  
Лаборатории**