



BEAM TRANSFER SYSTEMS OF NICA FACILITY: FROM BOOSTER TO NUCLOTRON

*A. Tuzikov¹⁾, O. Anchugov²⁾, A. Bazanov¹⁾, E. Bekhtenev²⁾, O. Belikov²⁾, L. Belova²⁾,
A. Butenko¹⁾, A. Dolgov, A. Fateev¹⁾, A. Galimov¹⁾, V. Karpinsky¹⁾, G. Karpov²⁾,
V. Kiselev²⁾, S. Kolesnikov¹⁾, S. Kostromin¹⁾, A. Krasnov²⁾, A. Kudashkin¹⁾, O. Kunchenko¹⁾,
V. Kuzminykh²⁾, A. Lisitsyn²⁾, I. Meshkov¹⁾, O. Meshkov²⁾, D. Nikiforov¹⁾, I. Okunev²⁾,
A. Pavlenko²⁾, P. Piminov²⁾, A. Rakhimov²⁾, S. Romanov¹⁾, N. Rybakov¹⁾, V. Seleznev¹⁾,
D. Senkov²⁾, S. Shiyankov²⁾, D. Shvedov²⁾, V. Shvetsov¹⁾, A. Sidorin¹⁾, A. Sidorov¹⁾,
S. Sinyatkin²⁾, E. Syresin¹⁾, A. Zhukov²⁾, A. Zhuravlev²⁾,*

1) Joint institute for nuclear research, Dubna

2) Budker Institute of Nuclear Physics, Novosibirsk

Beam transfer from Booster to Nuclotron

Beam Parameters

Ions:	
before stripping station	Au ³¹⁺
after stripping station	Au ⁷⁹⁺
Maximum magnetic rigidity of ions, T m:	
before stripping station	25
after stripping station	10
Ion number	$1.5 \cdot 10^9$

Goals

- Transfer of the beam with parameters which can be altered in wide ranges due to 1) use of different schemes of beam injection into Booster and 2) use of an electron cooling system.
- Ion stripping to a maximum charge state.

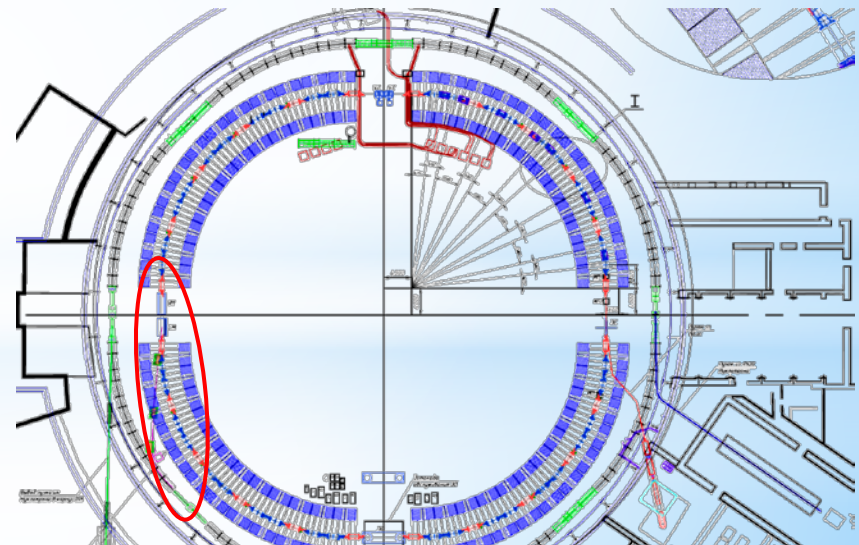
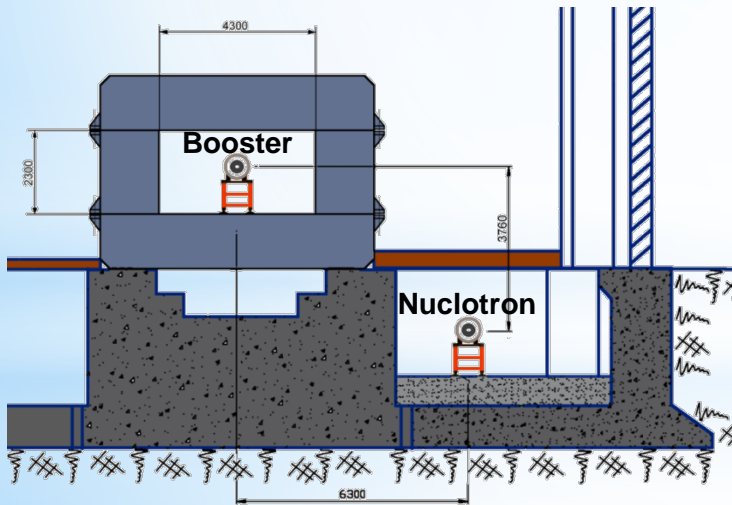

Beam transfer from Booster to Nuclotron

Beam Parameters

Ions:	
before stripping station	Au ³¹⁺
after stripping station	Au ⁷⁹⁺
Maximum magnetic rigidity of ions, T m:	
before stripping station	25
after stripping station	10
Ion number	$1.5 \cdot 10^9$

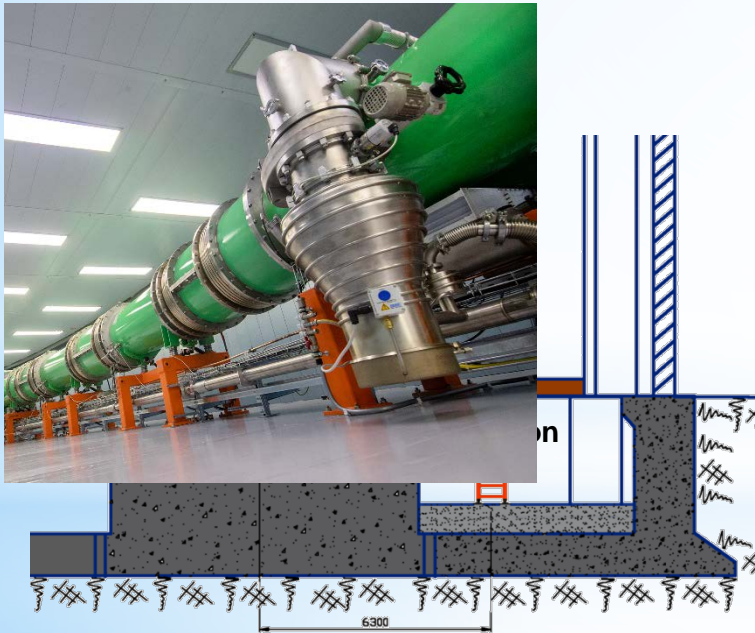

Goals

- Transfer of the beam with parameters which can be altered in wide ranges due to 1) use of different schemes of beam injection into Booster and 2) use of an electron cooling system.
- Ion stripping to a maximum charge state.

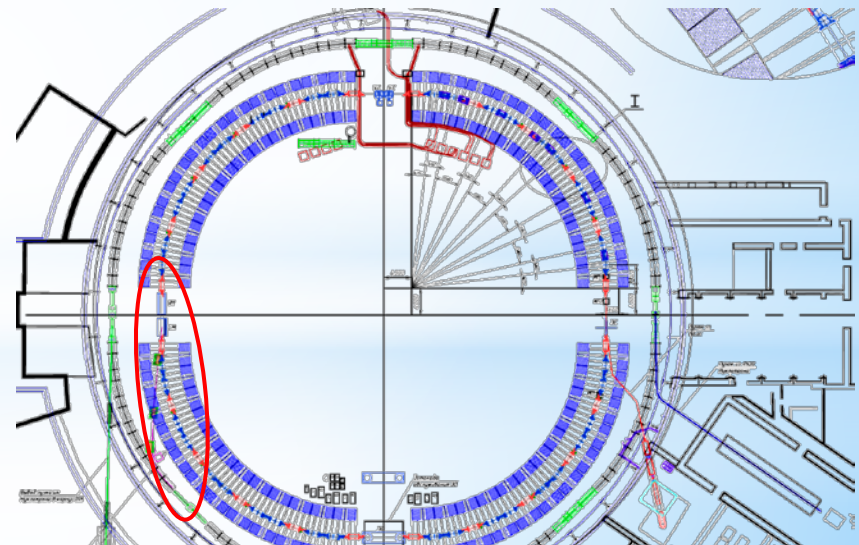

Beam transfer from Booster to Nuclotron

Beam Parameters

Ions:	
before stripping station	Au ³¹⁺
after stripping station	Au ⁷⁹⁺
Maximum magnetic rigidity of ions, T m:	
before stripping station	25
after stripping station	10
Ion number	$1.5 \cdot 10^9$

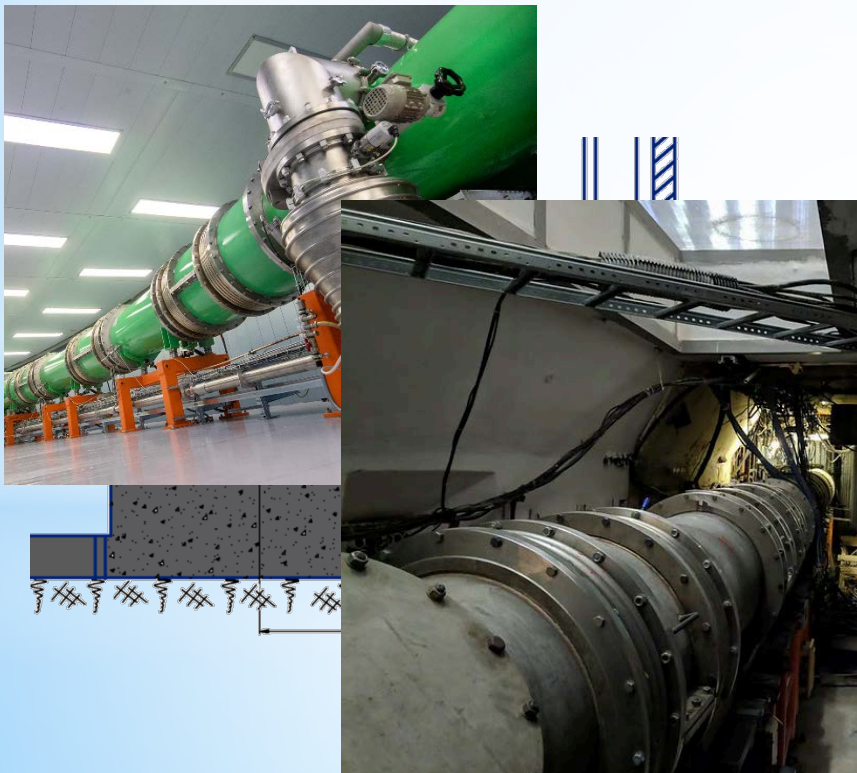

Goals

- Transfer of the beam with parameters which can be altered in wide ranges due to 1) use of different schemes of beam injection into Booster and 2) use of an electron cooling system.
- Ion stripping to a maximum charge state.

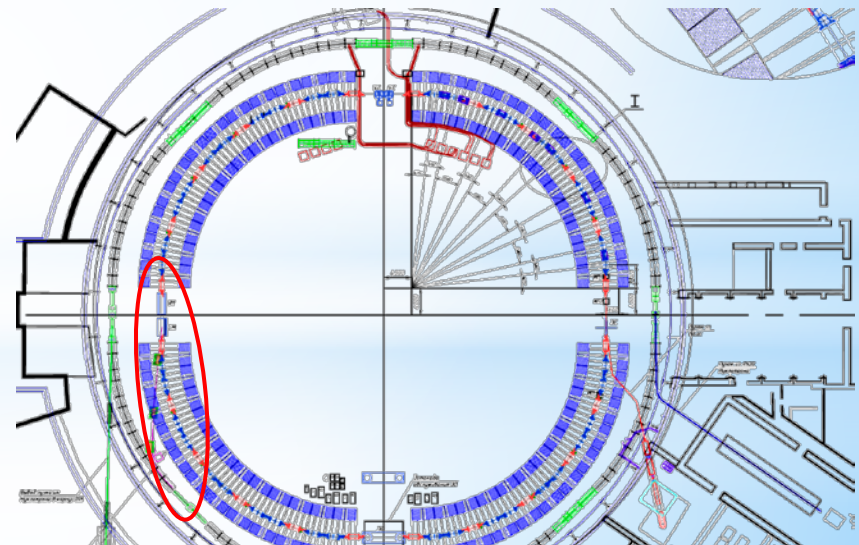

Fast extraction system of Booster

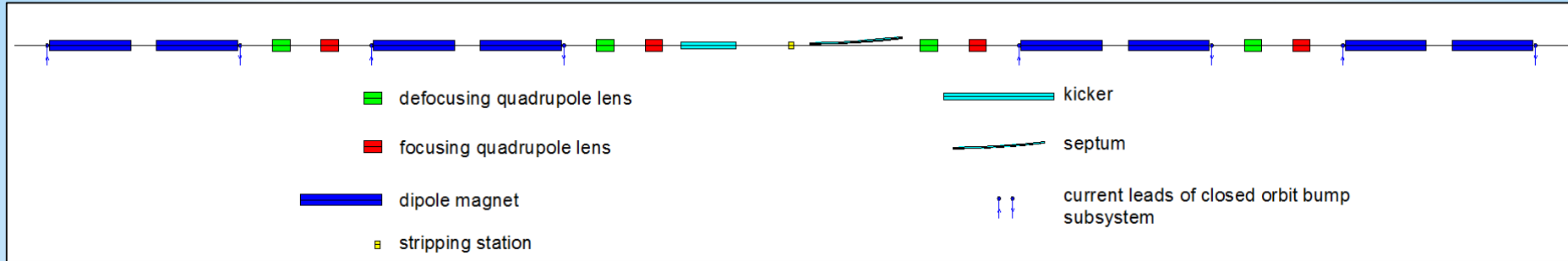

Closed orbit bump subsystem

PS # / dipoles	Beam bending angle in pair of dipoles, mrad	Nominal current, A	Max. current, A
1 / 2M5A-2M5B	1.55	49	150
2 / 2M6A-2M6B	3.6	115	150
3 / 3M2A-3M2B	3.48	111	150
4 / 3M3A-3M3B	1.79	57	150

3rd straight section

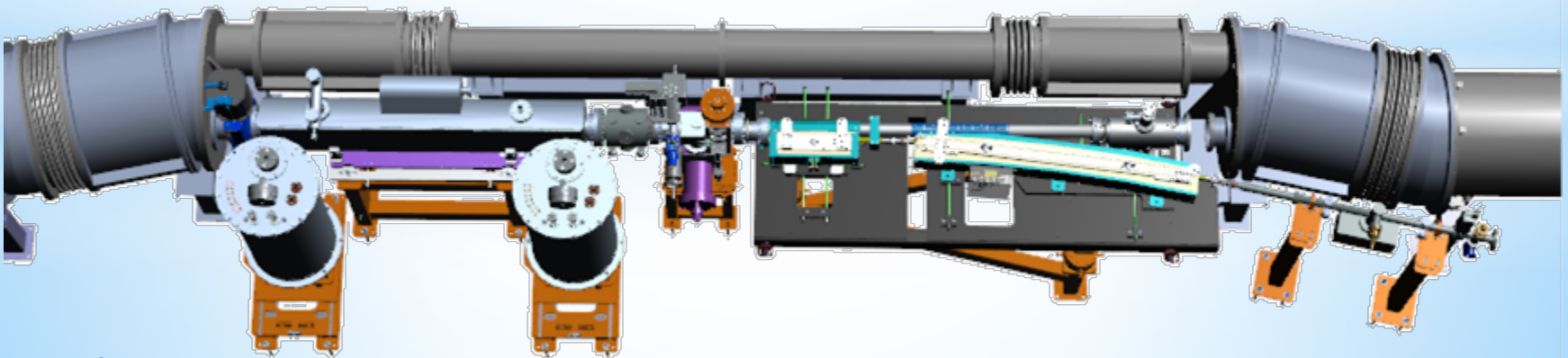

Fast extraction system of Booster

Kicker

Effective length, m	1.5
Max. field, T	0.18
Bending angle, mrad	10
Pulse duration, ns:	
rise	500
plateau	500
Current amplitude, kA	32

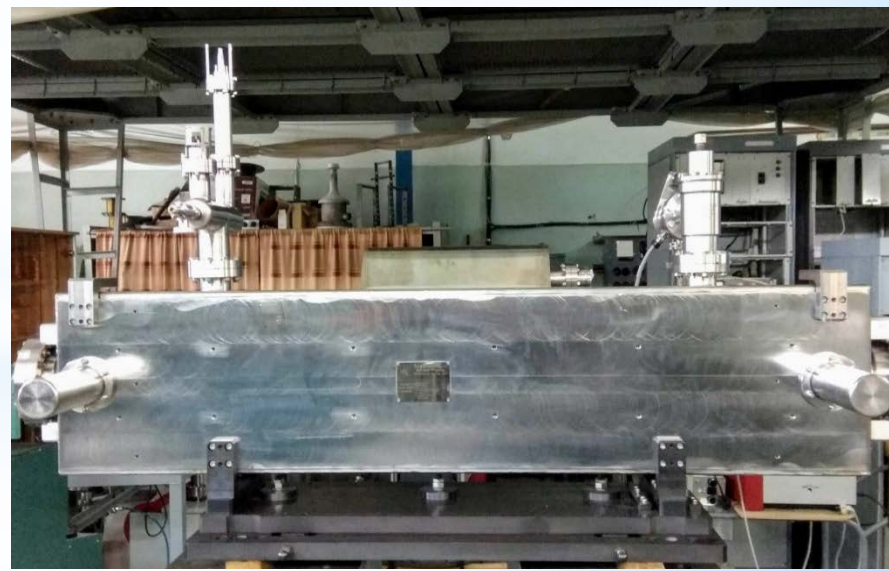
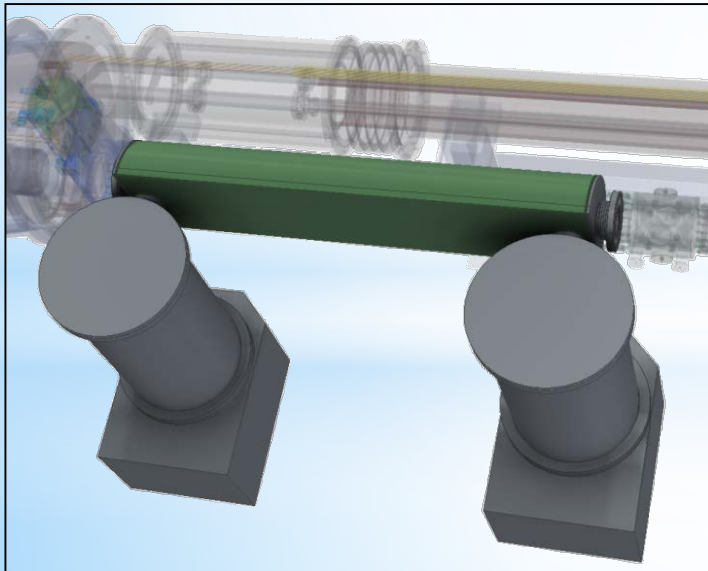
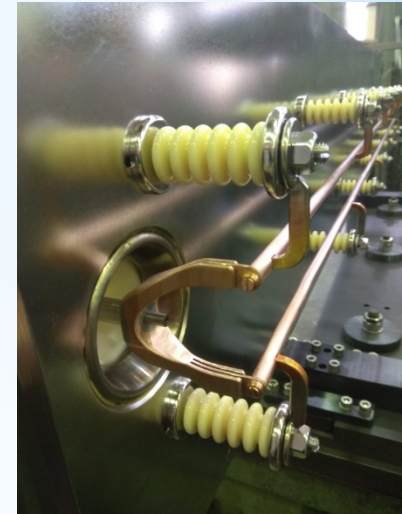
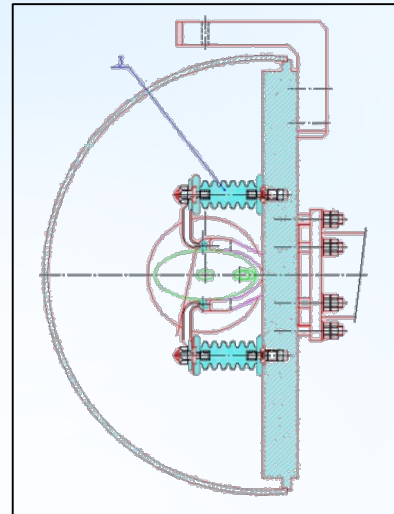

Fast extraction system of Booster

Kicker modulators

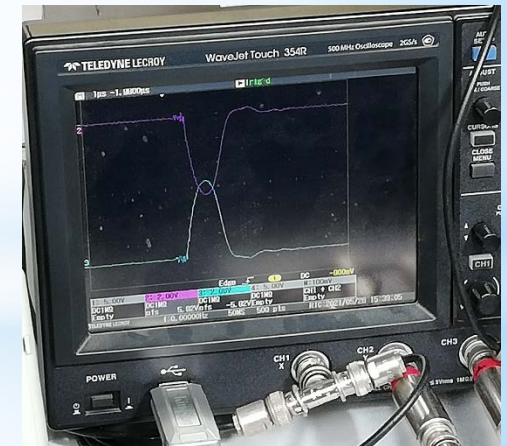
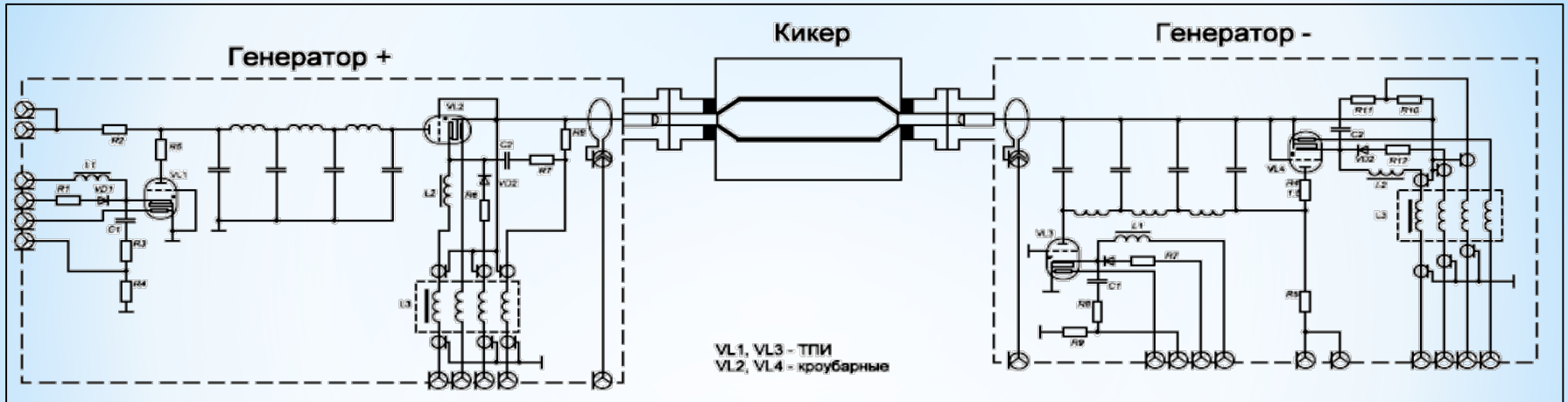

Fast extraction system of Booster

Septa

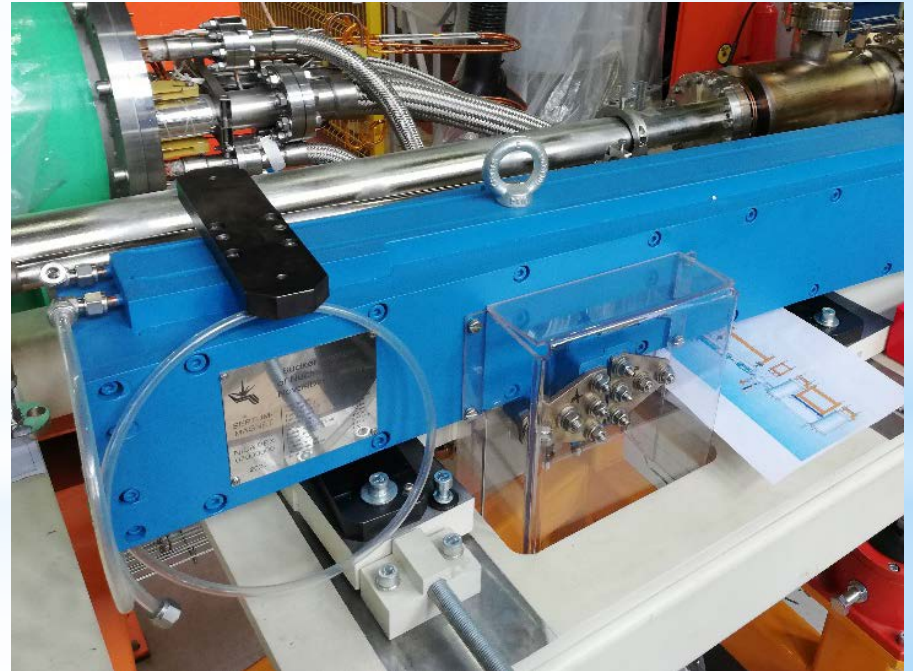
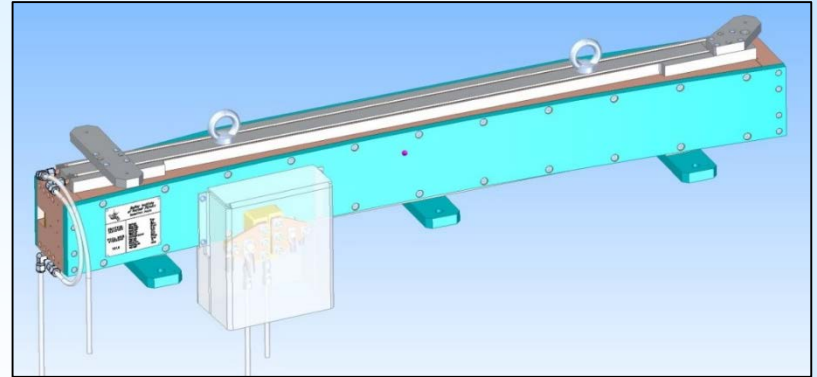
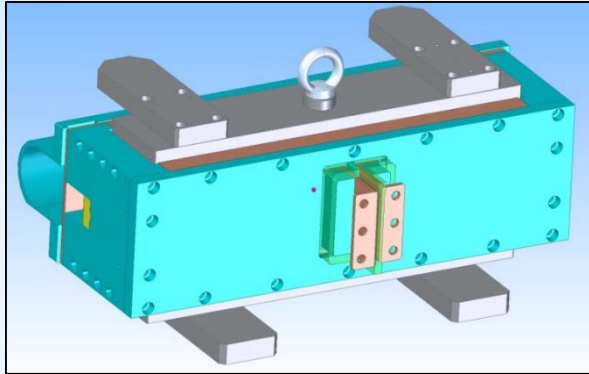

Fast extraction system of Booster

Stripping station

- Three stripping foils, remotely controlled.
- Change of stripping foils without opening vacuum chamber of the stripping station.
- Stripping foils –Cu. Thickness of foils – 45 μm ; 90 μm ; 150 μm .
- Foil aperture 50x70 mm².

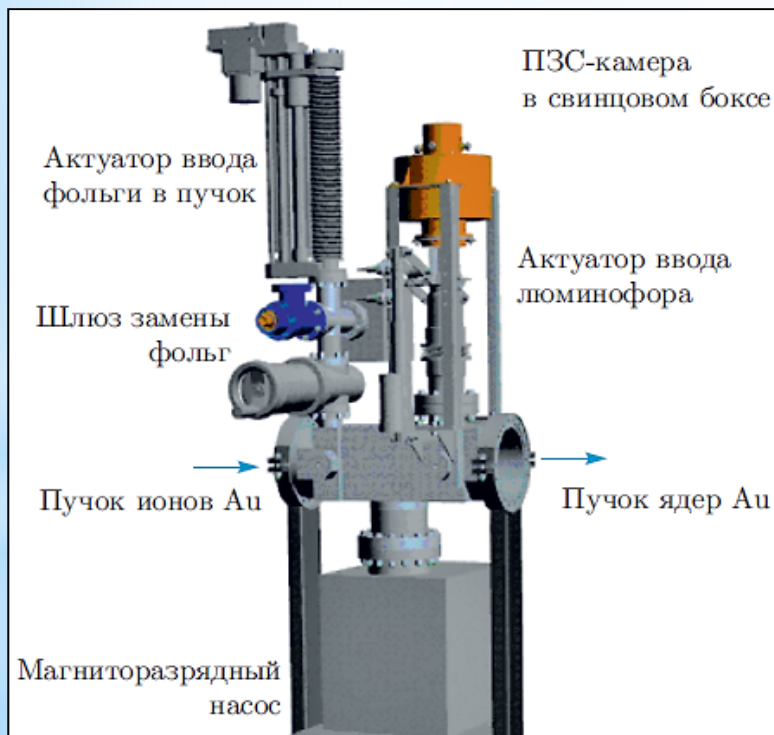

Fast extraction system of Booster

Stripping station

- Three stripping foils, remotely controlled.
- Change of stripping foils without opening vacuum chamber of the stripping station.
- Stripping foils –Cu. Thickness of foils – 45 μm ; 90 μm ; 150 μm .
- Foil aperture 50x70 mm².

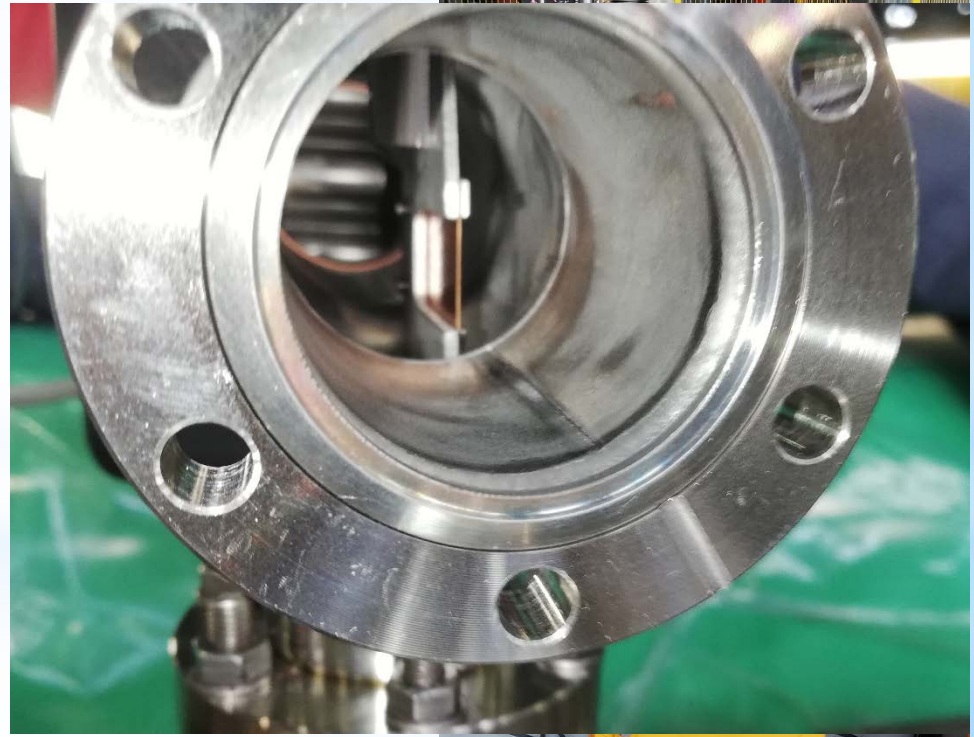
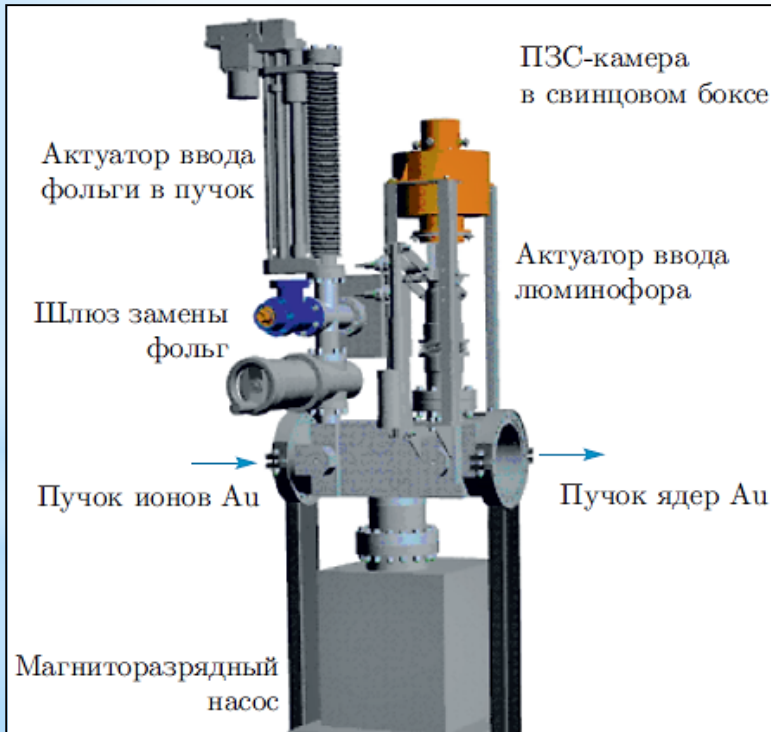

Booster-Nuclotron beam transport channel

Composition

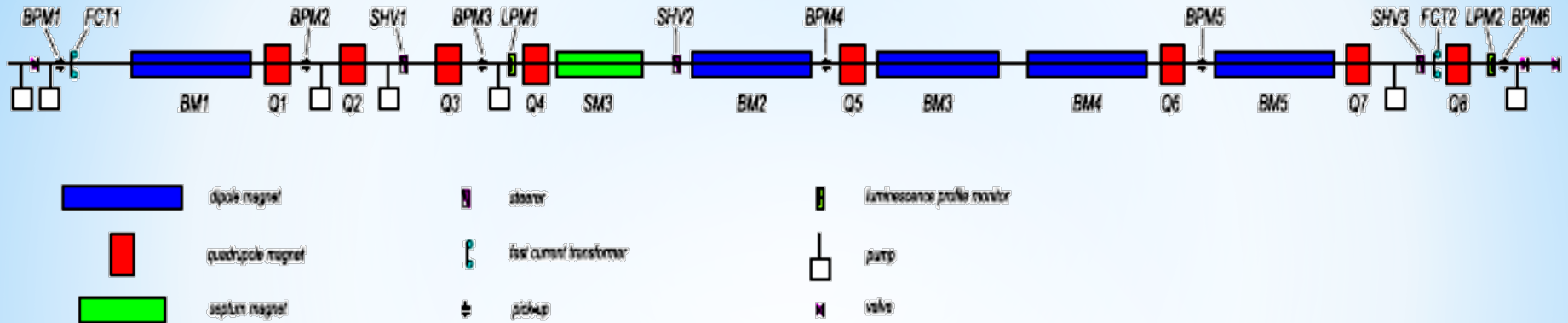

From above

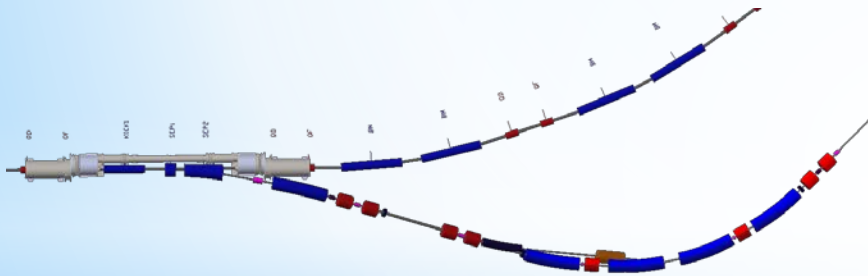

Aside

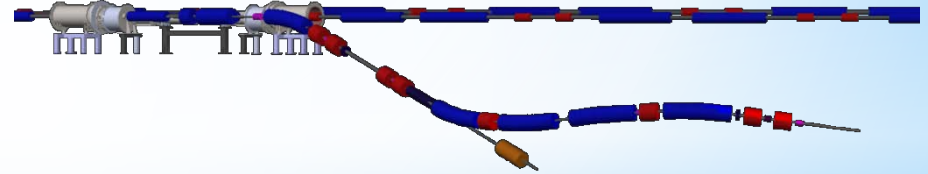

Booster-Nuclotron beam transport channel

Layout



Booster-Nuclotron beam transport channel

Layout



Booster-Nuclotron beam transport channel

Layout



Booster-Nuclotron beam transport channel

Layout



Booster-Nuclotron beam transport channel

Beam of Fe^{14+}

Luminescence screens

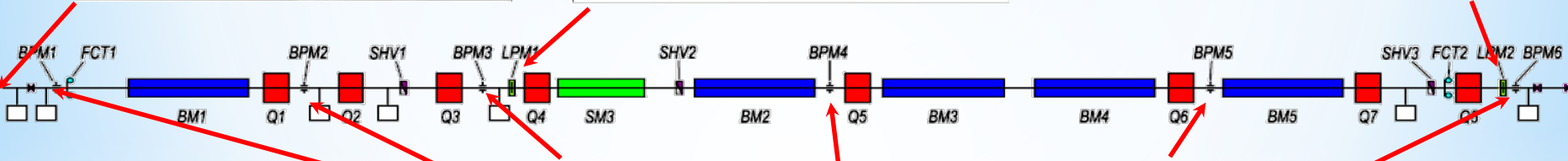
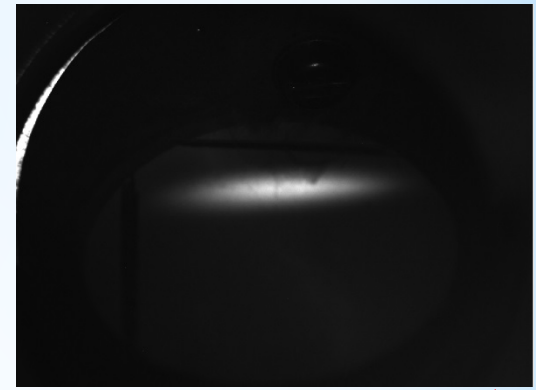
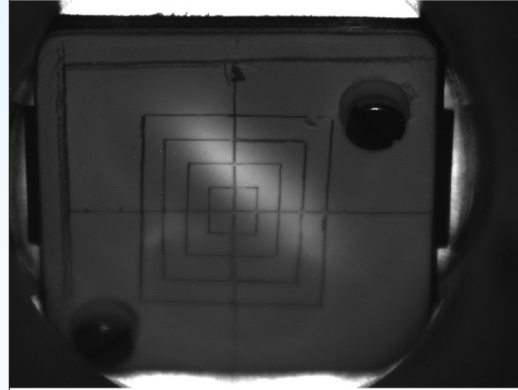
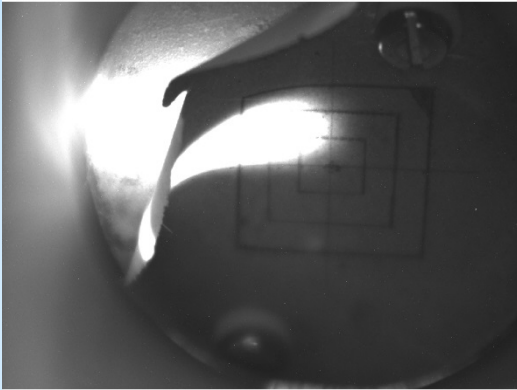

Pick-ups

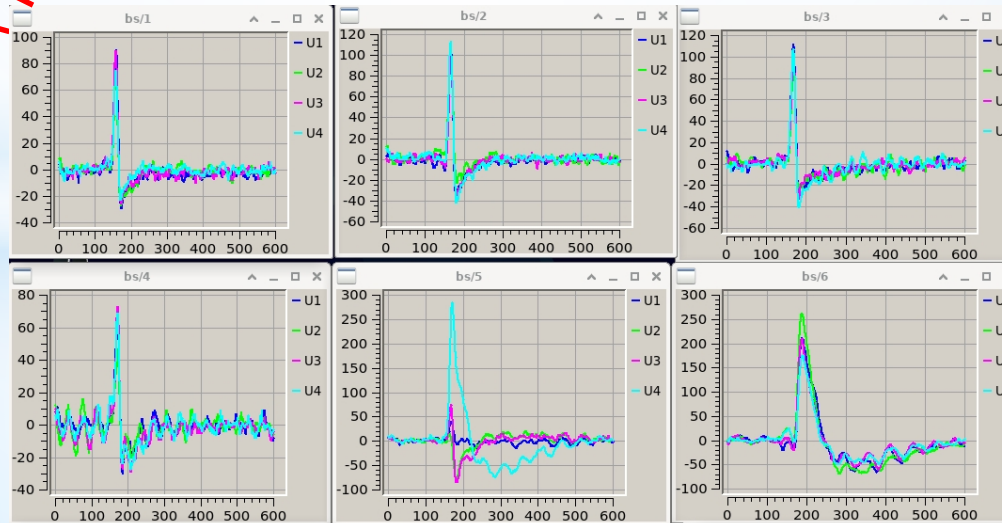

Beam injection system into Nuclotron

Composition

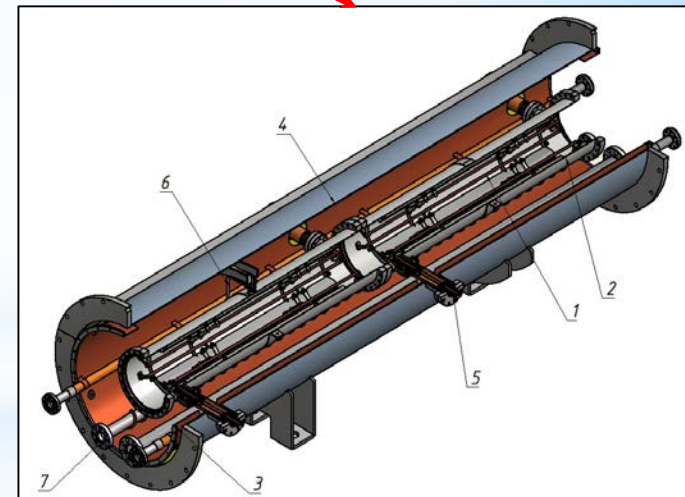
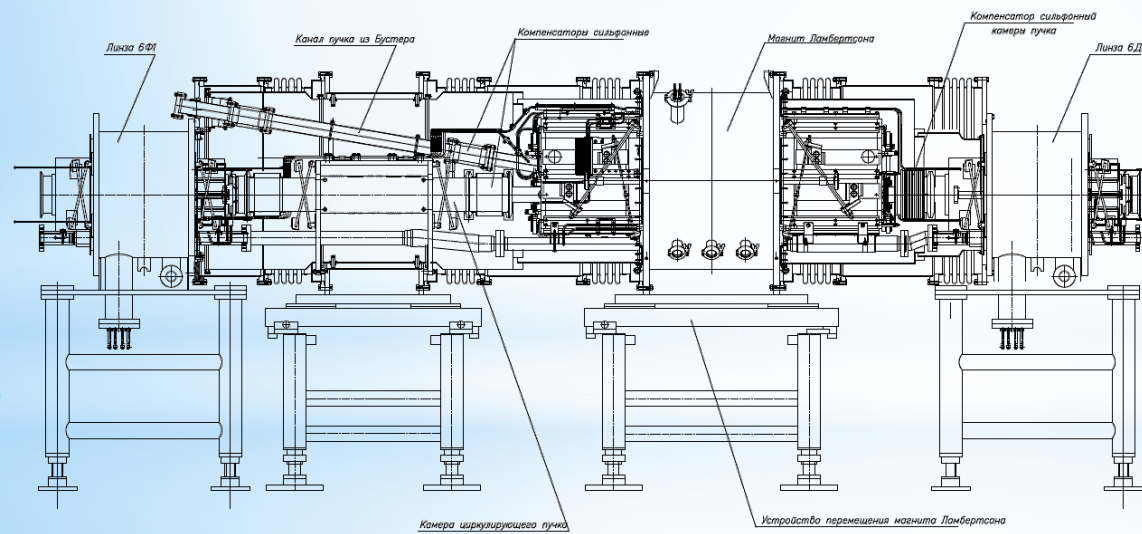
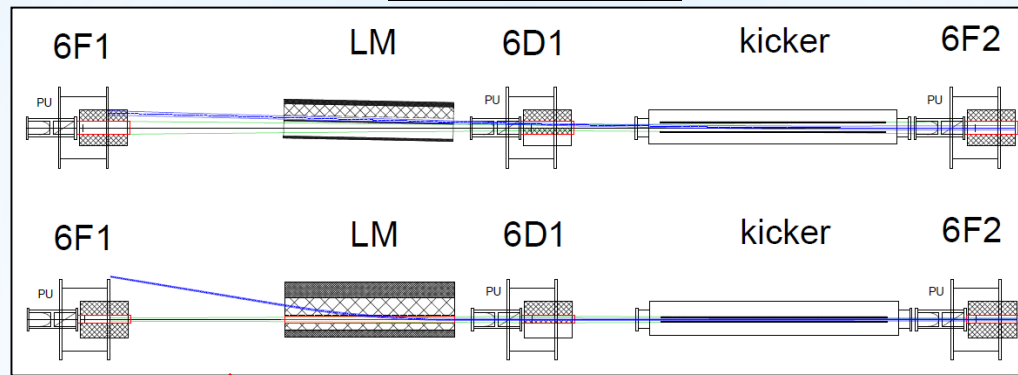

Beam injection system into Nuclotron

Kicker

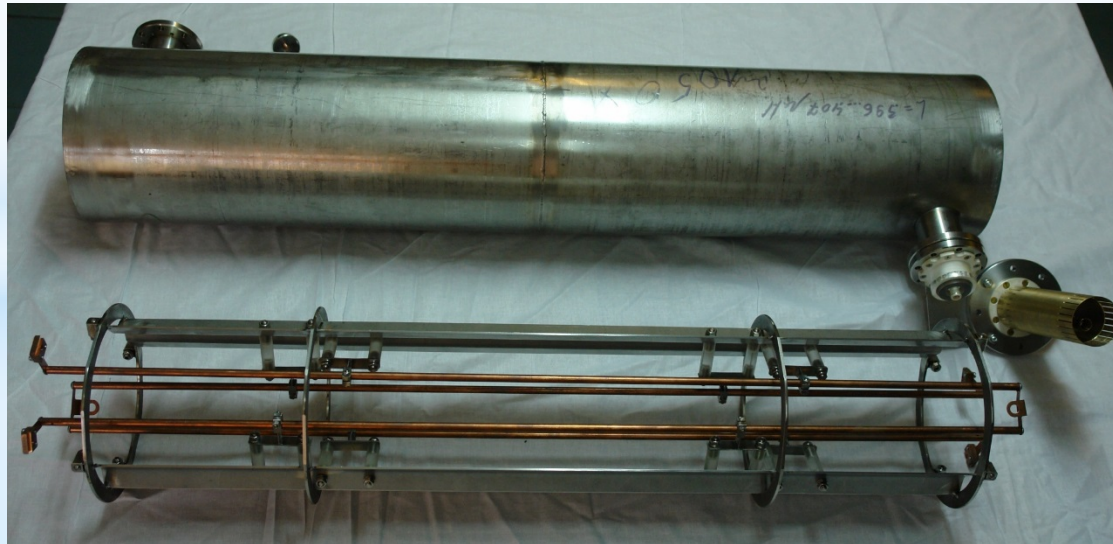
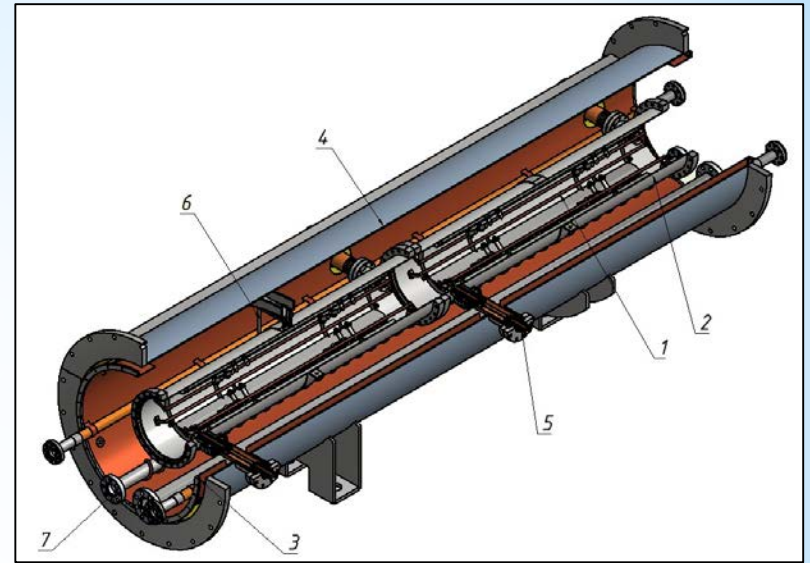
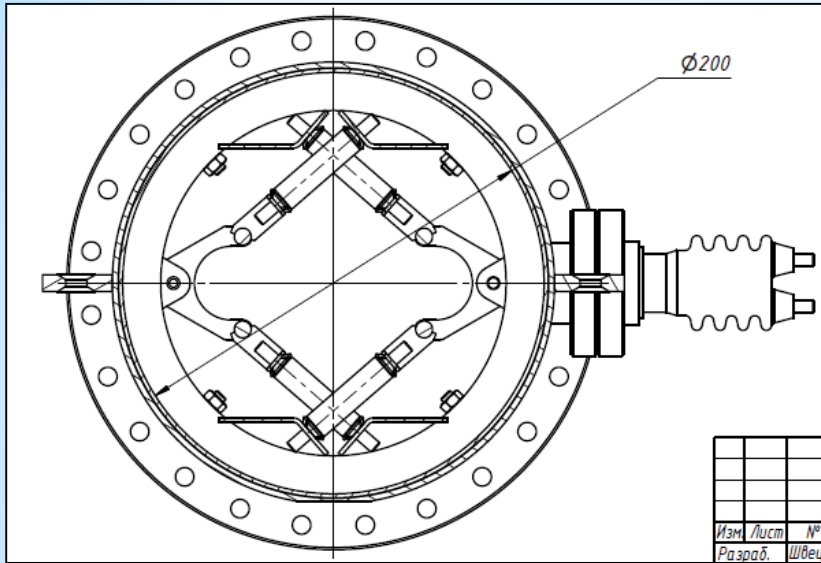

Beam injection system into Nuclotron

Lambertson magnet

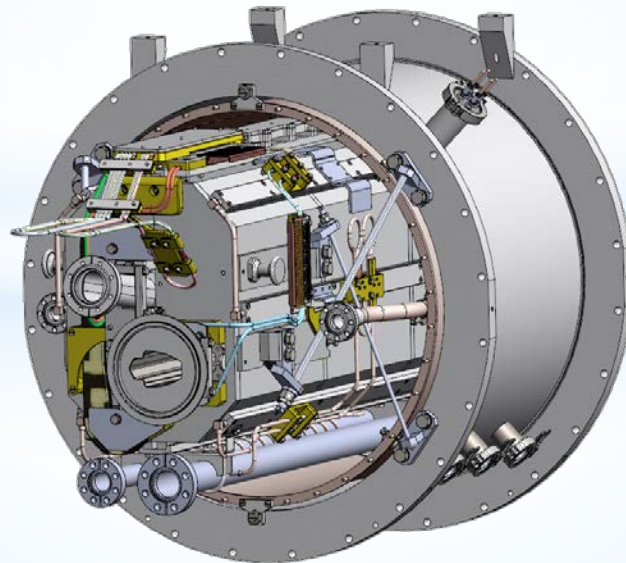
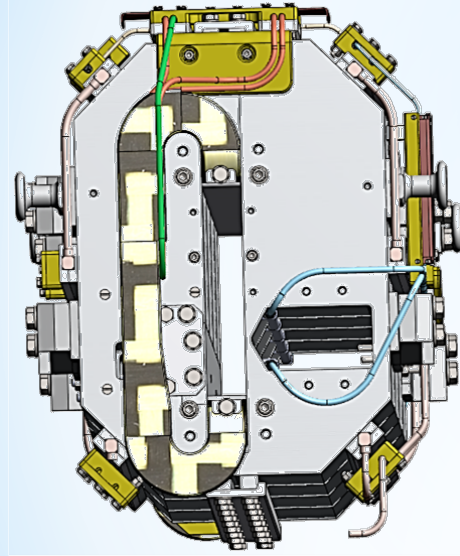

Beam injection system into Nuclotron

Lambertson magnet



Beam injection system into Nuclotron

Power supplies





THANK YOU FOR ATTENTION