

Polarization, Handedness and Flows

March 3, 2023



INFINUM-2023

JINR, Dubna

Oleg Teryaev (JINR)



Main Topics

- *Polarization in hadronic (inclusive) vs HIC (global): scattering vs reaction/event planes*
 - *Anomalous mechanism@JINR:*
Prediction of decrease with energy (2010) and value of $\sim 1\%$ at NICA (2013); Postdiction (2016) of larger polarization of anti- Λ ; Vortical structures: sheets (2016) quantized vortices (2017)
 - *Transmission of inclusive to global via direct flow (new!): $P_{Gl} = v_1 P_{incl}$*
 - **HANDEDNESS**
 - *Handedness as momentum space vortex*
 - *Octupole structure*
 - *Longitudinal handedness : direct flows and event planes of protons and pions*
 - **Tensor polarization of vector mesons**
 - *Correlation of polarizations in (anti)quark fusion*
 - *Geometric model relating different frames (and density matrix invariants) in hadronic collisions*
 - *Transmission of fusion alignment to global one via elliptic flow (new!)*
 - **Conclusions and Outlook**

Single Spin Asymmetries (vector polarization)

Simplest example - (non-relativistic) elastic pion-nucleon scattering $\pi \vec{N} \rightarrow \pi N$

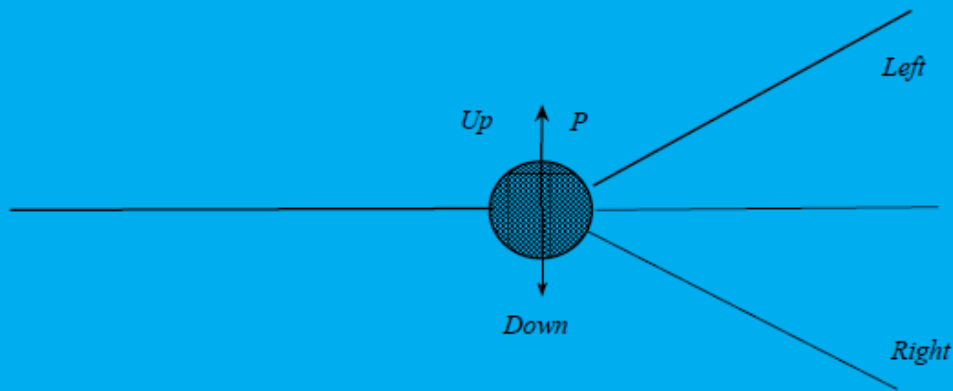

Polarization data has often been the graveyard of fashionable theories. If theorists had their way, they might just ban such measurements altogether out of self-protection.

J.D. Bjorken
St. Croix, 1987

$M = a + ib(\vec{\sigma}\vec{n})$ \vec{n} is the normal to the scattering plane.

Density matrix: $\rho = \frac{1}{2}(1 + \vec{\sigma}\vec{P})$,

Differential cross-section: $d\sigma \sim 1 + A(\vec{P}\vec{n})$, $A = \frac{2\text{Im}(ab^*)}{|a|^2 + |b|^2}$



SSA

- *Parity conservation – normal to (elastic or inclusive) scattering plane (HIC – angular momentum)*
- *Interference – LS coupling (HIC-hydrodynamical axial anomaly)*
- *T conservation – absorptive phases (HIC : dissipation)*



Phases in QCD

- *QCD factorization – soft and hard parts-*
- *Phases form soft, hard and overlap*
- *Assume (generalized) optical theorem – phase due to on-shell intermediate states – positive kinematic variable (= their invariant mass)*
- *Hard: Perturbative (a la QED: Barut, Fronsdal (1960): Kane, Pumplin, Repko (78) Efremov (78)*

Perturbative PHASES IN QCD

QCD factorization: where to borrow imaginary parts?

Simplest way: from short distances - loops in partonic subprocess. Quarks elastic scattering (like $q - e$ scattering in DIS):

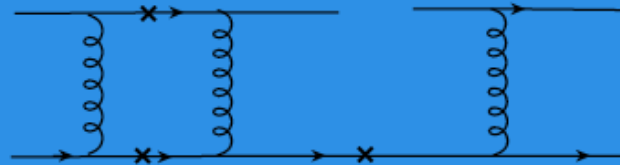

$$A \sim \frac{\alpha_S^{m_{PT}}}{p_T^2 + m^2}$$

Large SSA "...contradict QCD or its applicability"

Short+ large overlap– twist 3

- *Quarks – only from hadrons*
- *Various options for factorization – shift of SH separation (prototype of duality)*

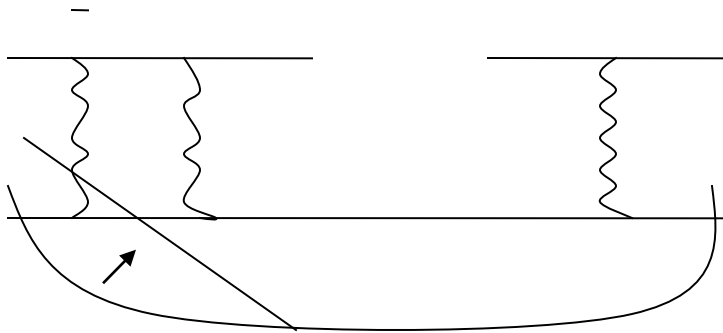

- *New option for SSA: Instead of 1-loop twist 2 – Born twist 3: Efremov, OT (85, Fermion poles); Qiu, Sterman (91, GLUONIC poles)*



Λ -polarisation

- *Self-analyzing (spin-momentum couplings) in weak decay*
- *Directly related to s -quarks polarization: complementary probe of strangeness*
- *Widely explored in hadronic processes*
- *Disappearance-probe of QCD matter formation (Hoyer; Jacob, Rafelsky: '87): Randomization – smearing – of the scattering plane*



Global polarization

- *Global polarization normal to REACTION plane*
- *Predictions (Z.-T.Liang et al.): large orbital angular momentum -> large polarization*
- *Search by STAR (Selyuzhenkov et al.'07) : polarization NOT found at % level!*
- *Due to locality of LS coupling while large orbital angular momentum is distributed*
- *How to transform rotation to spin?*

Anomalous mechanism – polarization similar to C(A)VE (talks of V. Zakharov, G. Prokhorov, Yu. Ivanov)

- 4-Velocity is also a **GAUGE FIELD** (V.I. Zakharov et al): $\mu Q = \mu J_0 V^0 \rightarrow \mu J_\gamma V^\gamma$

$$e_j A_\alpha J^\alpha \Rightarrow \mu_j V_\alpha J^\alpha$$

- **Triangle anomaly** leads to polarization of quarks and hyperons (Rogachevsky, Sorin, OT '10)
- Analogous to anomalous gluon contribution to nucleon spin (Efremov, OT'88)
- **4-velocity instead of gluon field!**

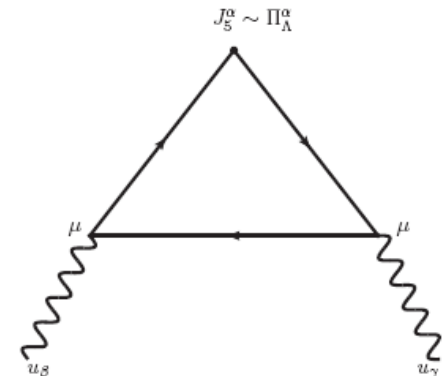

"Anomalous" mechanism

O. Rogachevsky, A. Sorin, O. Teryaev
 Chiral vortaic effect and neutron
 asymmetries in heavy-ion collisions
 PHYSICAL REVIEW C 82, 054910 (2010)

Prediction of decrease with energy (due to chemical potential)

One would expect that polarization is proportional to the anomalously induced axial current [7]

$$j_A^\mu \sim \mu^2 \left(1 - \frac{2\mu n}{3(\epsilon + P)}\right) \epsilon^{\mu\nu\lambda\rho} V_\nu \partial_\lambda V_\rho, \quad (6)$$

where n and ϵ are the corresponding charge and energy densities and P is the pressure. Therefore, the μ dependence of polarization must be stronger than that of the CVE, leading to the effect's increasing rapidly with decreasing energy.

This option may be explored in the framework of the program of polarization studies at the NICA [17] performed at collision points as well as within the low-energy scan program at the RHIC.

Prediction of $P \sim 1\%$

BAZNAT, GUDIMA, SORIN, AND TERYAEV

$$\langle P_\Lambda \rangle \sim \frac{\langle \mu^2 \rangle N_c H}{2\pi^2 \langle N_\Lambda \rangle}$$

PHYSICAL REVIEW C 88, 061901(R) (2013)

For numerical estimate at NICA energies, we take (see Fig. 3) $H = 30 \text{ fm}^2 (c = 1)$ and, as typical values, $\langle \mu^2 \rangle = 900 \text{ MeV}^2$, $\langle N_\Lambda \rangle = 15$ to get $\langle P_\Lambda \rangle \sim 0.8\%$. This value is

Postdiction of larger polarization of antilambdas

ALEXANDER SORIN AND OLEG TERYAEV

PHYSICAL REVIEW C 95, 011902(R) (2017)

The proportionality of the polarization to the square of the chemical potential related to C -even parity of axial current leads to the same sign of polarization of Λ and $\bar{\Lambda}$ hyperons. The smaller number of the latter should result in a larger fraction of the axial charge, corresponding to each antihyperon and to a larger absolute value of polarization. Detailed numerical sim-

Vortical structures(cf. talks of Yu. Ivanov, V. Nesterenko)

PHYSICAL REVIEW C **93**, 031902(R) (2016)

Femto-vortex sheets and hyperon polarization in heavy-ion collisions

Mircea Baznat,^{1,2,*} Konstantin Gudima,^{1,2,†} Alexander Sorin,^{1,3,‡} and Oleg Teryaev^{1,3,§}

larger. The growth of polarization in the fragmentation regions may be considered as an indirect probe of toroidal structures formation.

PHYSICAL REVIEW D **96**, 096023 (2017)

From the chiral vortical effect to polarization of baryons: A model

Oleg V. Teryaev¹ and Valentin I. Zakharov²

It is worth emphasizing that the total angular momentum associated with a given vortex is much larger than the “spin” of the infinitely thin core of the vortex. Indeed, the fluid rotates around the core and, therefore, carries angular momentum. This angular momentum \mathcal{L} can be estimated as

$$\mathcal{L} = \int_0^{l_{\text{vortex}}} \left(\frac{\mu}{d^2} \cdot 2\pi r dr \right) v_\phi(r) r \sim \left(\frac{l_{\text{vortex}}}{d} \right)^2, \quad (36)$$

$$n_{\text{vortices}} = \frac{\mu}{\pi} \int_A d^2x |\vec{\omega}|.$$

$$(j_5^z)_{\text{vortex}} = \frac{\mu_5^I \kappa}{2\pi} \delta(x, y)$$

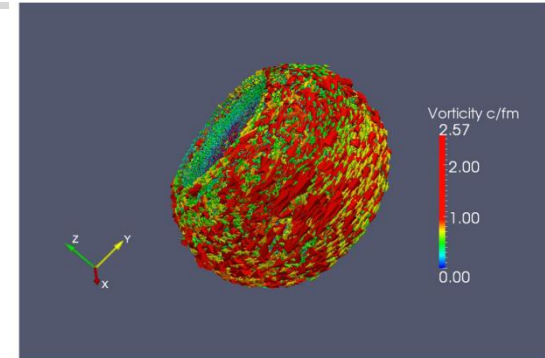

FIG. 3. The vortex sheet.

Back to inclusive/elastic polarization: momentum space vortex (cf Lisa, Torrieri et al)?

May it contribute to global polarization?

$$d\delta(\phi) \sim 1 + (P_d P_i) = 1 + P_d P_i \cos \phi$$

$$\langle d\delta(\phi) \rangle$$

$$= \langle (1 + P_d P_i \cos \phi) (1 + 2 v_1 \cos \phi) \rangle$$

$$= 1 + P_d P_i v_1$$

New(?): $P_{gl} = P_i v_1$

Can be important at low energies



Modelling for NICA

Physics of Particles and Nuclei Letters, 2021, Vol. 18, No. 4, pp. 429–438. © Pleiades Publishing, Ltd., 2021.

PHYSICS OF ELEMENTARY PARTICLES
AND ATOMIC NUCLEI. EXPERIMENT

Monte Carlo Study of Λ Polarization at MPD

E. Nazarova^{a, *}, R. Akhat^{a, b}, M. Baznat^{a, c}, O. Teryaev^a, and A. Zinchenko^a

$$P = -\left(\frac{12p_T}{\Delta x_0 M^2} \frac{1 - \xi(x_F)}{1 + 3\xi(x_F)}\right)^2;$$
$$\xi(x_F) = \frac{1 - x_F}{3} + 0.1x_F,$$

Complementing with flow modelling:
contribution to global polarization

Momentum vortices: Handedness - directly observable P-odd momentum correlations

- *A. V. Efremov et al. : jets in e^+e^- annihilation (LEP, BELLE)*
- *HIC: OT, Usubov, [arXiv:1406.4451](https://arxiv.org/abs/1406.4451), PRC 92(2015)014906)*
- *Average = 0: Phase space – 8 octants*

Octant	Momentum
0	$p_x > 0, p_y > 0, p_z > 0$
1	$p_x > 0, p_y > 0, p_z \leq 0$
2	$p_x > 0, p_y \leq 0, p_z > 0$
3	$p_x > 0, p_y \leq 0, p_z \leq 0$
4	$p_x \leq 0, p_y > 0, p_z > 0$
5	$p_x \leq 0, p_y > 0, p_z \leq 0$
6	$p_x \leq 0, p_y \leq 0, p_z > 0$
7	$p_x \leq 0, p_y \leq 0, p_z \leq 0$

$$\eta = \frac{\sum (\vec{p}_3, \vec{p}_2, \vec{p}_1)}{\sum |(\vec{p}_3, \vec{p}_2, \vec{p}_1)|}$$

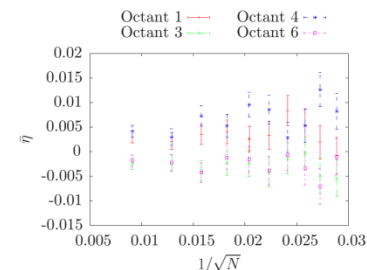
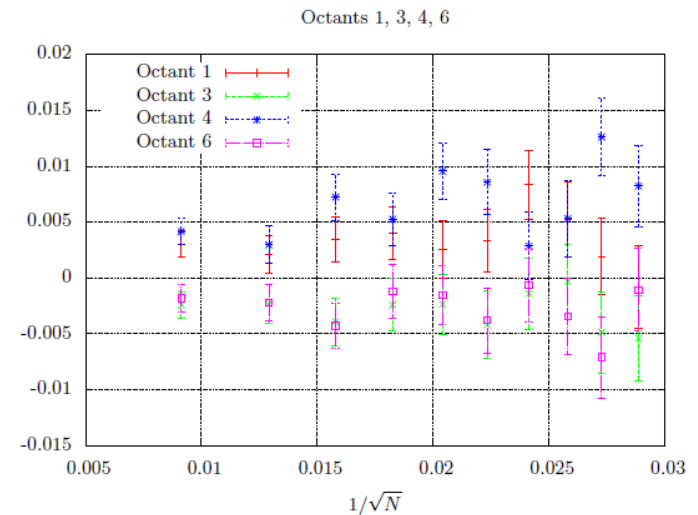
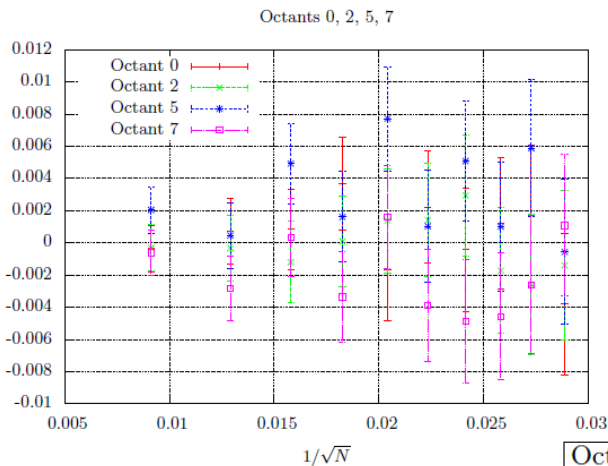

FIG. 8. (Color online) Dependence of $\bar{\eta}$ on $1/\sqrt{N}$, for impact parameter $b = 7$ fm. Octants 1, 3, 4, and 6.

Handedness separation

- *Indication for small separation effect in some of the octants*



Octant	Momentum
0	$p_x > 0, p_y > 0, p_z > 0$
1	$p_x > 0, p_y > 0, p_z \leq 0$
2	$p_x > 0, p_y \leq 0, p_z > 0$
3	$p_x > 0, p_y \leq 0, p_z \leq 0$
4	$p_x \leq 0, p_y > 0, p_z > 0$
5	$p_x \leq 0, p_y > 0, p_z \leq 0$
6	$p_x \leq 0, p_y \leq 0, p_z > 0$
7	$p_x \leq 0, p_y \leq 0, p_z \leq 0$

Handedness vs helicity separation

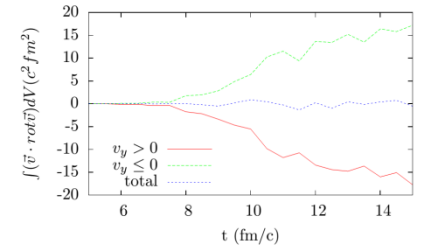

$$\langle \mathbf{v} \text{ curl } \mathbf{v} \rangle \sim \epsilon_{ijk} \langle p_i p_j p_k \rangle / \mathcal{H}$$

Labelling: by size or particles type

Longitudinal handedness of pion-proton pairs: correlation via flows

$$\langle \sin(\Delta\phi) \rangle = v_1 v'_1 \sin(\Delta\Psi_E)$$

Correlation of 2 pion-proton pairs?



Tensor polarization

- Vector: $(\sigma(+)-\sigma(-))/(\sigma(+)+\sigma(-))$

Tensor:

$$(\sigma(+)+\sigma(-)-2\sigma(0))/(\sigma(+)+\sigma(-)+\sigma(0))$$

Simplest way : meson from

Polarized (anti) quarks (small quadratic effect)

BUT: correlation is enough!

Alignment from correlations (Efremov, OT'82)

$$\rho = \frac{1}{4} (\mathbf{I} \otimes \mathbf{I} + a_i \sigma_i \otimes \mathbf{I} + b_j \mathbf{I} \otimes \sigma_j + c_{ij} \sigma_i \otimes \sigma_j)$$

$$\rho_{00} = \frac{1 - c_{zz} + c_{xx} + c_{yy}}{3 + c_{zz} + c_{xx} + c_{yy}} \equiv \frac{1 - \text{Sp}_{\parallel} \mathbf{c} + \text{Sp}_{\perp} \mathbf{c}}{3 + \text{Sp} \mathbf{c}}$$

$$\sum_i \rho_{00}^i = 1; \quad \sum_i S_{\pi} = 0.$$



Correlations in initial and final state: decays to lepton pairs

Same expression for density matrix in terms of c_{zz} and coefficient of $\cos^2\theta$ in angular distribution

$$c_{zz} = \lambda_{\theta}$$

Relativistic case: for massless fermions

$$\lambda_{\theta} = 1$$

Opposite helicities – same momentum projections - transverse photon

Angular distribution

general form of angular distribution (wrt particular frame)

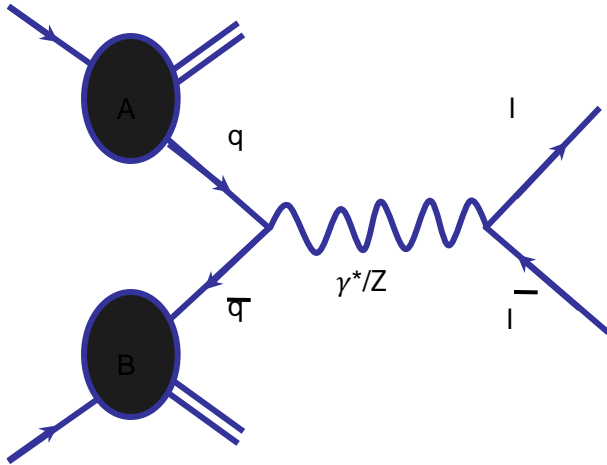

$$\begin{aligned} \frac{1}{\sigma} \frac{d\sigma}{d\Omega} = & \frac{3}{4\pi} \frac{1}{3 + \lambda_\theta} \left(1 + \lambda_\theta \cos^2 \theta + \lambda_{\theta\phi} \sin 2\theta \cos \phi \right. \\ & + \lambda_\phi \sin^2 \theta \cos 2\phi + \lambda_{\perp\phi} \sin^2 \theta \sin 2\phi \\ & + \lambda_{\perp\theta\phi} \sin 2\theta \sin \phi + 2A_\theta \cos \theta \\ & \left. + 2A_\phi \sin \theta \cos \phi + 2A_{\perp\phi} \sin \theta \sin \phi \right) \end{aligned}$$

Angular distribution

general form of angular distribution :

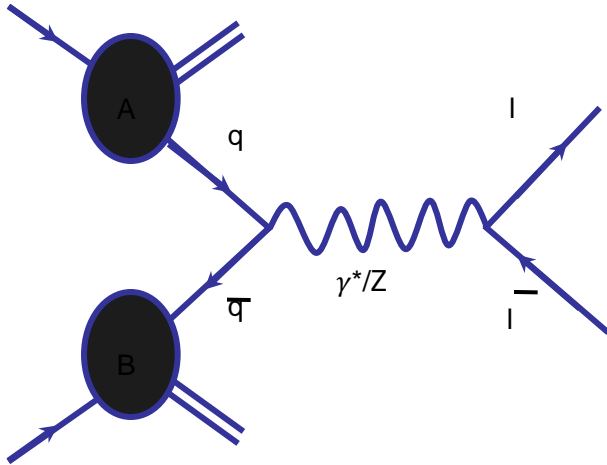

$$\begin{aligned} \frac{1}{\sigma} \frac{d\sigma}{d\Omega} = & \frac{3}{4\pi} \frac{1}{3 + \lambda_\theta} \left(1 + \lambda_\theta \cos^2 \theta + \lambda_{\theta\phi} \sin 2\theta \cos \phi \right. \\ & + \lambda_\phi \sin^2 \theta \cos 2\phi + \lambda_{\perp\phi} \sin^2 \theta \sin 2\phi \\ & + \lambda_{\perp\theta\phi} \sin 2\theta \sin \phi + 2A_\theta \cos \theta \\ & \left. + 2A_\phi \sin \theta \cos \phi + 2A_{\perp\phi} \sin \theta \sin \phi \right) \end{aligned}$$

Invariants

- Facilitate comparison b/w experiments, theory and experiment
- Reveal systematic biases



General density matrix

- *Angular distribution*

$$d\sigma \propto 1 + \lambda \cos^2 \theta + \mu \sin 2\theta \cos \phi + \frac{\nu}{2} \sin^2 \theta \cos 2\phi + \rho \sin 2\theta \sin \phi + \sigma \sin^2 \theta \sin 2\phi$$

- *Positivity of the matrix (= hadronic tensor in dilepton rest frame)*

$$M_0 = \begin{pmatrix} \frac{1-\lambda}{2} & \mu & \rho \\ \mu & \frac{1+\lambda-\nu}{2} & \sigma \\ \rho & \sigma & \frac{1+\lambda+\nu}{2} \end{pmatrix} \quad \begin{aligned} |\lambda| \leq 1, \quad |\nu| \leq 1 + \lambda, \quad \mu^2 &\leq \frac{(1-\lambda)(1+\lambda-\nu)}{4} \\ \rho^2 &\leq \frac{(1-\lambda)(1+\lambda+\nu)}{4}, \quad \sigma^2 \leq \frac{(1+\lambda)^2 - \nu^2}{4} \end{aligned}$$

- *+ cubic – det $M_0 > 0$*

Kinematic azimuthal asymmetry from polar one

Only polar

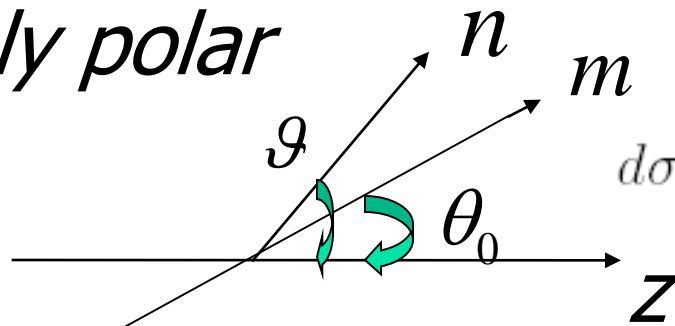

$$d\sigma \propto 1 + \lambda_0 (\vec{n}\vec{m})^2 = 1 + \lambda_0 \cos^2 \theta_{nm}$$

asymmetry with respect to m!

$$\cos \theta_{nm} = \cos \theta \cos \theta_0 + \sin \theta \sin \theta_0 \cos \phi$$

- azimuthal

angle appears with new

$$\lambda = \lambda_0 \frac{2 - 3 \sin^2 \theta_0}{2 + \lambda_0 \sin^2 \theta_0}$$

$$\nu = \lambda_0 \frac{2 \sin^2 \theta_0}{2 + \lambda_0 \sin^2 \theta_0}$$

Generalized Lam-Tung relation

(OT'05)

- *Relation between coefficients (high school math sufficient!) - **INVARIANT***
$$\lambda_0 = \frac{\lambda + \frac{3}{2}\nu}{1 - \frac{1}{2}\nu}$$
- *Reduced to standard Lam Tung relation for transverse polarization ($\lambda_0 = 1$)*
- *LT - contains two very different inputs: kinematical asymmetry+transverse polarization*
- *This "Geometric Model" was successfully applied for description of DY and J/ Ψ production (Peng, Chang, McClellan, OT, PRD, PLB, 15-21)*



Alignment and elliptic flow

In terms of d.m. (**new?**) geometric model reads

$$\rho_{00}(\Theta) = \rho_{00} + \sin^2 \Theta (1 - 3\rho_{00}) / 2$$

Weighting with elliptic flow in the central region (preliminary): **global from correlational**

$$P_{00(GI)} = (1/3 - 4v_2/5 - 26\rho_{00(\text{corr})} v_2/45) / (1 + 2v_2/3)$$



Conclusions/Outlook

Flows: may transform partonic/hadronic polarization effects to global ones

Vortical structures: momentum vs coordinate

Anomaly mechanisms of polarization explain their many qualitative features

Kinematical vortical effect: application for polarization?



Generalized Lam-Tung relation

- *Relation between coefficients (high school math sufficient!)*

$$\lambda_0 = \frac{\lambda + \frac{3}{2}\nu}{1 - \frac{1}{2}\nu}$$

- *Reduced to standard LT relation for transverse polarization ($\lambda_0 = 1$)*
- *LT - contains two very different inputs: kinematical asymmetry+transverse polarization*
- *Non-coplanarity – violation of LT*



From (chiral) quarks to hadrons: quark-hadron duality via axial charge

- *Induced axial charge*

$$c_V = \frac{\mu_s^2 + \mu_A^2}{2\pi^2} + \frac{T^2}{6}, \quad Q_5^s = N_c \int d^3x c_V \gamma^2 \epsilon^{ijk} v_i \partial_j v_k$$

- *Neglect axial chemical potential*
- $\mu_{s(q)} \rightarrow \mu_B/3 - \mu_S$
- *T-dependent term (Landsteiner's gravity anomaly);
no π^2 in denominator : "hint" for role of Unruh effect
($T=a/2\pi$; poster #130 by G. Prokhorov)*
- *Lattice simulations: suppressed by order of
magnitude due to collective effects – responsible for
RHIC/LHC polarization?*



Energy dependence

- *Coupling -> chemical potential*

$$Q_5^g = \frac{N_c}{2\pi^2} \int d^3x \mu_s^2(x) \gamma^2 \epsilon^{ijk} v_i \partial_j v_k$$

- *Field -> velocity; (Color) magnetic field strength -> vorticity;*
- *Topological current -> hydrodynamical helicity*
- *Large chemical potential: appropriate for NICA/FAIR energies*

One might compare the prediction below with the right panel figures

O. Rogachevsky, A. Sorin, O. Teryaev
Chiral vortical effect and neutron asymmetries in heavy-ion collisions
PHYSICAL REVIEW C 82, 054910 (2010)

One would expect that polarization is proportional to the anomalously induced axial current [7]

$$j_A^\mu \sim \mu^2 \left(1 - \frac{2\mu n}{3(\epsilon + P)} \right) \epsilon^{\mu\nu\lambda\rho} V_\nu \partial_\lambda V_\rho, \quad (6)$$

where n and ϵ are the corresponding charge and energy densities and P is the pressure. Therefore, the μ dependence of polarization must be stronger than that of the CVE, leading to the effect's increasing rapidly with decreasing energy.

This option may be explored in the framework of the program of polarization studies at the NICA [17] performed at collision points as well as within the low-energy scan program at the RHIC.

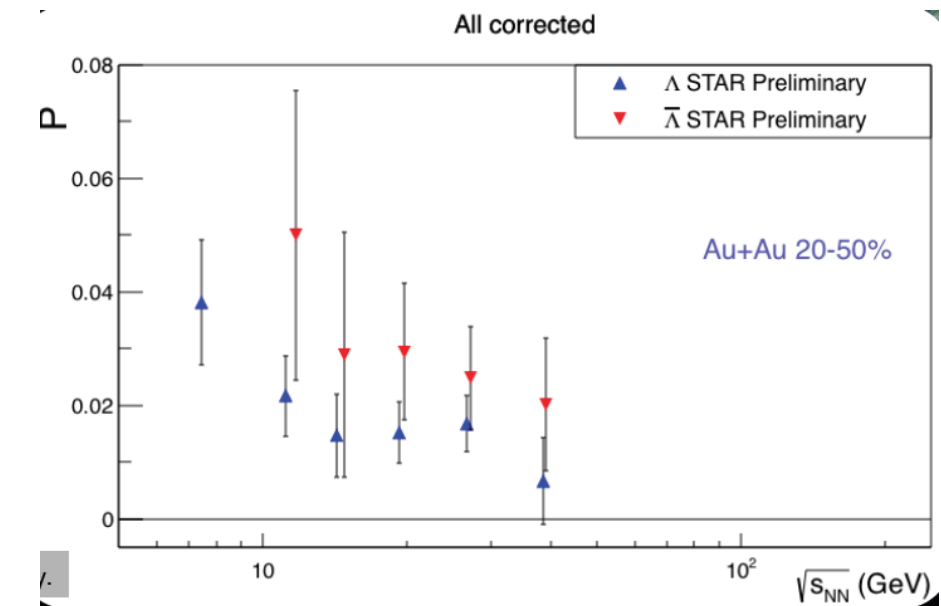
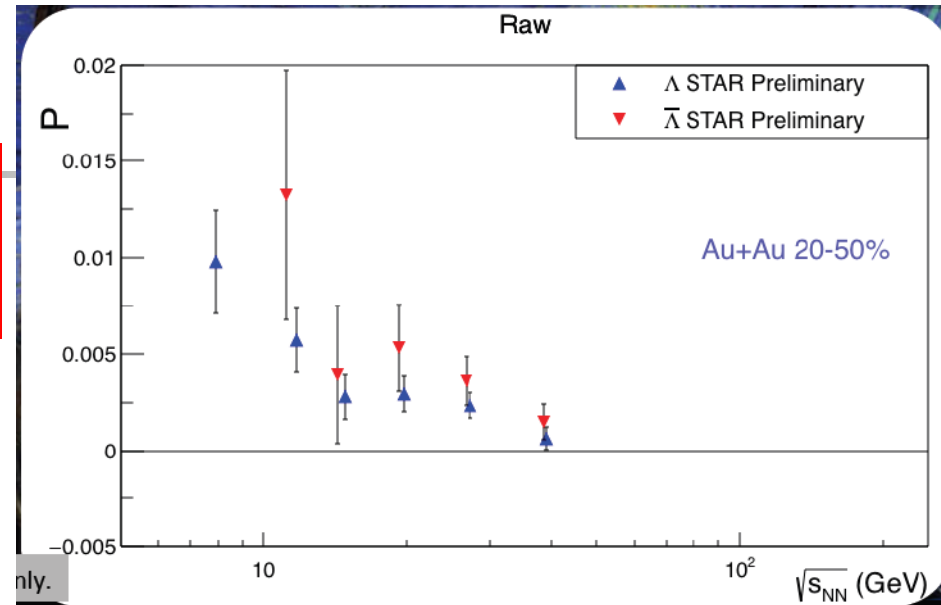



Microworld: where is the fastest possible rotation?

- *Non-central heavy ion collisions (Angular velocity $\sim c/\text{Compton wavelength}$)*
- *~ 25 orders of magnitude faster than Earth's rotation*
- *Differential rotation – vorticity*
- *P-odd : May lead to various P-odd effects*
- *Calculation in kinetic quark - gluon string model (DCM/QGSM) – Boltzmann type eqns + phenomenological string amplitudes):
Baznat, Gudima, Sorin, OT, PRC'13, 16*



Rotation in HIC and related quantities

- *Non-central collisions – orbital angular momentum*
- $L = \Sigma r \times p$
- *Differential pseudovector characteristics – vorticity*
- $\omega = \text{curl } v$
- *Pseudoscalar – helicity*
- $H \sim \langle (v \text{ curl } v) \rangle$
- *Maximal helicity – Beltrami chaotic flows*
 $v \parallel \text{curl } v$

Simulation in QGSM

*(First calculation of **vorticity** in kinetic model;
Baznat, Gudima, Sorin, OT, PRC'13)*

50 × 50 × 100 cells $dx = dy = 0.6 \text{ fm}, dz = 0.6/\gamma \text{ fm}$

- *Velocity*

$$\vec{v}(x, y, z, t) = \frac{\sum_i \sum_j \vec{P}_{ij}}{\sum_i \sum_j E_{ij}}$$

- *Vorticity – from discrete partial derivatives*

Angular momentum conservation and helicity

- *Helicity vs orbital angular momentum (OAM) of fireball*
- *($\sim 10\%$ of total)*

- *Conservation of OAM with a good accuracy!*

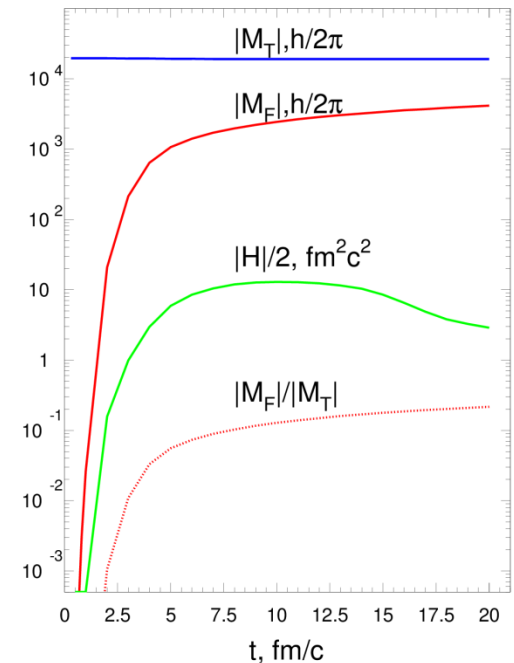

Structure of velocity and vorticity fields (NICA@JINR-5 GeV/c)

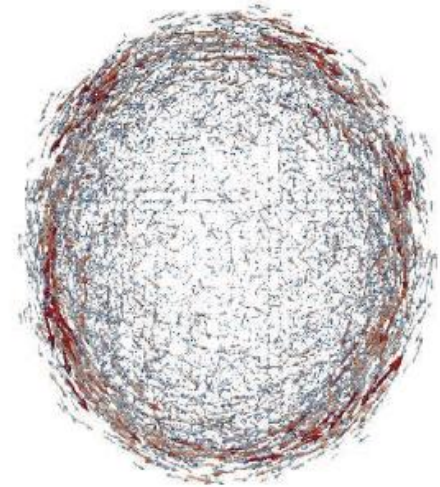
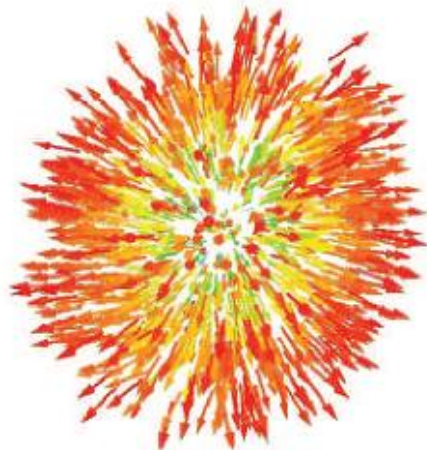
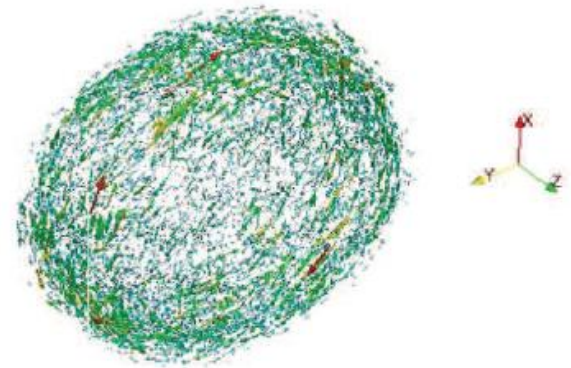
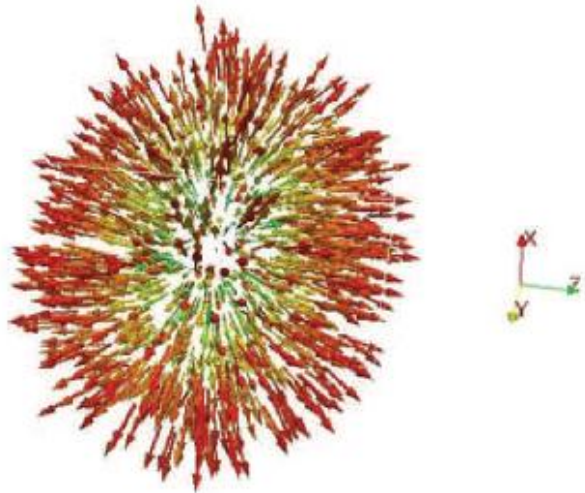

Distribution of velocity ("Little Bang")

- *3D/2D projection*
- *z-beams direction*
- *x-impact parameter*

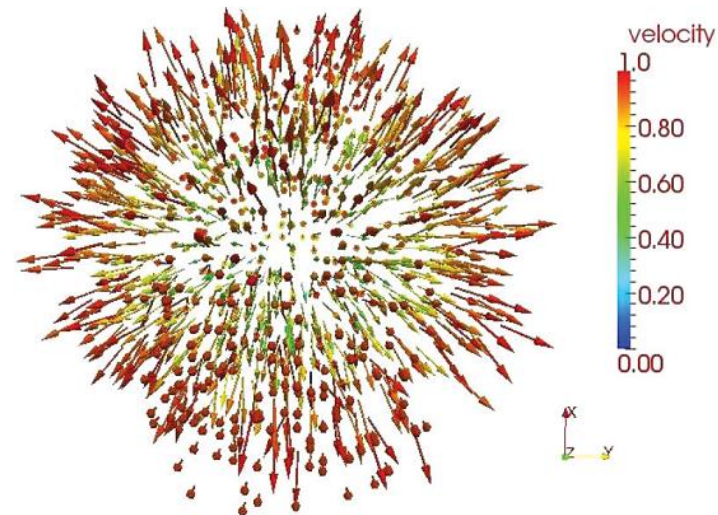
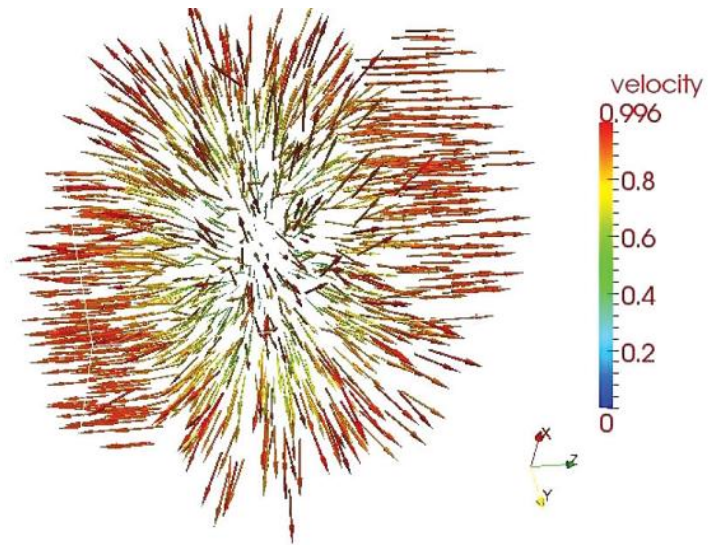

New: "Little Hubble" in PHSD (Baznat, Sorin, OT, Zinchenko, in progress)

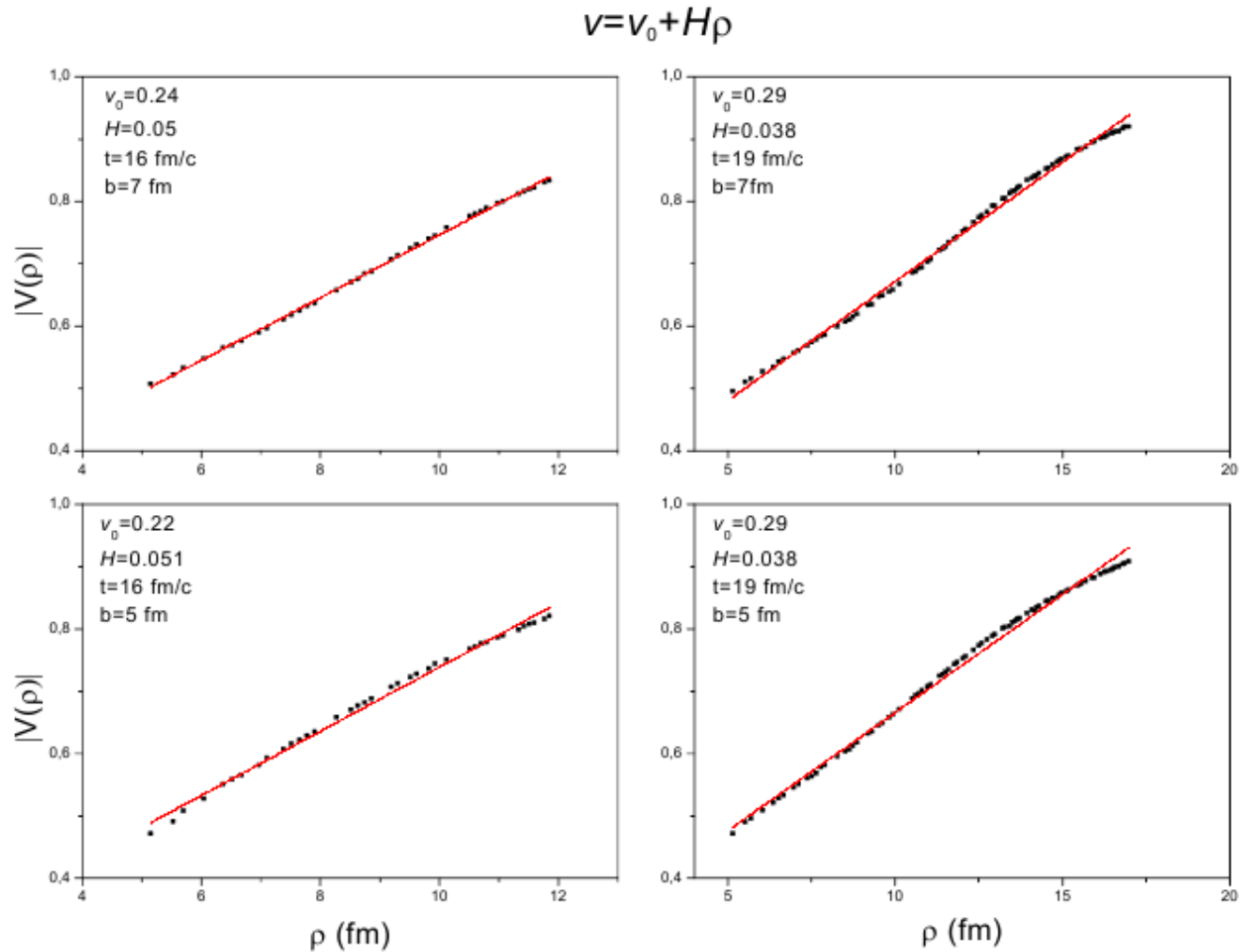

Distribution of vorticity ("Femto-cyclones", "Little galaxies")

- *Layer (on core - corona borderline) patterns*

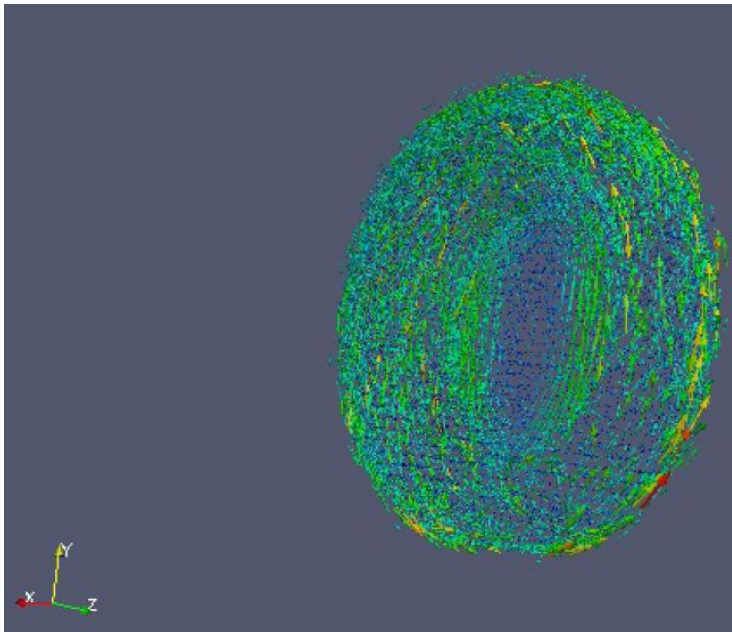
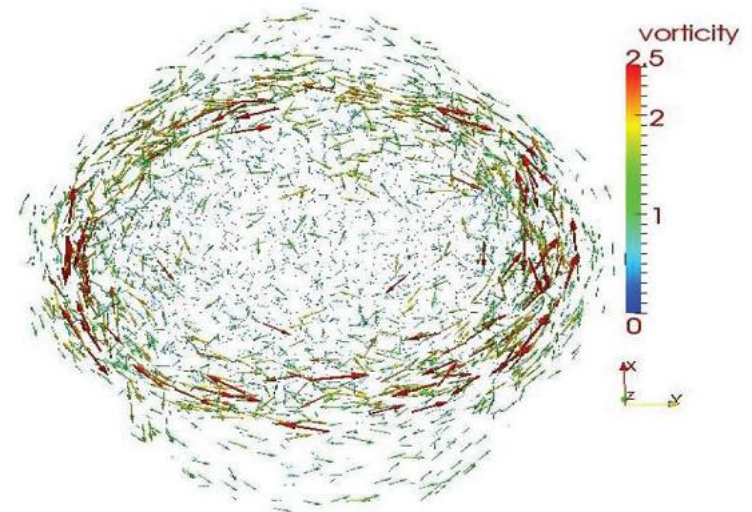
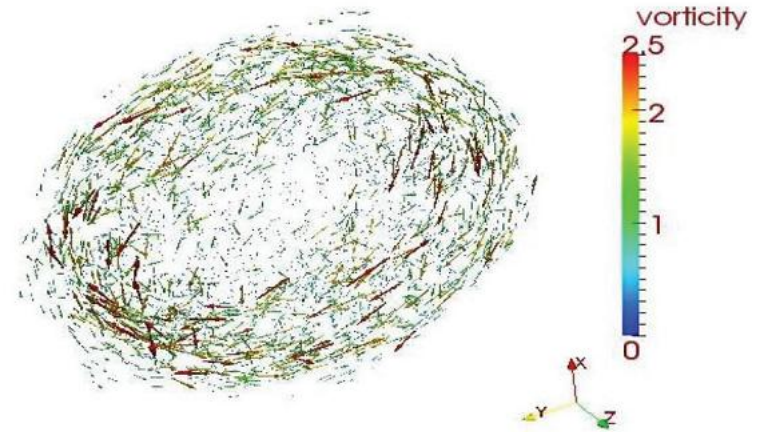

*Vortex sheet (Femto-cyclone)
with fixed direction of L*

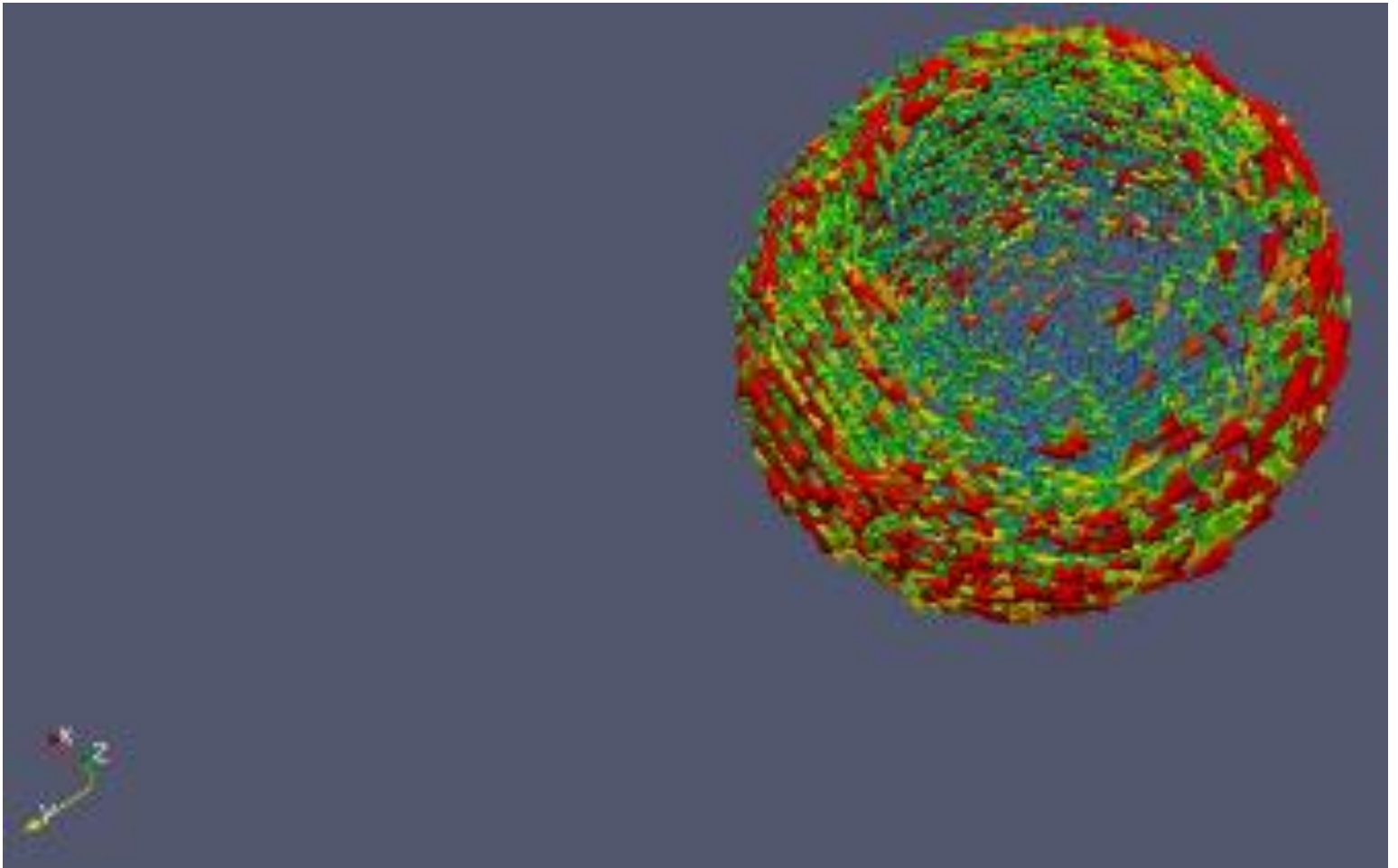

Vortex sheet (Average over L directions)

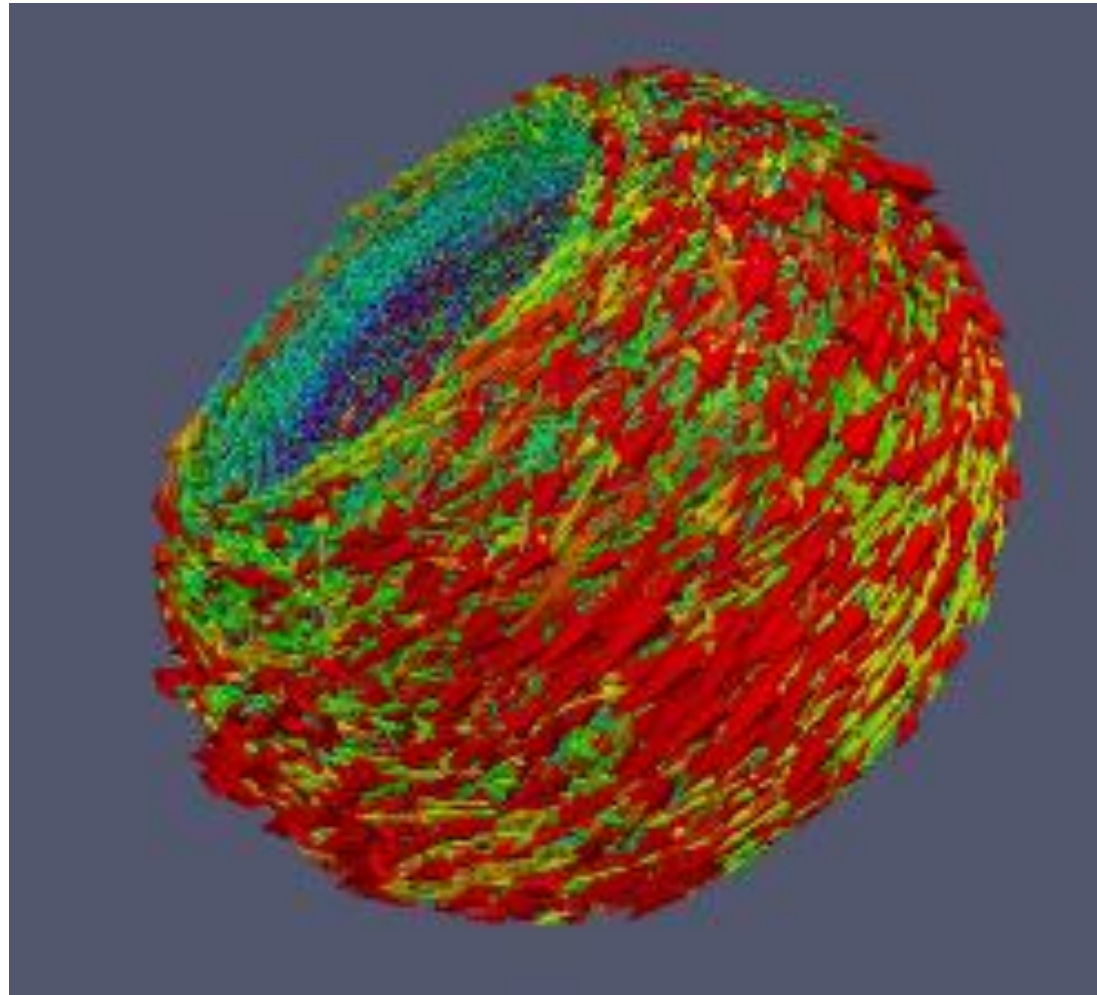

Vortex sheets

- *Naturally appears in kinetic models*
- *Absent in viscous HD (L. Csernai et al)*

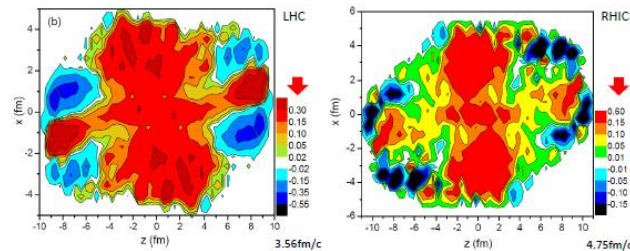

- *Appears in 3 fluid dynamics model (Yu. Ivanov, A. Soldatov, PRC'17)*

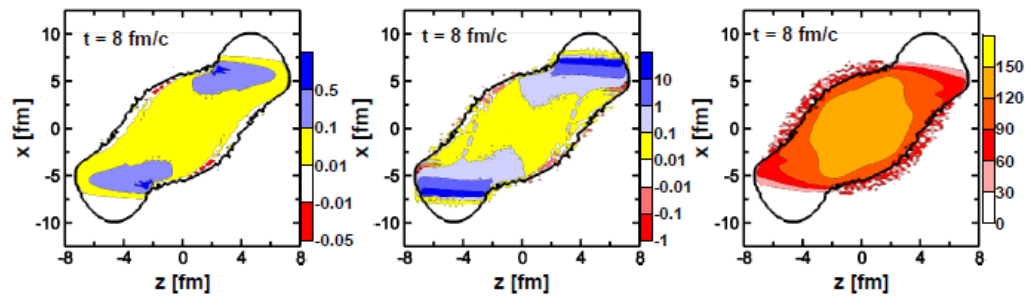

New: Mirror vortex rings in PHSD

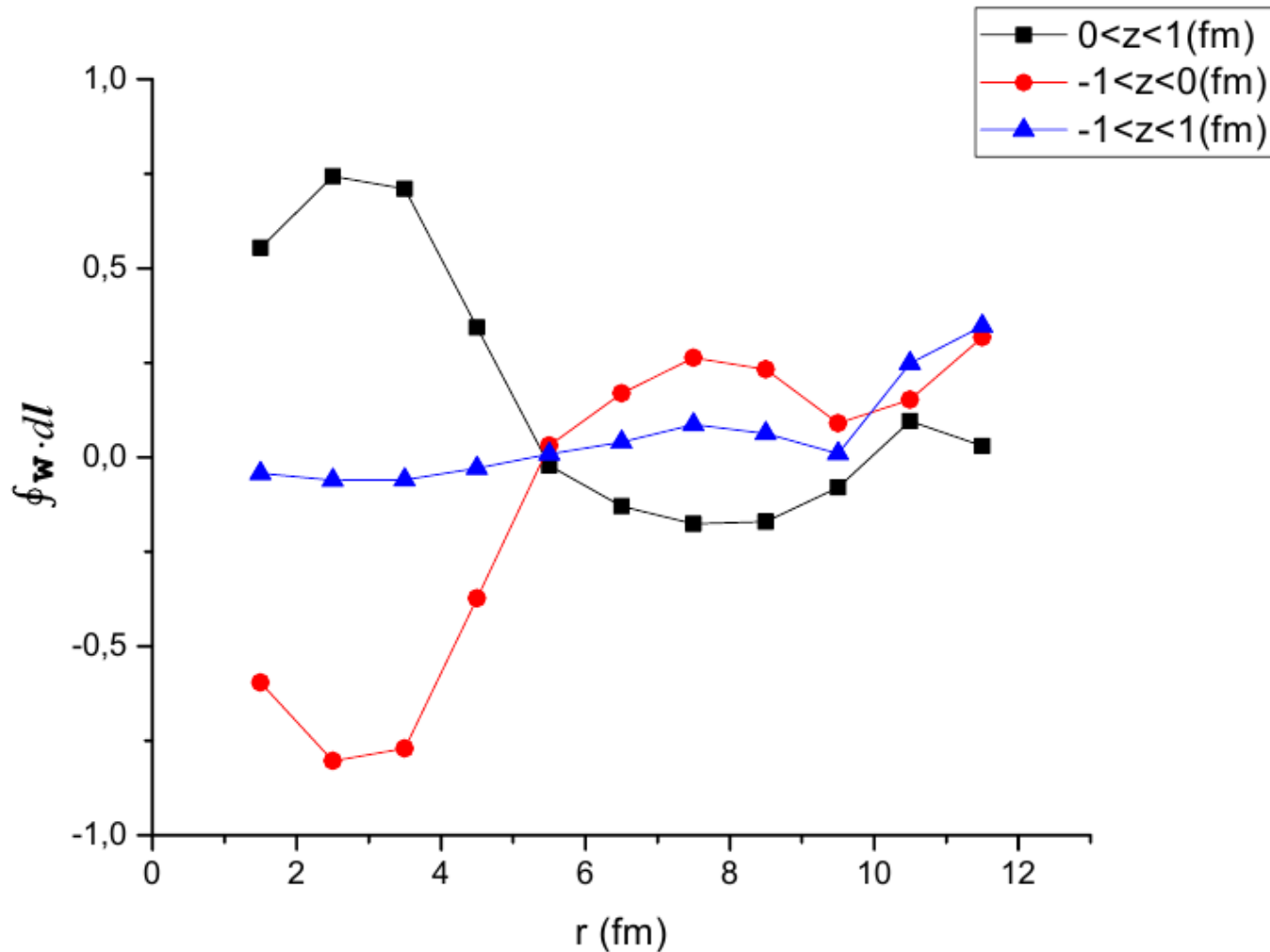

Helicity separation in QGSM

PRC88 (2013) 061901

- *Total helicity integrates to zero BUT*
- *Mirror helicities below and above the reaction plane*
- *Confirmed in HSD (OT, Usubov, PRC92 (2015) 014906*

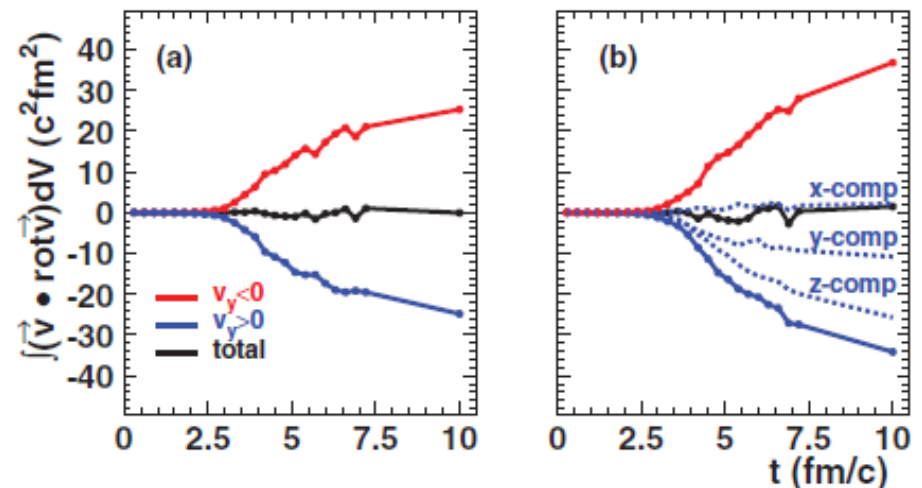

New: Helicity@PHSD

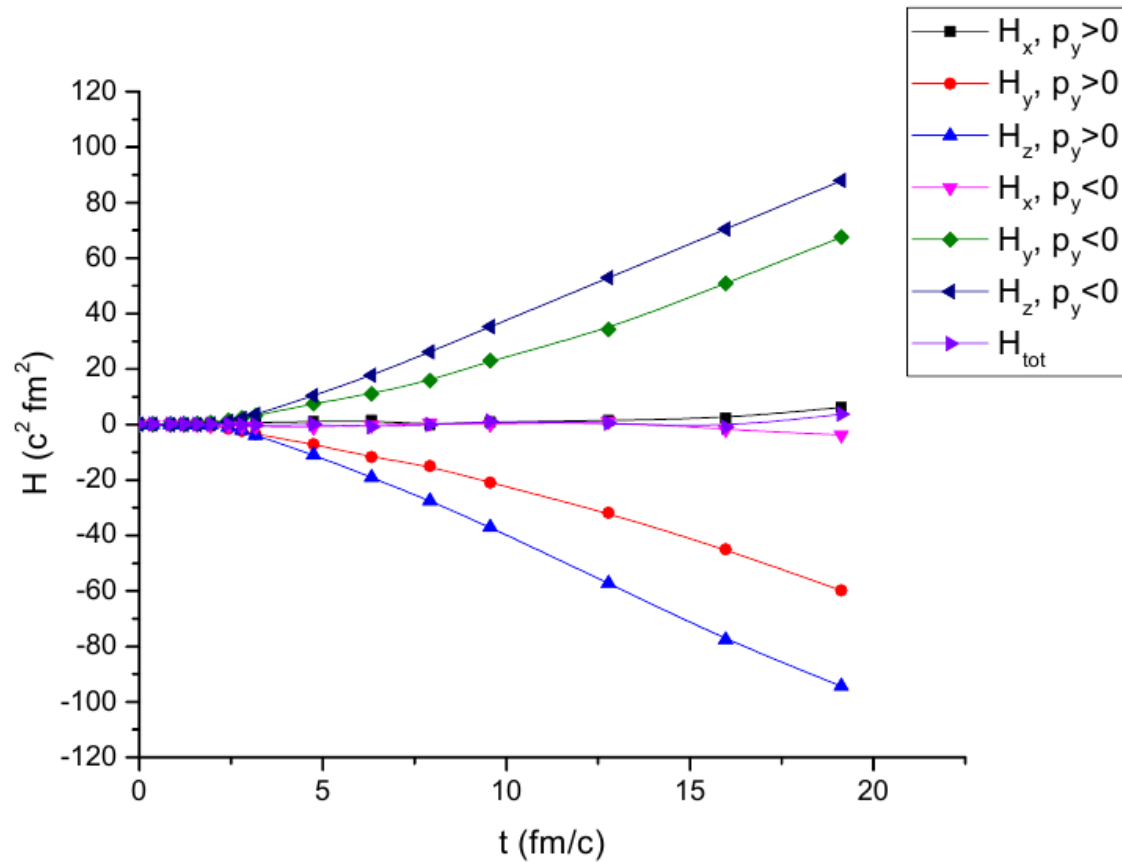

Structure of vorticity (Baznat, Gudima, Sorin, OT'17)

- *y-component: constant vorticity, velocity changes sign*
- ***z-component: quadrupole structure of vorticity***

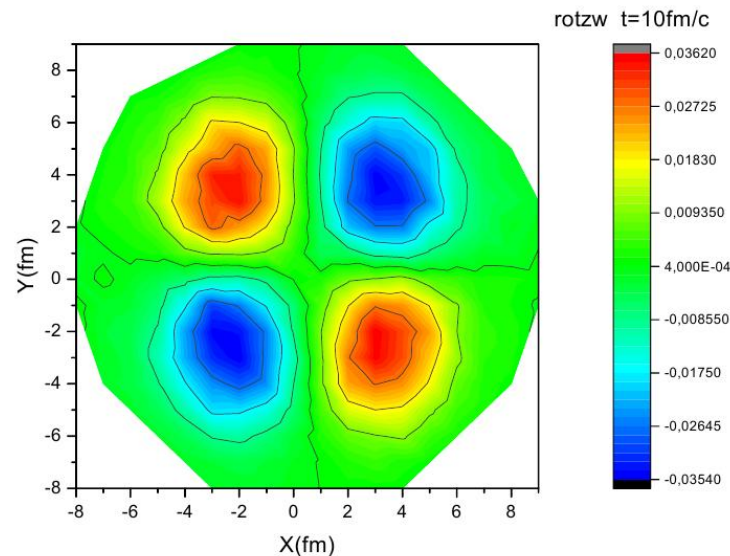

New: PHSD: 2nd Quadrupole Structure

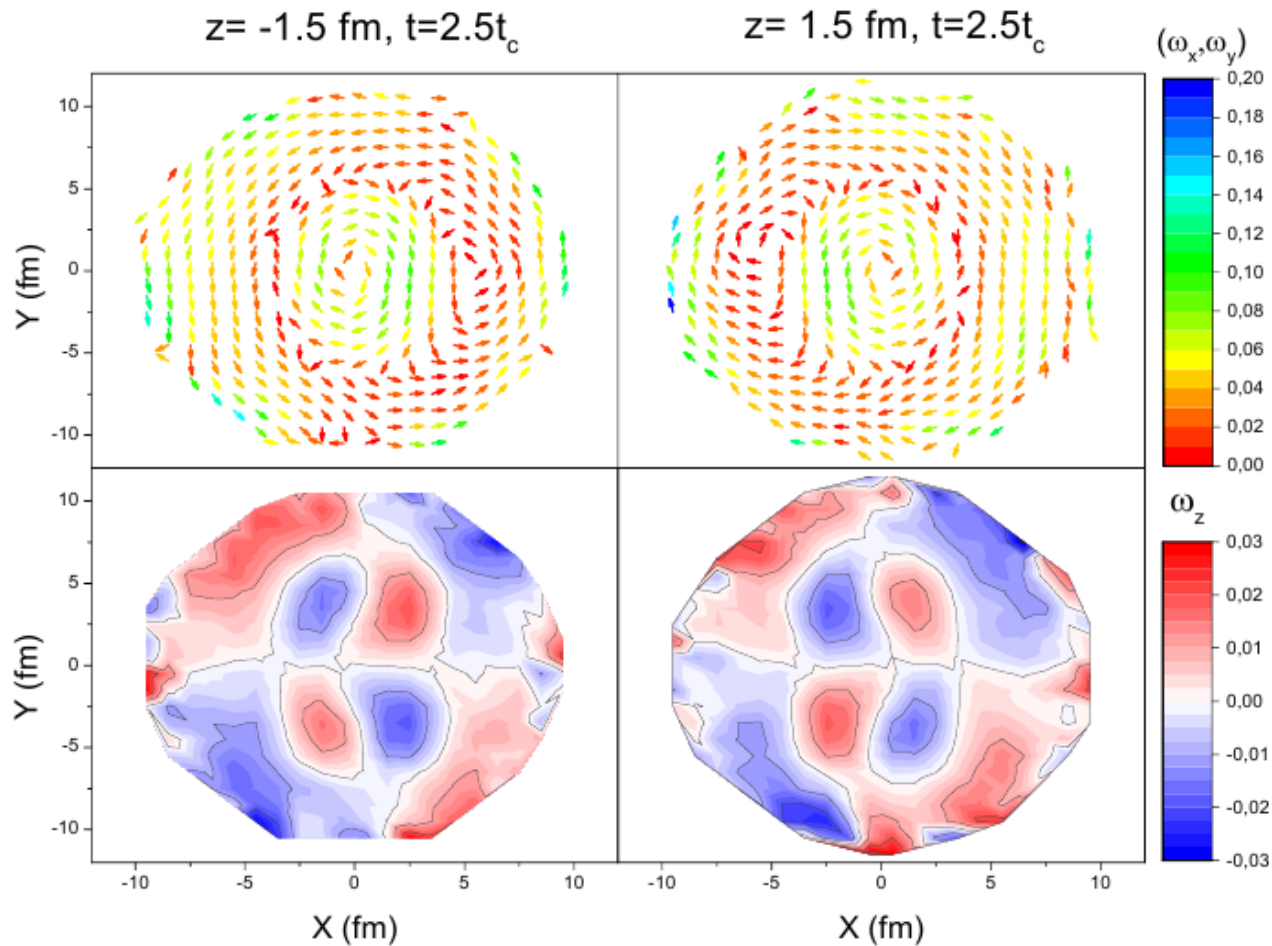

New: XZ- structure of helicity and polarization

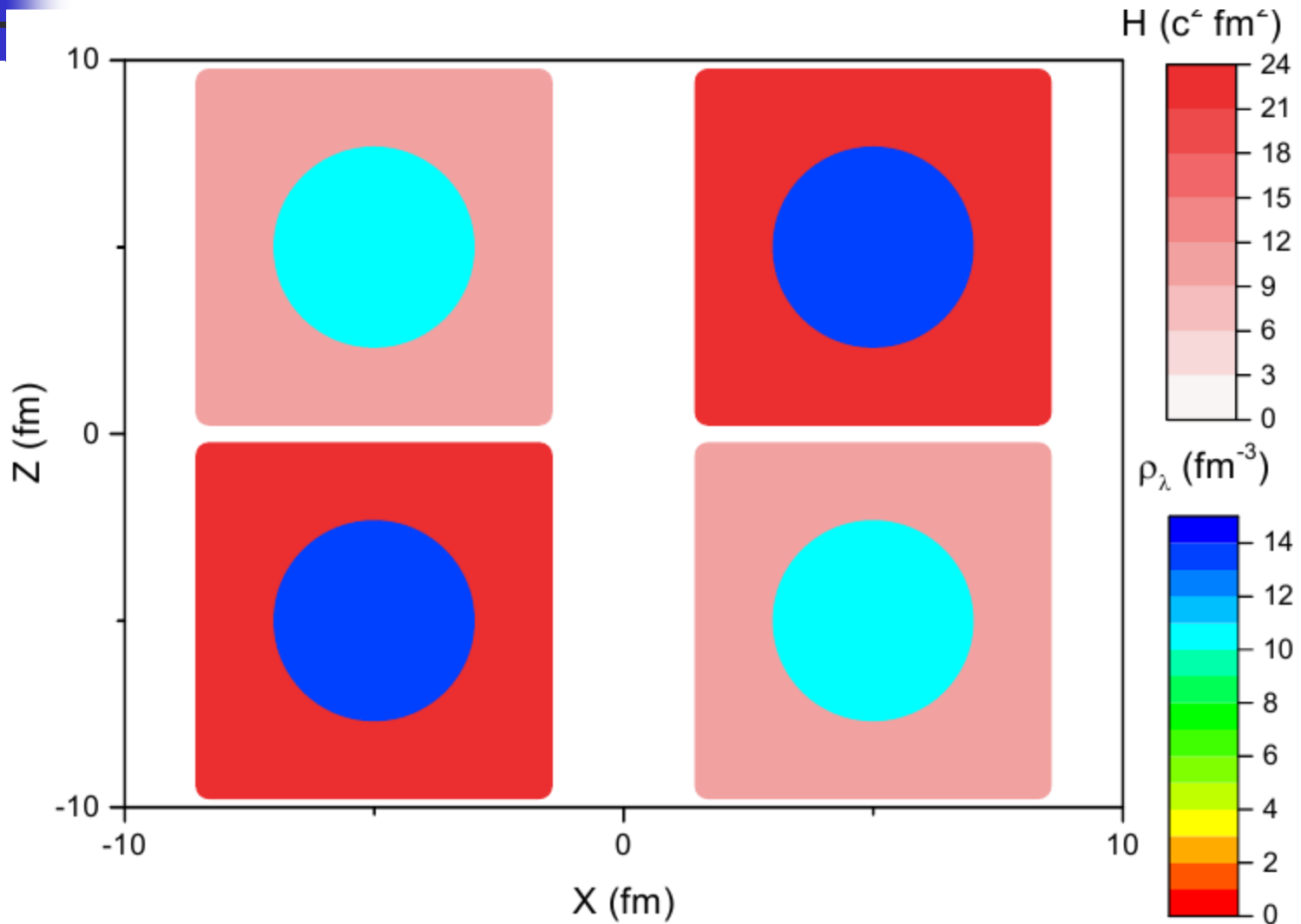

Chemical potential : Kinetics

-> TD

- *TD and chemical equilibrium*
- *Conservation laws*
- *Chemical potential from equilibrium distribution functions*
- *2d section: $y=0$*

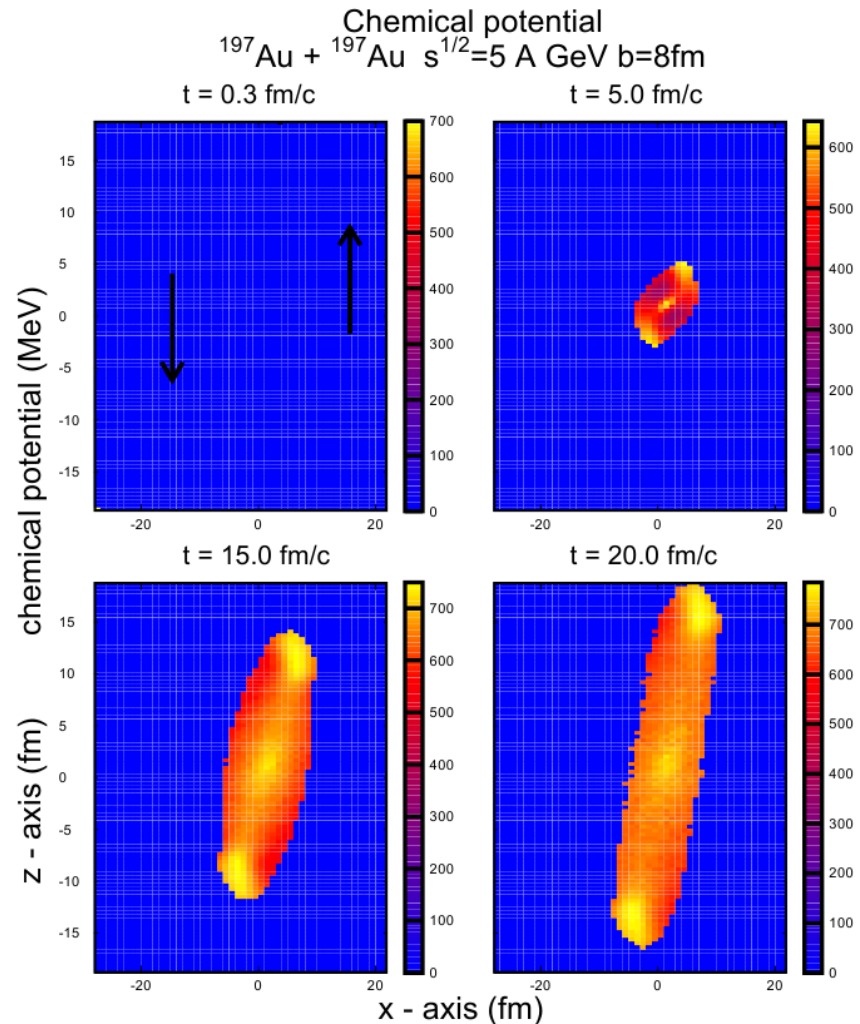

Temperature

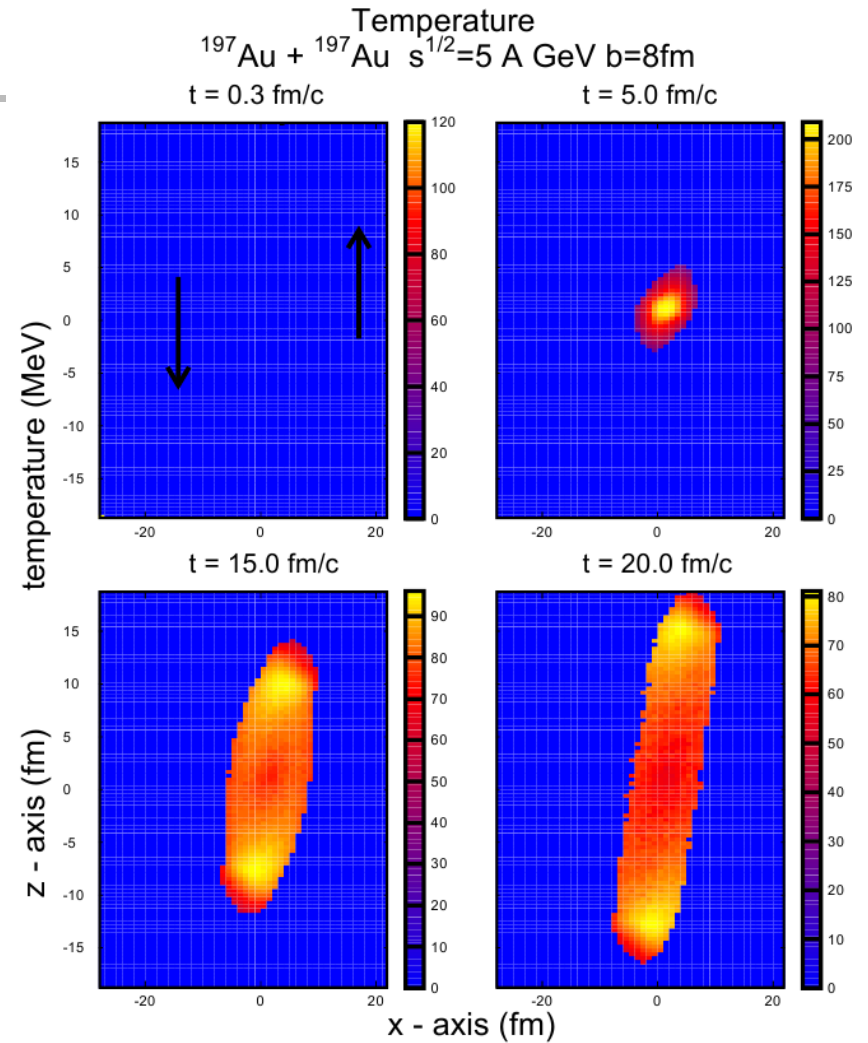

*From **axial charge** (analog of Cooper-Frye) to polarization and from quarks to confined hadrons (Sorin, OT'17)*

- *Analogy of matrix elements and classical averages*

$$\langle p_n | j^0(0) | p_n \rangle = 2p_n^0 Q_n \quad \langle Q \rangle \equiv \frac{\sum_{n=1}^N Q_n}{N} = \frac{\int d^3x j_{class}^0(x)}{N}$$

- *Axial current: charge \rightarrow polarization vector*
- *Lorentz boost: compensates the sign change of helicity "below" and "above" the RP*

$$\Pi^{\Lambda, lab} = (\Pi_0^{\Lambda, lab}, \Pi_x^{\Lambda, lab}, \Pi_y^{\Lambda, lab}, \Pi_z^{\Lambda, lab}) = \frac{\Pi_0^\Lambda}{m_\Lambda} (p_y, 0, p_0, 0)$$

$$\langle \Pi_0^\Lambda \rangle = \frac{m_\Lambda \Pi_0^{\Lambda, lab}}{p_y} = \langle \frac{m_\Lambda}{N_\Lambda p_y} \rangle Q_5^s \equiv \langle \frac{m_\Lambda}{N_\Lambda p_y} \rangle \frac{N_c}{2\pi^2} \int d^3x \mu_s^2(x) \gamma^2 \epsilon^{ijk} v_i \partial_j v_k$$

Axial charge and properties of polarization



- *Antihyperons : same sign (C-even axial charge) and larger value (smaller N)*
- *More pronounced at lower energy.
Baryon/antibaryon splitting due to magnetic field – increase (?!) with energy. Non-linear effects in H may be essential, cf vector mesons on the lattice: Luschevskaya*, Solovjeva, OT: **JHEP 1709 (2017) 142***

***RFBR Megascience program**



Lambda vs Antilambda and role of vector mesons

- *Difference at low energies too large – same axial charge carried by **much** smaller number*
- *Strange axial charge may be also carried by K^* mesons*
- *Λ - accompanied by (+,anti 0) K^* mesons with two sea quarks – small corrections*
- *Anti Λ – more numerous (-,0) K^* mesons with single (sea) strange antiquark*
- *Dominance of one component of spin results also in tensor polarization (P-even source like H^2 : implied by positivity for large polarization) – revealed in dilepton anisotropies (Bratkovskaya, Toneev, OT'95)*



Chemical potential and flavour dependence

- *Way via axial current/charge (TD: chemical potential) differs from "direct" TD (F. Becattini et al.: also for **orbital**/spin momentum; problems with symmetric EMT)*
- *TD-Universal, "flavor-blind" (only mass-dependent) polarization of **universal** sign*
- *Axial current: polarization depends on baryon structure*
- *Most pronounced at low energies*
- *Comparison of hyperons polarization (c.f. hadronic collisions)*

Axial current in TD approach: Role of mass effects (Prokhorov, OT, Zakharov, PRD98 (2018), 071901)

- *Threshold effects in chemical potential and angular velocity; 1906.03529: acceleration (important for longitudinal polarization)*

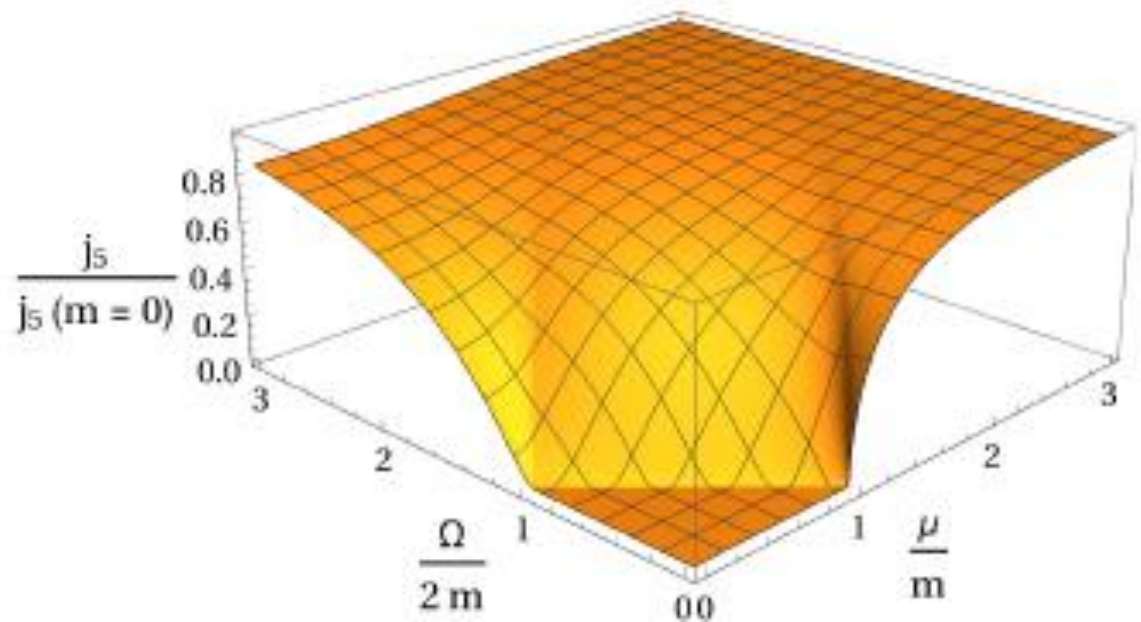

The role of (gravitational anomaly related) T^2 term

- *Different values of coefficient probed*

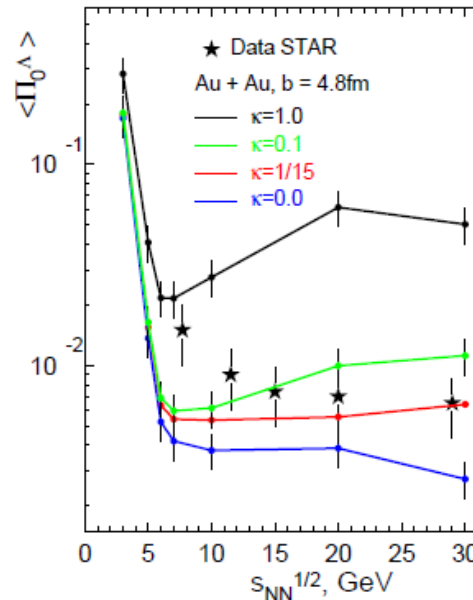

- *LQCD suppression by collective effects supported*

Λ vs Anti Λ

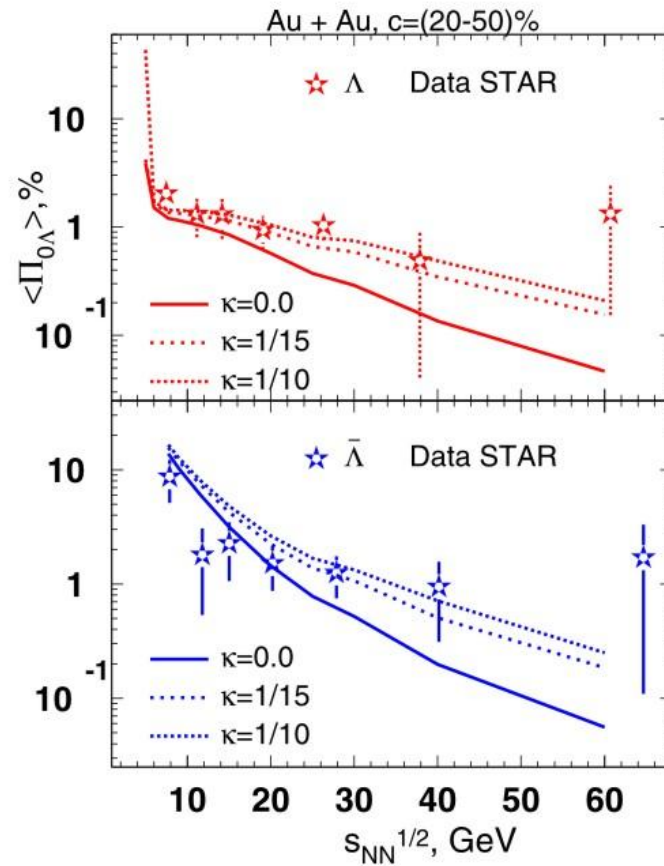

Polarization at NICA/MPD *(A. Kechechyan)*

- *QGSM Simulations and **recovery** accounting for MPD acceptance effects*

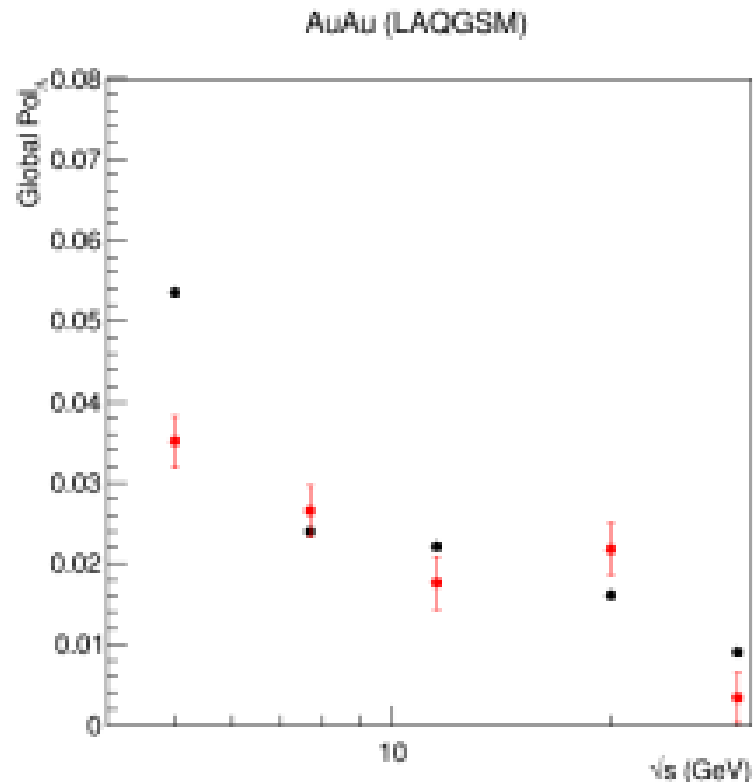



Conclusions

- *Anomaly induced polarization: energy dependence predicted and confirmed*
- *Gravity anomaly contributes in large energy limit*
- *Femtoscopic vortical structures emerge: conformity of Nature at very large range of scales*
- *Interplay with TD mechanism: details to be studied in flavour dependence*



Outlook

- *Studies of vorticity in various models (Hydro, PHSD, UrQMD,...)-
> MPD Root*
- *Comparison of TD and anomalous mechanisms*
- *Interplay with inertial effects (Unruh radiation etc.)*
- *Interplay of inverse vorticity/femtoscscopy radii*
- *Polarization in pp,dp,pA,AA – small systems: cf **Decrease of polarization with energy in Regge theory (cuts)**. Relation to SPD program*
- *Polarization at HADES -> Theory for lower energy and **test@(BM@N)***
- ***Start of activity in studies of vorticity and hyperon polarization in the framefwork of MPD PWG3***



BACKUP



Tensor polarization

- *P-even: quadratic effect of vorticity and/or magnetic field (tensor polarizability)*
- *Lattice: low invariant mass- longitudinal polarization (Buividovich, Polikarpov, OT'12)*
- *Lattice for vector mesons - non-trivial dependence on magnetic field (Lushevskaya, Slojeva, OT'16)*

Tensor polarization@ALICE

- *Protons vs heavy ions*

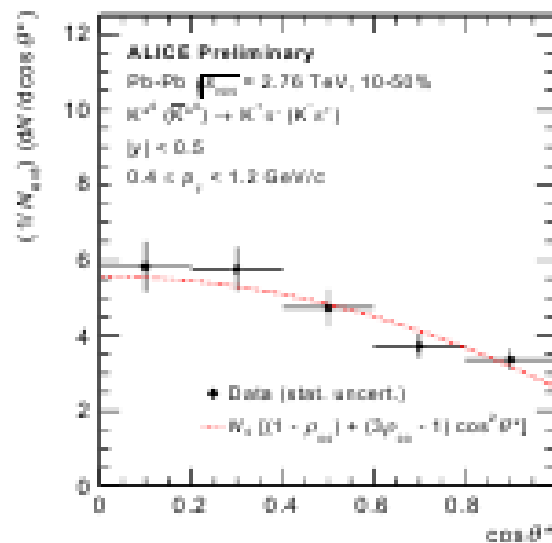
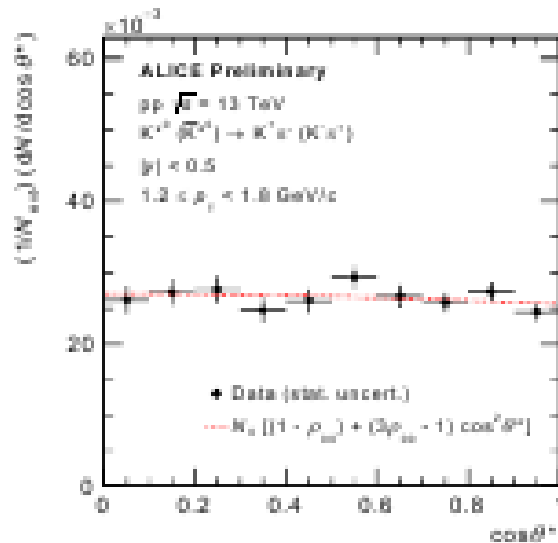

- *Large energy - magnetic field effect?*

Polar and azimuthal asymmetries: kinematically related

Only polar

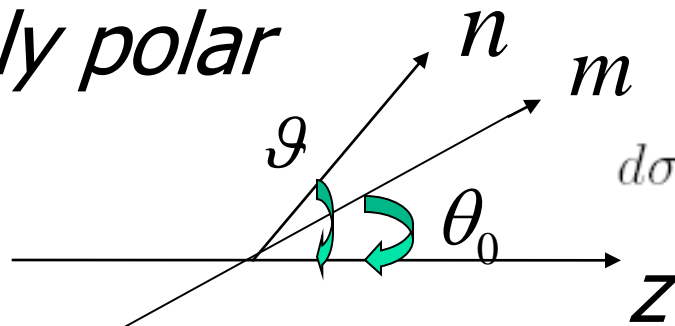

$$d\sigma \propto 1 + \lambda_0 (\vec{n}\vec{m})^2 = 1 + \lambda_0 \cos^2 \theta_{nm}^2$$

asymmetry with respect to m!

$$\cos \theta_{nm} = \cos \theta \cos \theta_0 + \sin \theta \sin \theta_0 \cos \phi$$

- azimuthal

*angle dependence
appears with new*

$$\lambda = \lambda_0 \frac{2 - 3 \sin^2 \theta_0}{2 + \lambda_0 \sin^2 \theta_0}$$

$$\nu = \lambda_0 \frac{2 \sin^2 \theta_0}{2 + \lambda_0 \sin^2 \theta_0}$$

Generalized Lam-Tung relation

(OT'05)



- *Relation between coefficients (high school math sufficient!)*

$$\lambda_0 = \frac{\lambda + \frac{3}{2}\nu}{1 - \frac{1}{2}\nu}$$

- *Reduced to standard LT relation for transverse polarization ($\lambda_0 = 1$)*
- *LT - contains two very different inputs: kinematical asymmetry+transverse polarization*



Properties of GLT

- *Provides rotation-invariant observable (Faccioli, Lourenco, Seixas'10)*
- *Unknown collision axis – non-coplanarity (Peng, Chang, McClellan, OT'15, talk of W.-C. Chang) – violation of LT even for $\lambda_0=1$*
- *Quarkonia production, HIC... – different λ_0*
- *HIC – two natural axes: momentum direction in medium rest frame and normal to reaction plane – extra non-coplanarity appears if reaction plane is known only approximately*



Conclusions/Outlook

- *Polarization – new probe of anomaly (analogous to gluon polarization in nucleon) in quark-gluon matter: to be studied at NICA*
- *Generated by femto-vortex sheets*
- *Energy dependence predicted and confirmed*
- *Same sign and larger magnitude of antihyperon polarization*
- *Polarization - from core of vortices in pionic superfluid*
- *Dileptons – first results – to be compared with hadronic collisions*



Are hadronic and nuclear polarizations so different?

- *Decrease of polarization with energy – natural in Regge theory*
- *Vorticity in $p(\pi p)$ collisions? Angular momentum is smaller, but vorticity is local?*
- *Gauge links with velocity fields?!*
- *.....?!*



Properties of SSA

The same for the case of initial or final state polarization.

Various possibilities to measure the effects: change sign of \vec{n} or \vec{P} : left-right or up-down asymmetry.

Qualitative features of the asymmetry

Transverse momentum required (to have \vec{n})

Transverse polarization (to maximize $(\vec{P}\vec{n})$)

Interference of amplitudes

IMAGINARY phase between amplitudes - absent in Born approximation



Phases and T -oddness

Clearly seen in relativistic approach:

$$\rho = \frac{1}{2}(\hat{p} + m)(1 + \hat{s}\gamma_5)$$

Then: $d\sigma \sim \text{Tr}[\gamma_5 \dots] \sim im\epsilon_{sp_1p_2p_3\dots}$

Imaginary parts (loop amplitudes) are required to produce real observable.

$\epsilon_{abcd} \equiv \epsilon^{\alpha\beta\gamma\delta} a_\alpha b_\beta c_\gamma d_\delta$ each index appears once: P - (compensate S) and T - odd.

However: no real T -violation: interchange $|i\rangle \leftrightarrow |f\rangle$ is the nontrivial operation in the case of nonzero phases of $\langle f|S|i\rangle^* = \langle i|S|f\rangle$.

SSA - either T -violation or the phases.

DIS - no phases ($Q^2 < 0$)- real T -violation.

Correlations of jets handedness

- *LEP – quarks are polarized due to weak interaction*
- *BUT – how to distinguish quark/antiquark jets?*
- *2 jets - correlation of helicities – correlation of handedness*
- *Hadronic collisions – for jets from the same quark-antiquark pair*

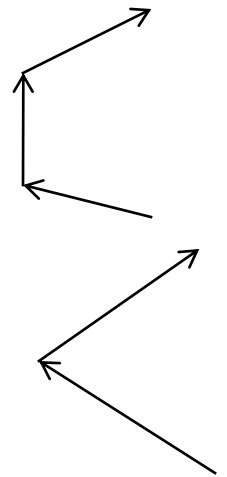

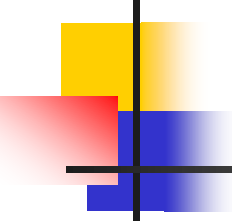

Spin-gravity/rotation (~ 25 orders of magnitude slower!) interactions

- *How to describe hadron spin/gravity(inertia) couplings?*
- *Matrix elements of Energy-Momentum Tensor*
- *May be studied in non-gravitational experiments/theory*
- *Simple interpretation in comparison to EM field case*



Gravitational Formfactors

$$\langle p' | T_{q,g}^{\mu\nu} | p \rangle = \bar{u}(p') \left[A_{q,g}(\Delta^2) \gamma^{(\mu} p^{\nu)} + B_{q,g}(\Delta^2) P^{(\mu} i \sigma^{\nu)\alpha} \Delta_\alpha / 2M \right] u(p)$$

- *Conservation laws - zero Anomalous Gravitomagnetic Moment : $\mu_G = J$ ($g=2$)*

$$P_{q,g} = A_{q,g}(0) \quad A_q(0) + A_g(0) = 1$$

$$J_{q,g} = \frac{1}{2} [A_{q,g}(0) + B_{q,g}(0)] \quad A_q(0) + B_q(0) + A_g(0) + B_g(0) = 1$$

- *May be extracted from high-energy experiments/NPQCD calculations*
- *Describe the partition of angular momentum between quarks and gluons*
- *Describe interaction with both classical and TeV gravity*

Generalized Parton Diistributions (related to matrix elements of non local operators) – models for both EM and Gravitational Formfactors (Selyugin, OT '09)

- *Smaller mass square radius (attraction vs repulsion!?)*

$$\rho(b) = \sum_q e_q \int dx q(x, b) = \int d^2 q F_1(Q^2 = q^2) e^{i\vec{q}\vec{b}}$$

$$= \int_0^\infty \frac{q dq}{2\pi} J_0(qb) \frac{G_E(q^2) + \tau G_M(q^2)}{1 + \tau}$$

$$\rho_0^{\text{Gr}}(b) = \frac{1}{2\pi} \int_0^\infty dq q J_0(qb) A(q^2)$$

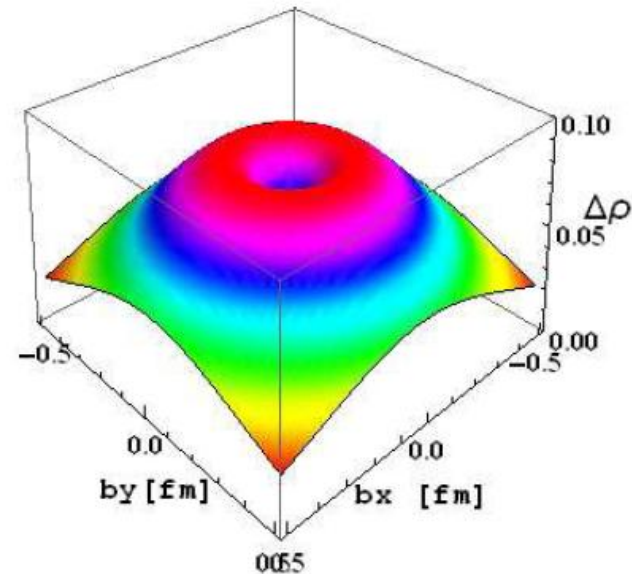

FIG. 17: Difference in the forms of charge density F_1^P and "matter" density (A)



Electromagnetism vs Gravity

- *Interaction – field vs metric deviation*

$$M = \langle P' | J_q^\mu | P \rangle A_\mu(q) \qquad M = \frac{1}{2} \sum_{q,G} \langle P' | T_{q,G}^{\mu\nu} | P \rangle h_{\mu\nu}(q)$$

- *Static limit*

$$\langle P | J_q^\mu | P \rangle = 2e_q P^\mu \qquad \sum_{q,G} \langle P | T_i^{\mu\nu} | P \rangle = 2P^\mu P^\nu$$
$$h_{00} = 2\phi(x)$$

$$M_0 = \langle P | J_q^\mu | P \rangle A_\mu = 2e_q M \phi(q) \qquad M_0 = \frac{1}{2} \sum_{q,G} \langle P | T_i^{\mu\nu} | P \rangle h_{\mu\nu} = 2M \cdot M \phi(q)$$

- *Mass as charge – equivalence principle
(Einstein '10-11, Praha)*



Equivalence principle

- *Newtonian – "Falling elevator" – well known and checked with high accuracy (also for elementary particles)*
- *Post-Newtonian – gravity action on SPIN – known since 1962 (Kobzarev and Okun' ZhETF paper contains acknowledgment to Landau: probably his last contribution to theoretical physics before car accident); rederived from conservation laws - Kobzarev and Zakharov*
- *Anomalous gravitomagnetic (and electric-CP-odd) moment is ZERO or*
- *Classical and QUANTUM rotators behave in the SAME way*
- *For GEDM –checked with sometimes controversial results*
- *For AGM not checked on purpose but in fact checked in the same atomic spins experiments at % level (Silenko, OT'07)*



Gravitomagnetism

- *Gravitomagnetic field (weak, except in gravity waves) – action on spin from*
$$M = \frac{1}{2} \sum_{q,G} \langle P' | T_{q,G}^{\mu\nu} | P \rangle h_{\mu\nu}(q)$$

$$\vec{H}_J = \frac{1}{2} \text{rot} \vec{g}; \quad \vec{g}_i \equiv g_{0i}$$

*spin dragging twice
smaller than EM*

- *Lorentz force – similar to EM case: factor 1/2 cancelled with 2 from frequency same as EM*

$$h_{00} = 2\phi(x)$$

Larmor

$$\omega_J = \frac{\mu_G}{J} H_J = \frac{H_L}{2} = \omega_L \quad \vec{H}_L = \text{rot} \vec{g}$$

- *Orbital and Spin momenta dragging – the same - Equivalence principle*



Experimental test of PNEP

- *Reinterpretation of the data on $G(\text{EDM})$ search*

PHYSICAL REVIEW
LETTERS

VOLUME 68

13 JANUARY 1992

NUMBER 2

Search for a Coupling of the Earth's Gravitational Field to Nuclear Spins in Atomic Mercury

B. J. Venema, P. K. Majumder, S. K. Lamoreaux, B. R. Heckel, and E. N. Fortson

Physics Department, FM-15, University of Washington, Seattle, Washington 98195
(Received 25 September 1991)

- *If (CP-odd!) $G_{\text{EDM}}=0 \rightarrow$ constraint for AGM (Silenko, OT'07) from Earth rotation – was considered as obvious (but it is just EP!) background*

$$\mathcal{H} = -g\mu_N \mathbf{B} \cdot \mathbf{S} - \zeta \hbar \boldsymbol{\omega} \cdot \mathbf{S}, \quad \zeta = 1 + \chi$$

$$|\chi(^{201}\text{Hg}) + 0.369\chi(^{199}\text{Hg})| < 0.042 \quad (95\% \text{C.L.})$$

Equivalence principle for moving particles

- *Compare gravity and acceleration: gravity provides EXTRA space components of metrics* $h_{zz} = h_{xx} = h_{yy} = h_{00}$

- *Matrix elements DIFFER*

$$\mathcal{M}_g = (\epsilon^2 + p^2)h_{00}(q), \quad \mathcal{M}_a = \epsilon^2 h_{00}(q)$$

- *Ratio of accelerations: $R = \frac{\epsilon^2 + p^2}{\epsilon^2}$ - confirmed by explicit solution of Dirac equation (Silenko, OT, '05)*
- *Arbitrary fields – Obukhov, Silenko, OT '09,'11,'13*



Gravity vs accelerated frame for spin and helicity

- *Spin precession – well known factor 3 (Probe B; spin at satellite – probe of PNEP!) – smallness of relativistic correction ($\sim \mathbf{P}^2$) is compensated by $1/\mathbf{P}^2$ in the momentum direction precession frequency*
- *Helicity flip – the same!*
- *No helicity flip in gravitomagnetic field – another formulation of PNEP (OT'99)*



Gyromagnetic and Gravigyromagnetic ratios

- *Free particles – coincide*
- $\langle P+q|T^{mn}|P-q\rangle = P^{\{m}\langle P+q|J^{n\}}|P-q\rangle/e$ up to the terms linear in q
- *Special role of $g=2$ for any spin (asymptotic freedom for vector bosons)*
- *Should Einstein know about PNEP, the outcome of his and de Haas experiment would not be so surprising*
- *Recall also $g=2$ for Black Holes. Indication of "quantum" nature?!*

Cosmological implications of PNEP

- *Necessary condition for Mach's Principle (in the spirit of Weinberg's textbook) -*
- *Lense-Thirring inside massive rotating empty shell (=model of Universe)*
- *For **flat** "Universe" - precession frequency equal to that of shell rotation*
- *Simple observation-Must be the same for classical and **quantum** rotators – PNEP!*
- *More elaborate models - Tests for cosmology ?!*

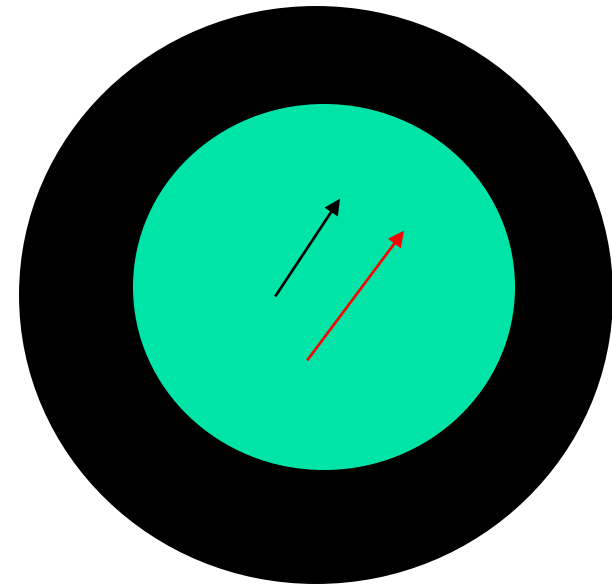

Torsion – acts only on spin (violates EP)

Dirac eq+FW transformation-Obukhov,Silenko,OT, [arXiv:1410.6197](https://arxiv.org/abs/1410.6197)

■ *Hermitian Dirac Hamiltonian*

$$e_i^{\hat{0}} = V \delta_i^0, \quad e_i^{\hat{a}} = W^{\hat{a}}_b (\delta_i^b - cK^b \delta_i^0) \quad \mathcal{H} = \beta mc^2 V + q\Phi + \frac{c}{2} (\pi_b \mathcal{F}^b_a \alpha^a + \alpha^a \mathcal{F}^b_a \pi_b)$$

$$ds^2 = V^2 c^2 dt^2 - \delta_{\hat{a}\hat{b}} W^{\hat{a}}_c W^{\hat{b}}_d (dx^c - K^c c dt)(dx^d - K^d c dt) \quad + \frac{c}{2} (\mathbf{K} \cdot \boldsymbol{\pi} + \boldsymbol{\pi} \cdot \mathbf{K}) + \frac{\hbar c}{4} (\boldsymbol{\Xi} \cdot \boldsymbol{\Sigma} - \Upsilon \gamma_5),$$

$$\mathcal{F}^b_a = V W^b_{\hat{a}}, \quad \Upsilon = V \epsilon^{\hat{a}\hat{b}\hat{c}} \Gamma_{\hat{a}\hat{b}\hat{c}}, \quad \Xi^a = \frac{V}{c} \epsilon^{\hat{a}\hat{b}\hat{c}} (\Gamma_{\hat{0}\hat{b}\hat{c}} + \Gamma_{\hat{b}\hat{c}\hat{0}} + \Gamma_{\hat{c}\hat{0}\hat{b}})$$

■ *Spin-torsion coupling*

$$- \frac{\hbar c V}{4} (\boldsymbol{\Sigma} \cdot \check{\mathbf{T}} + c \gamma_5 \check{T}^{\hat{0}})$$

$$\check{T}^\alpha = - \frac{1}{2} \eta^{\alpha\mu\nu\lambda} T_{\mu\nu\lambda}$$

■ *FW – semiclassical limit - precession*

$$\Omega^{(T)} = - \frac{c}{2} \check{\mathbf{T}} + \beta \frac{c^3}{8} \left\{ \frac{1}{\epsilon'}, \{p, \check{T}^{\hat{0}}\} \right\} + \frac{c}{8} \left\{ \frac{c^2}{\epsilon'(\epsilon' + mc^2)}, (\{p^2, \check{\mathbf{T}}\} - \{p, (p \cdot \check{\mathbf{T}})\}) \right\}$$

Experimental bounds for torsion

- *Magnetic field+rotation+torsion*

$$H = -g_N \frac{\mu_N}{\hbar} \mathbf{B} \cdot \mathbf{s} - \boldsymbol{\omega} \cdot \mathbf{s} - \frac{c}{2} \check{\mathbf{T}} \cdot \mathbf{s},$$

- *Same '92 EDM experiment*

$$\frac{\hbar c}{4} |\check{\mathbf{T}}| \cdot |\cos \Theta| < 2.2 \times 10^{-21} \text{ eV}, \quad |\check{\mathbf{T}}| \cdot |\cos \Theta| < 4.3 \times 10^{-14} \text{ m}^{-1}$$

- *New(based on Gemmel et al '10)*

$$\frac{\hbar c}{2} |\check{\mathbf{T}}| \cdot |(1 - \mathcal{G}) \cos \Theta| < 4.1 \times 10^{-22} \text{ eV}, \quad |\check{\mathbf{T}}| \cdot |\cos \Theta| < 2.4 \times 10^{-15} \text{ m}^{-1},$$
$$\mathcal{G} = g_{He}/g_{Xe}$$

Generalization of Equivalence principle

- *Various arguments: $AGM \approx 0$ separately for quarks and gluons – most clear from the lattice (LHPC/SESAM)*

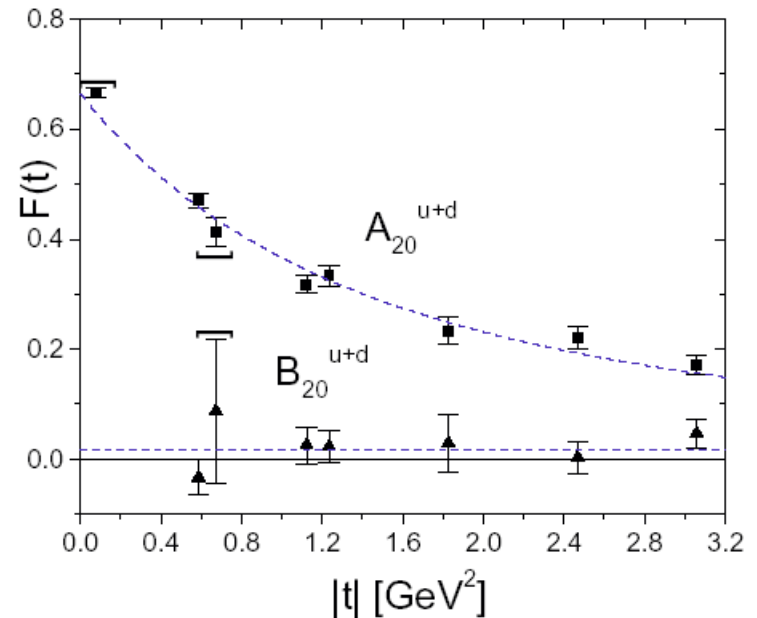
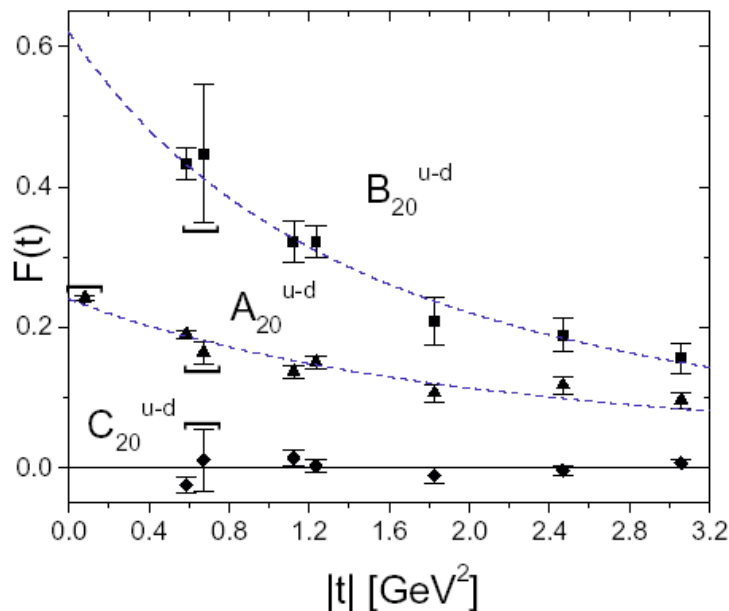

Recent lattice study (M. Deka et al. [arXiv:1312.4816](https://arxiv.org/abs/1312.4816))

- *Sum of u and d for Dirac (T1) and Pauli (T2) FFs*

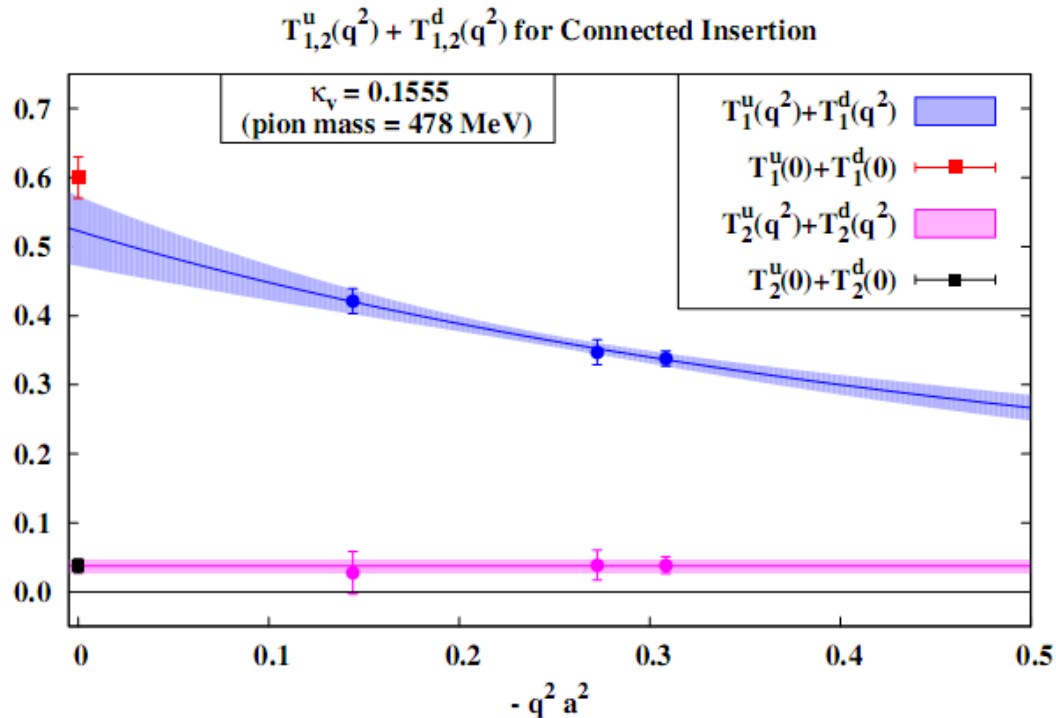

Extended Equivalence

Principle=Exact EquiPartition

- *In pQCD – violated*
- *Reason – in the case of ExEP- no smooth transition for zero fermion mass limit (Milton, 73)*
- *Conjecture (O.T., 2001 – prior to lattice data) – valid in NP QCD – zero quark mass limit is safe due to chiral symmetry breaking*
- *Gravity-proof confinement (should the hadrons survive enetering Black Hole?)?!*

Another manifestation of post-Newtonian (E)EP for spin 1 hadrons

- *Tensor polarization - coupling of gravity to spin in forward matrix elements - inclusive processes*
- *Second moments of tensor distributions should sum to zero*

$$\langle P, S | \bar{\psi}(0) \gamma^\nu D^{\nu_1} \dots D^{\nu_n} \psi(0) | P, S \rangle_{\mu^2} = i^{-n} M^2 S^{\nu\nu_1} P^{\nu_2} \dots P^{\nu_n} \int_0^1 C_q^T(x) x^n dx$$

$$\sum_q \langle P, S | T_i^{\mu\nu} | P, S \rangle_{\mu^2} = 2P^\mu P^\nu (1 - \delta(\mu^2)) + 2M^2 S^{\mu\nu} \delta_1(\mu^2)$$

$$\langle P, S | T_g^{\mu\nu} | P, S \rangle_{\mu^2} = 2P^\mu P^\nu \delta(\mu^2) - 2M^2 S^{\mu\nu} \delta_1(\mu^2)$$

$$\sum_q \int_0^1 C_i^T(x) x dx = \delta_1(\mu^2) = 0 \text{ for ExEP}$$

HERMES – data on tensor spin structure function

PRL 95, 242001 (2005)

- *Isoscalar target – proportional to the sum of u and d quarks – combination required by EEP*
- *Second moments – compatible to zero better than the first one (collective glue \ll sea) – for valence:*

$$\int_0^1 C_i^T(x) dx = 0.$$

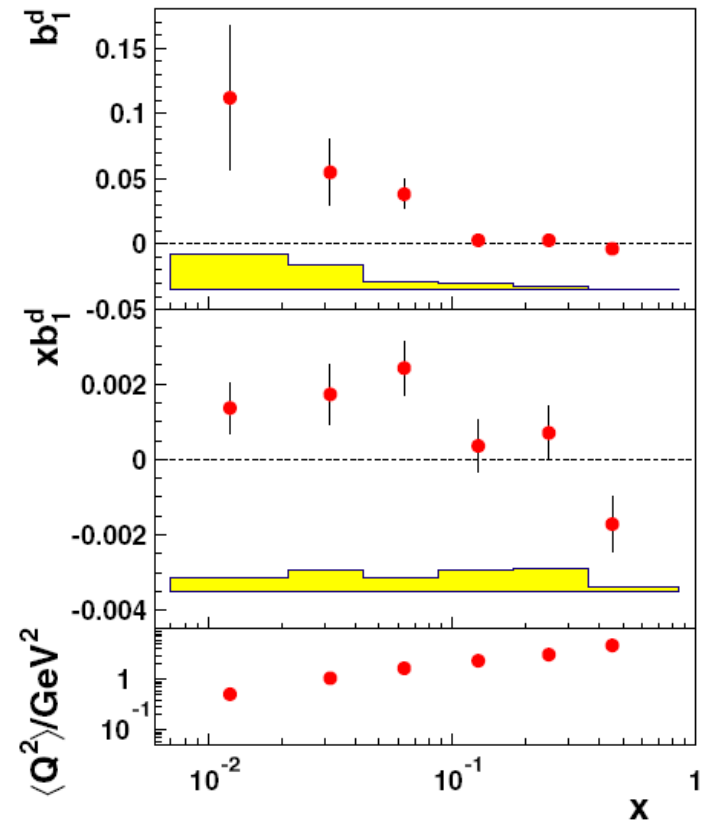



Conclusions (slow rotation)

- *Probe of equivalence principle for spin*
- *May be tested in EDM search experiments*
- *Extension of EP –validity separately for quarks and gluons*



Sum rules for EMT (and OAM)

- *First (seminal) example: X. Ji's sum rule ('96). Gravity counterpart – OT'99*
- *Burkardt sum rule – looks similar: can it be derived from EMT?*
- *Yes, if provide correct prescription to gluonic pole (OT'14)*

Pole prescription and Burkardt

SR

- *Pole prescription (dynamics!) provides ("T-odd") symmetric part!*
- *SR: $\sum \int dx T(x, x) = 0$ $\sum \int \int dx_1 dx_2 \frac{T(x_1, x_2)}{x_1 - x_2 + i\varepsilon} = 0$ (but relation of gluon Sivers to twist 3 still not found – prediction!)*
- *Can it be valid separately for each quark flavour: nodes (related to "sign problem")?*
- *Valid if structures forbidden for TOTAL EMT do not appear for each flavour*
- *Structure contains besides S gauge vector n: If GI separation of EMT – forbidden: SR valid separately!*



Are more accurate data possible?

- *HERMES – unlikely*
- *JLab may provide information about collective sea and glue in deuteron and indirect new test of Equivalence Principle*



CONCLUSIONS

- *Spin-gravity interactions may be probed directly in gravitational (inertial) experiments and indirectly – studying EMT matrix element*
- *Torsion and EP are tested in EDM experiments*
- *SR's for deuteron tensor polarization-indirectly probe EP and its extension separately for quarks and gluons*



EEP and AdS/QCD

- *Recent development – calculation of Rho formfactors in Holographic QCD (Grigoryan, Radyushkin)*
- *Provides $g=2$ identically!*
- *Experimental test at time –like region possible*



Magnetic field?

- *Heavy-ion collisions – fast charged particles - largest ever magnetic field ($\sim m_{\pi}^2$)*
- *Magnetic moment -> polarization*
- *Field is typically **increasing** for large energies but polarization is observed by STAR (**Nature 548 (2017) 62-65**) at **lower** energies!*

Quark-gluon correlators

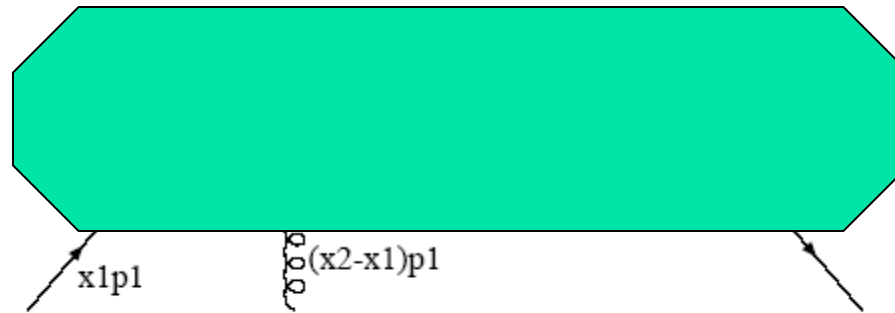

- *Non-perturbative NUCLEON structure – physically mean the quark scattering in external gluon field of the HADRON.*
- *Depend on TWO parton momentum fractions*
- *For small transverse momenta – quark momentum fractions are close to each other- gluonic pole; probed if :*

$$Q \gg P_T \gg M$$

$$x_2 - x_1 = \delta = \frac{P_T^2 x_B}{Q^2 z}$$



Global polarization

- *Global polarization normal to REACTION plane*

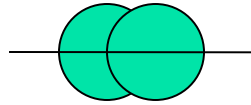

- *Predictions (Z.-T.Liang et al.): large orbital angular momentum -> large polarization*
- *Search by STAR (Selyuzhenkov et al.'07) : polarization NOT found at % level!*
- *Due to locality of LS coupling while large orbital angular momentum is distributed*
- *How to transform rotation to spin?*