



Analysis & Software Meeting of the BM@N Experiment

# Расширение времяпролетной системы TOF400

Румянцев М.М., Бабкин В.А., Буряков М.Г., Бузин С.Г., Дулов П.О.,  
Головатюк В.М., Дмитриев А.В, Маликов И.В., Антонова А.Е.,  
Тимофеев С.В., Тимофеева А.Е.

# Current Configuration

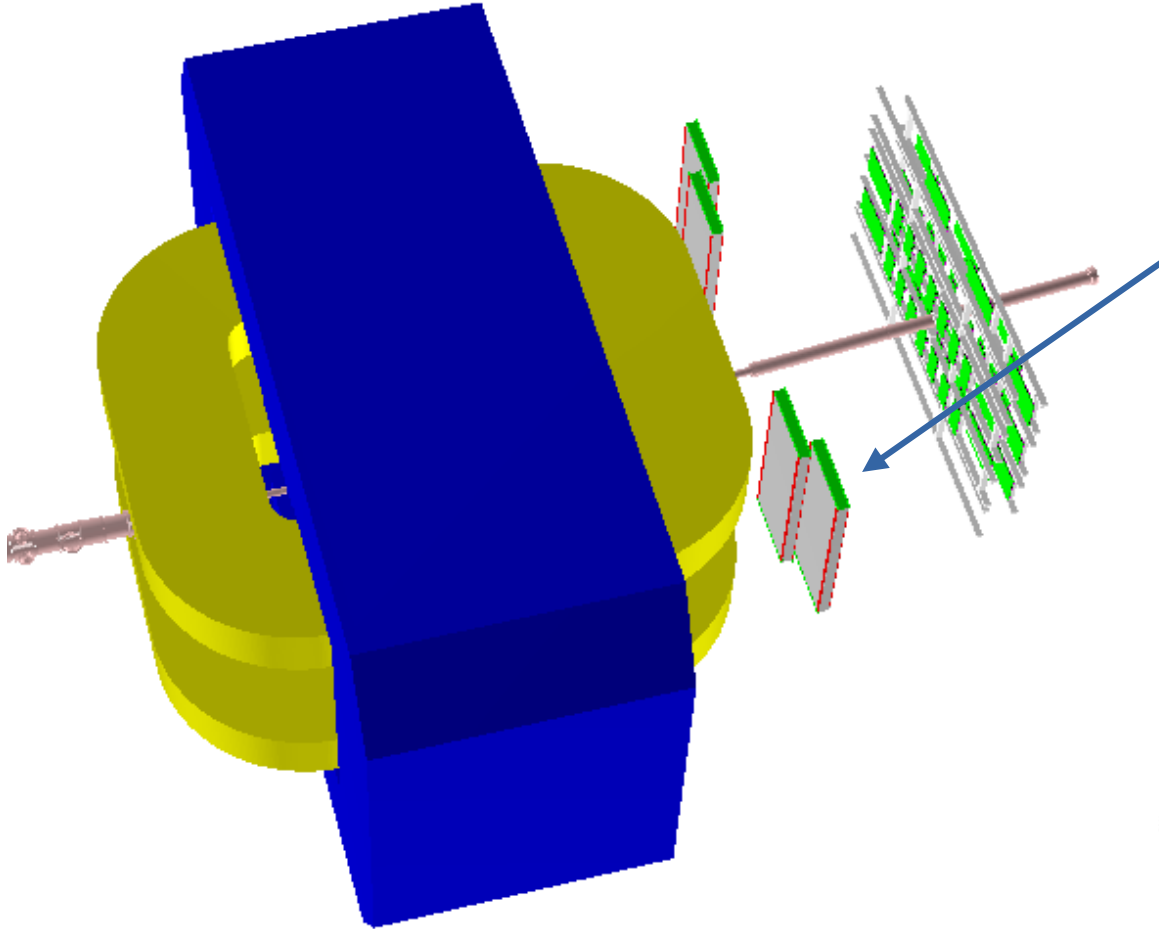

TOF400:

- 2 x 1.15x1.3 m<sup>2</sup>
- 20 detectors
- 1920 channels of FEE

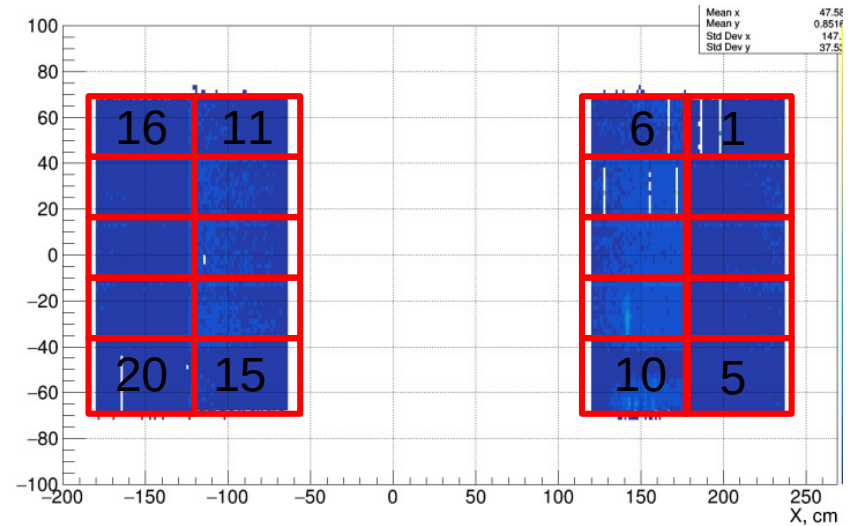

# Proposed Configuration

current configuration:

- 2 x 1.15x1.3 m<sup>2</sup>
- 20 detectors
- 1920 channels of FEE

extended configuration:

- 2 x 1.7x1.3 m<sup>2</sup>
- 30 detectors
- 2880 channels of FEE

Should be produced:

- MRPC — 10 pce
- FEE — 40 pce
- TDC — 14 pce
- New gas box

XY\_tr\_CutT7\_z430\_tr\_pi

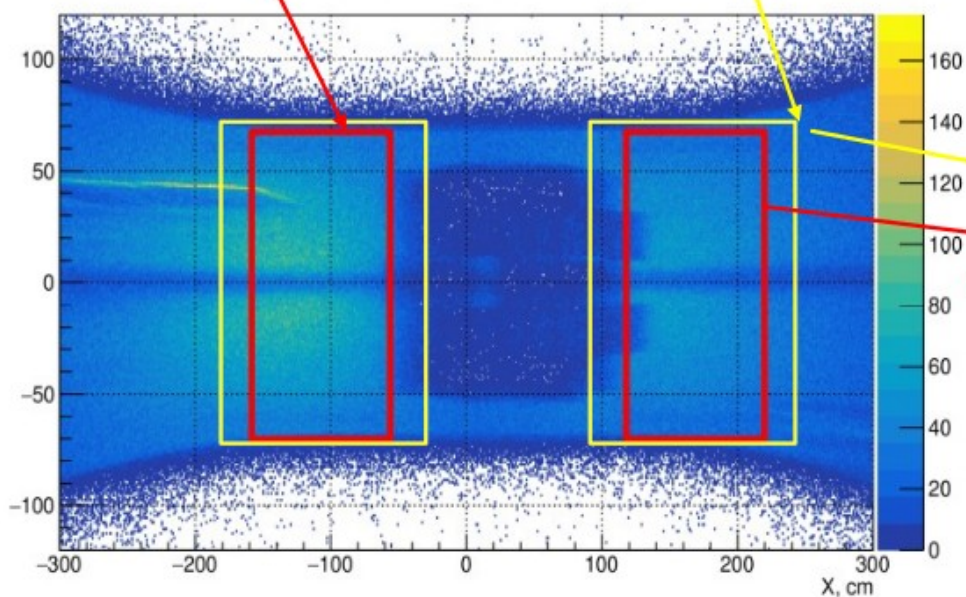

DCMQGSM Au+Au 3.8 AGeV.

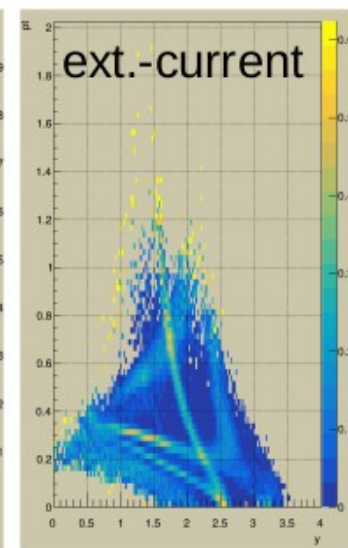
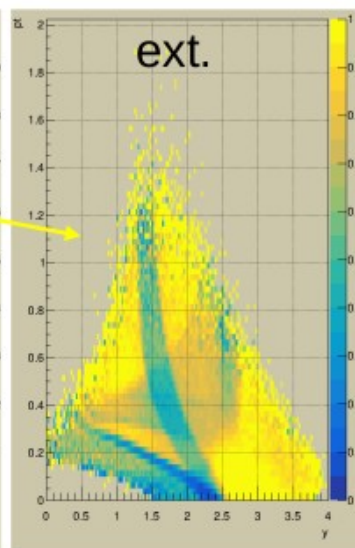
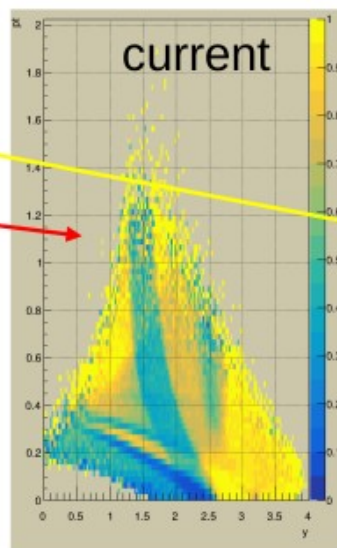

## Required materials

Material	Needed	In stock	Comment
Glass	180	180	<b>From NA61</b>
Honeycomb	20	18	<b>Ordered</b>
PCB	20	18	<b>Ordered</b>
Detectors	10	8	<b>In production</b>
Box	2	0	<b>In production</b>
FEE	40	0	<b>In production</b>
TDC	14	0	
Signal cable	40	40	<b>From MPD</b>
HV cable	20	0	<b>Ordered</b>

# Gas Box

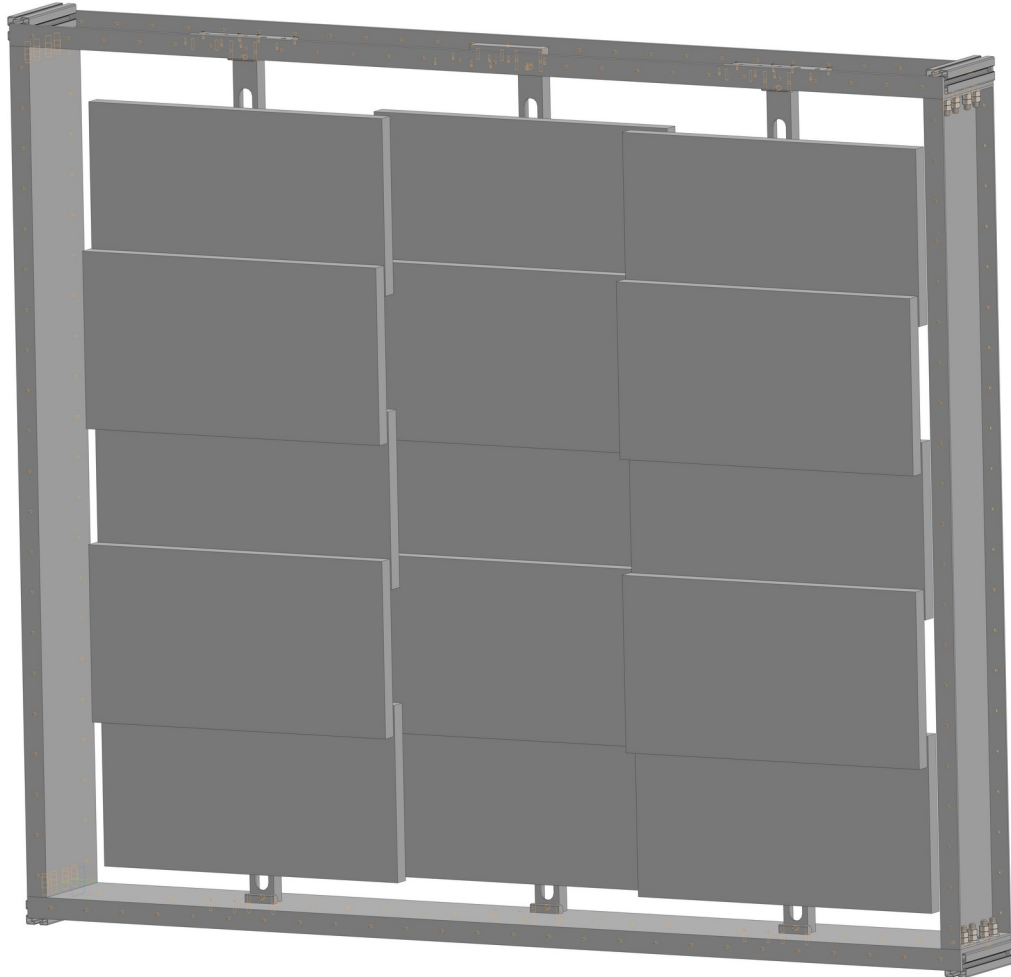

Box size -  $\sim 1,5 \times 1,8 \text{ m}^2$

Material — aluminium

Minimizing material budget near to beam axis

We are looking for a factory for production

- NPO «ATOM» - production is busy
- OOO «Pelkom» - Difficult situation at the factory

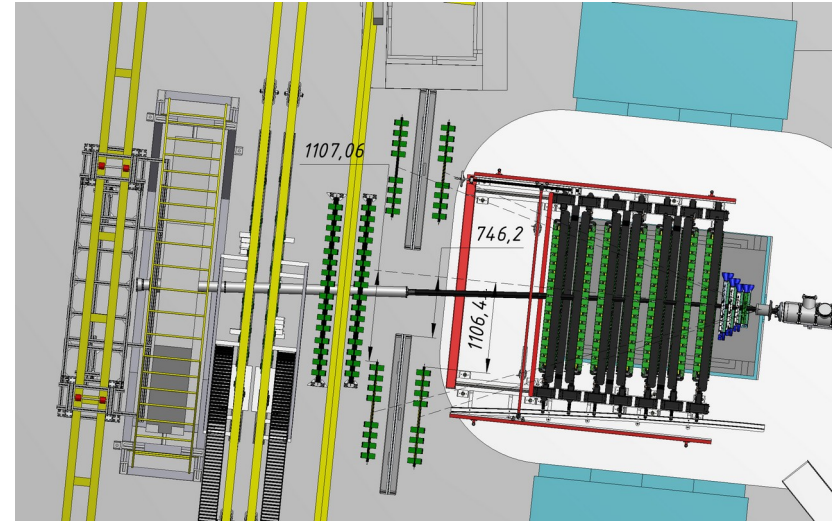

# Detector production

MRPC production will be finished in October



MRPC assembly process



MRPC's storage

# FEE and TDC



FEE



Signal cable

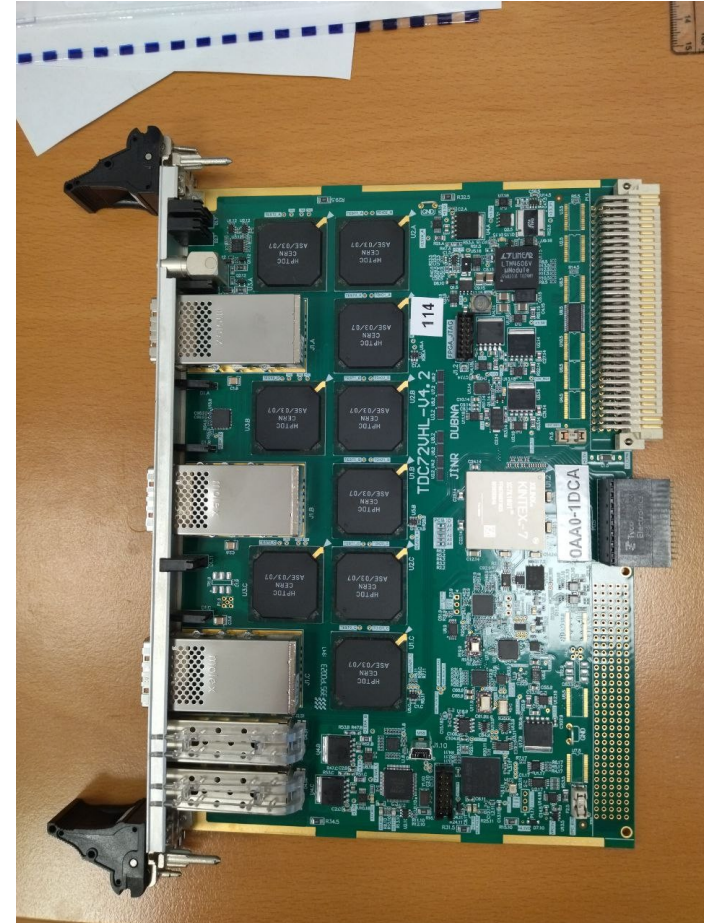

TDC

# FEE and TDC

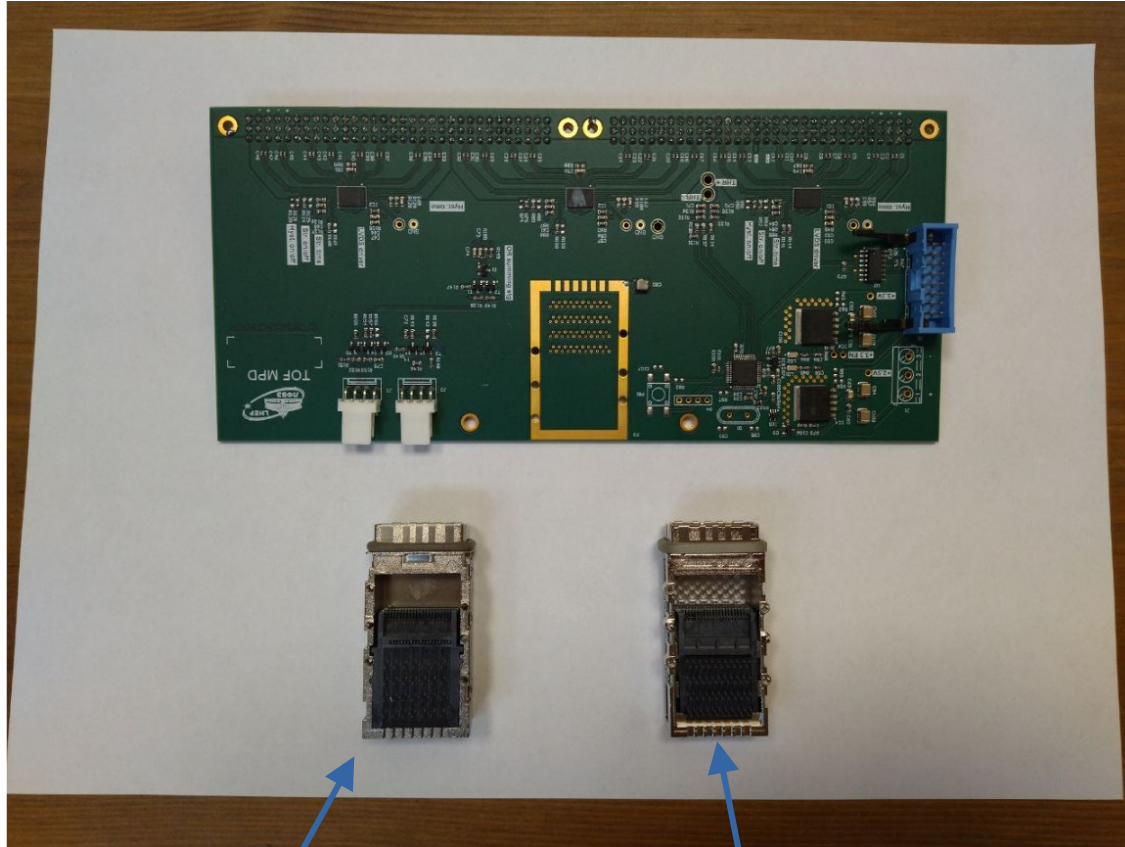

OLD CXP

NEW CXP

The FEE PCB already produced, but old CXP connector are not available anymore.

The existing stock of connectors will be used for the TDC production.

New FEE board for new CXP connector is under design.

NINO chips will be transferred to new board.

FEE production will be finished in november.



# Conclusion

	09.23	10.23	11.23	12.23	01.24	02.24	03.24
Detector production							
Box production		?	?	?	?	?	?
FEE							
TDC							
Instalation							
Operation							

Next BM@N run will be on «old» configuration of TOF400