

Научная сессия секции ядерной физики ОФН РАН

г. Дубна, ОИЯИ



# Digital signal processing models for the ECal of the MPD experiment at NICA

---

Rivu Adhikary <sup>a,\*</sup>)

V. Baryshnikov <sup>a)</sup> and I. Tyapkin <sup>a)</sup> *on behalf of MPD collaboration*

<sup>a</sup> Joint Institute for Nuclear Research, 141980, Dubna, Russia

\* email : [adhikary@jinr.ru](mailto:adhikary@jinr.ru)

1 April, 2024

# OUTLINE

---

- Introduction
- ECal in MPD
- Test Setup
- Fitting models
- Coefficient of determination approach (R squared criteria)
- Data Analysis
- Conclusion

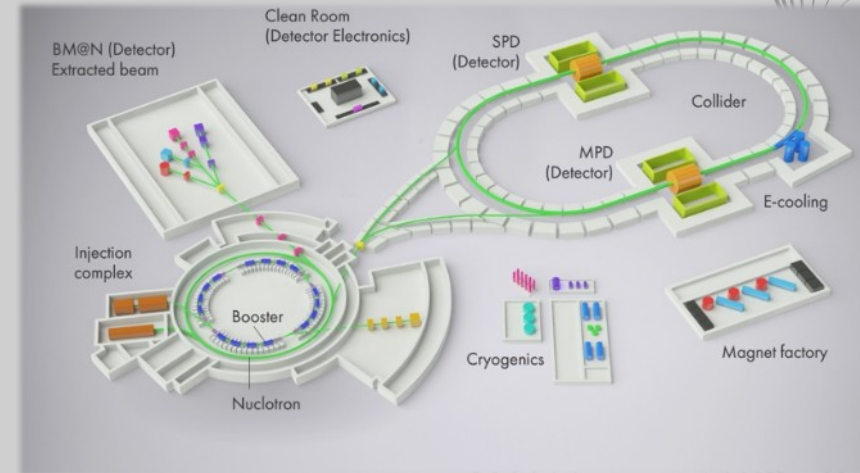

# INTRODUCTION

- ♦ Multi-Purpose Detector (MPD) at NICA aims to provide event wise measurements for studying high-density effects in baryonic matter.
- ♦ The Shashlyk type electro-magnetic calorimeter (ECal) in MPD enables precise spatial and energy measurements of photons and electrons :
  - In energy range 40 MeV to 2-3 GeV.
  - In central pseudo-rapidity zone of  $|\eta| < 1.2$ .
- ♦ ECal is divided into 25 sectors or 50 half-sectors, each with 48 modules.

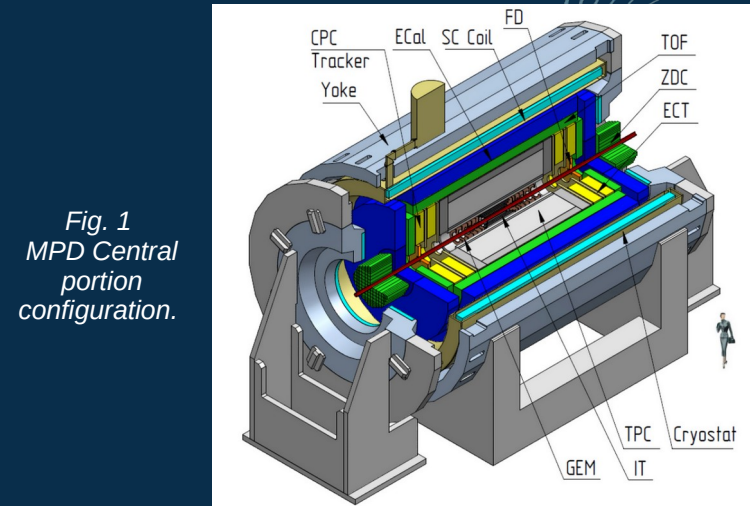

Fig. 1  
MPD Central  
portion  
configuration.

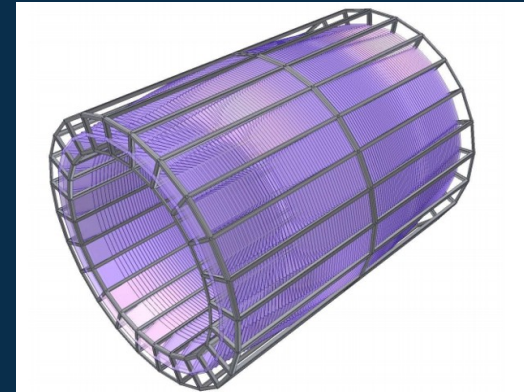

Fig. 2  
ECal Structure

# Electro-magnetic Calorimeter in MPD

- ECal modules are made up of 16 towers (channels) that are bonded together.
- Each tower contains 210 polystyrene scintillator layers and 210 lead plates with 16 Wave Length Shifting (WLS) fibers for collecting the scintillation light.
- Four modules are combined to form one ADC64ECAL board.
- Each ADC board comprises 64 channels.
- In a single 3 meters long half sector, there are 12 plates, resulting in 48 modules and a total of 768 channels.



*Fig. 3  
An ECal module*



*Fig. 4 One ADC64ECAL Board*

# TEST SETUP - 1

---

Special installation has a support structure that is used to mount Data Acquisition (DAQ) System and detector equipments.

LEDs and cosmic radiation were used to test the half-sectors and other components of the ECal.



*Fig. 5 Special setup for testing ECal half-sectors at JINR*

# TEST SETUP – 2

Three Modules underwent testing at the 1.2 GeV electron synchrotron "Pakhra" at LPI RAS in Troitsk.

Using a quasi-monochromatic beam of "secondary" electrons at different energies: 30, 70, 100, 150, 200, 250, and 280 MeV.

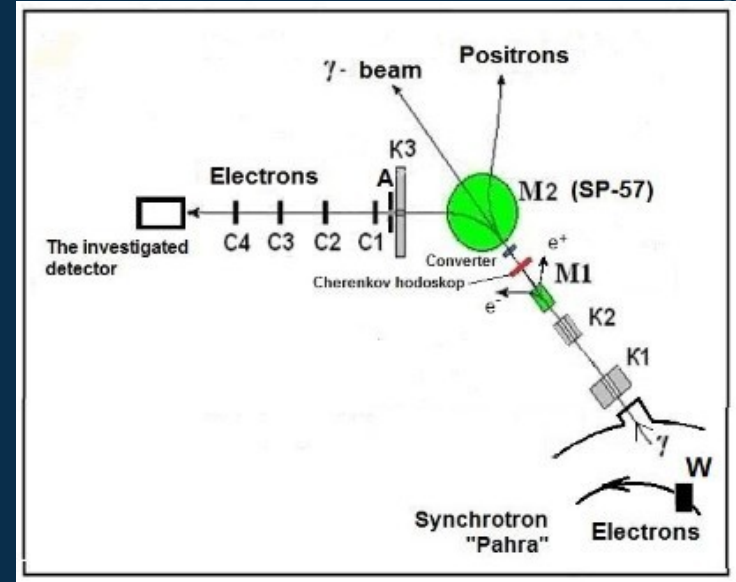

Fig. 6 Calibration Set up of "Pakhra" Synchrotron at LPI RAS

# Fitting Model – 1

## Novosibirsk Function :

- This function is particularly valuable for describing asymmetric peak shapes.
- The functional form :

$$f(x; n, \mu, \sigma, \tau) = n \times \exp \left[ -\frac{1}{2} \left( \frac{\log(\xi)}{w} \right)^2 - \frac{w^2}{2} \right]$$
$$\xi = 1 - \frac{(x - \mu) \times \tau}{\sigma} \quad w = \frac{\sinh \tau \sqrt{\log 4}}{\sqrt{\log 4}}$$

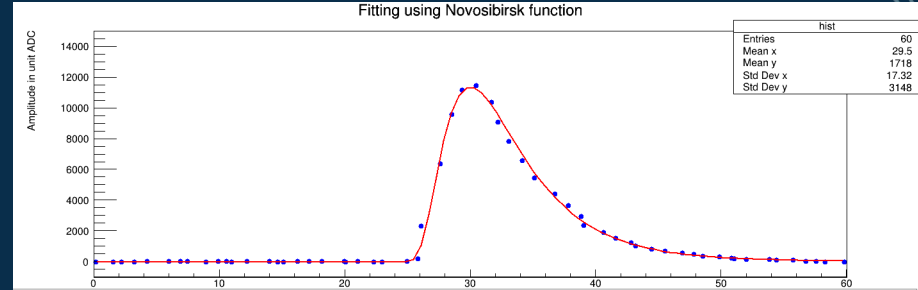

Fig. 6 Fitted Original signal using Novosibirsk function

Here  $\mu$  the peak position ,  $\tau$  controls the tail asymmetry and  $\sigma$  is the width parameter.

The fit reduces to Gaussian with  $n$ ,  $\mu$ , and  $\sigma$  if  $\tau = 0$  .

# Fitting Model – 2

## Sum of Exponentials :

- Sum of exponentials using Prony's method is a technique for approximating signals as a sum of exponentially decaying components.
- If noise is present in that signal, Prony's approach is not much effective , so instead the fast Estimation of Signal Parameters via Rotational Invariance Techniques (fast ESPRIT) method has been employed, as in the following equation :

$$f_k = \sum_{j=1}^M c_j e^{-a_j(t_0 + hk)} = \sum_{j=1}^M w_j z_j^k$$

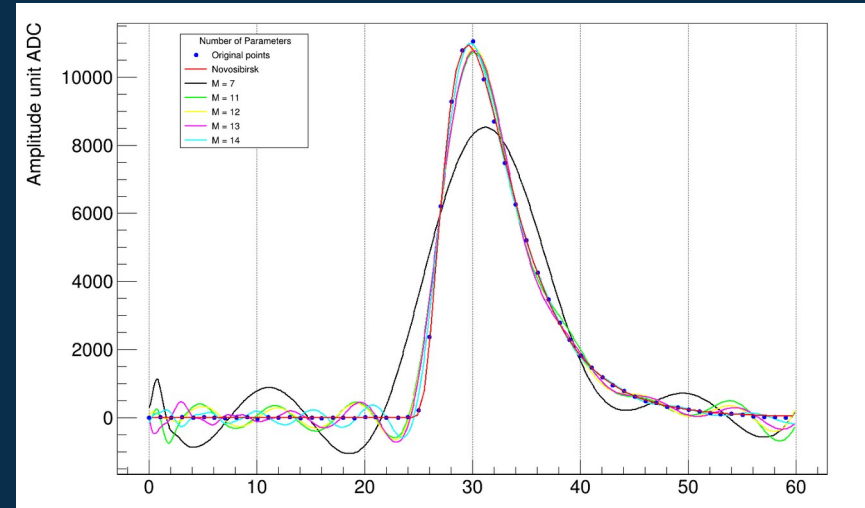

Fig. 7 Processing a waveform with Novosibirsk and SoE model

For thorough mathematical explanation of the fast ESPRIT method : <https://doi.org/10.1016/j.cpc.2018.04.015>



# Coefficient of determination approach (R squared criteria)

The coefficient of determination ( $R^2_{adj}$ ) is determined by the following expression:

$$R^2_{adj} = 1 - \frac{RSS/(N - \lambda)}{TSS/(N - 1)} = 1 - (1 - R^2) \frac{N - 1}{N - \lambda},$$

Where :

- RSS (Residual Sum of Squares) is the sum of squares of regression residuals,
- TSS (Total Sum of Squares) - total variance,
- $x[n]$  is the actual value of the explained variable,
- $\hat{x}[n]$  is the calculated value from the function,
- $\bar{x}$  is the sample mean,
- $N$  is the number of measurements,
- $\lambda$  is the number of parameters.

$$RSS = \sum_{n=1}^N (x[n] - \hat{x}[n])^2, \quad TSS = \sum_{n=1}^N (x[n] - \bar{x})^2.$$

*In the following slides we use  $(1 - R^2_{adj})$  distributions for a better understanding of the fitting models.*

*The fitting is better the closer  $(1 - R^2_{adj})$  is to zero.*

# Data Analysis using a small sample event with cosmic ray signals

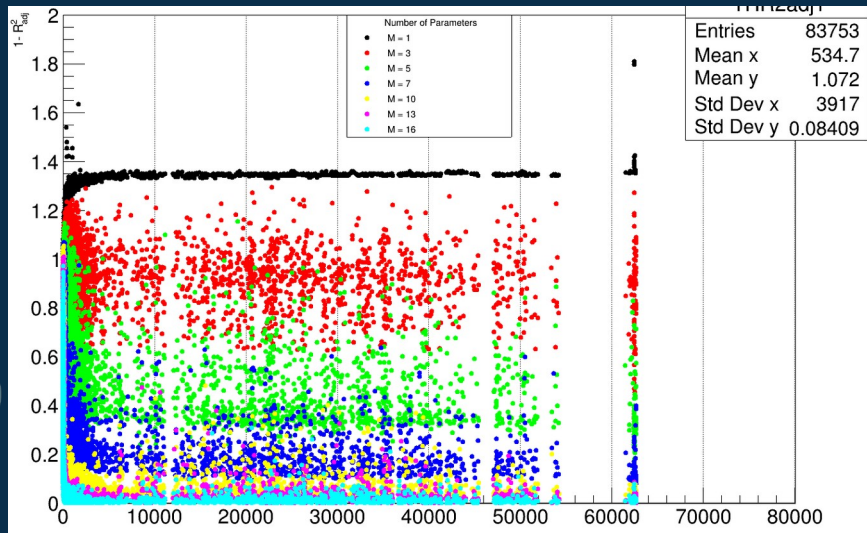

Fig. 8 ( $1 - R^2_{adj}$ ) vs Maximum Amplitude using Sum of Exponent model with different parameters

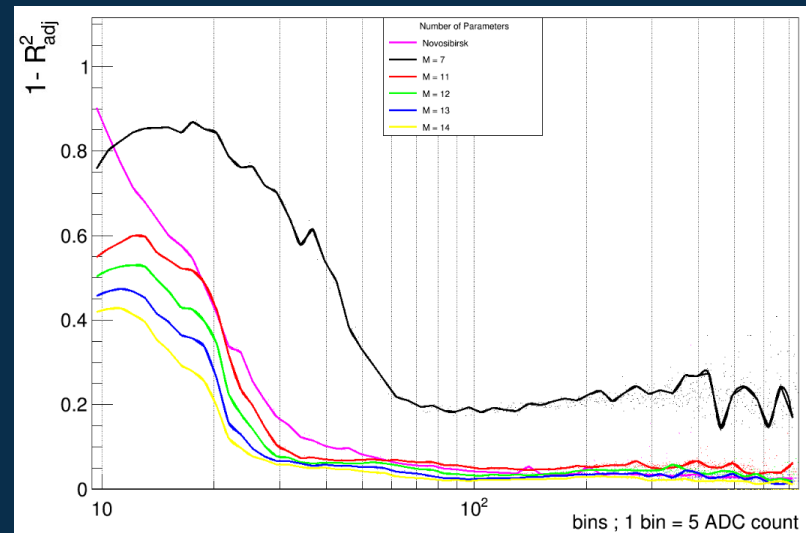

Fig. 9 Comparison of two models using Mean of ( $1 - R^2_{adj}$ ) vs bins of Maximum Amplitude

# Data Analysis using quasi-monochromatic beam of secondary electrons at 250 MeV

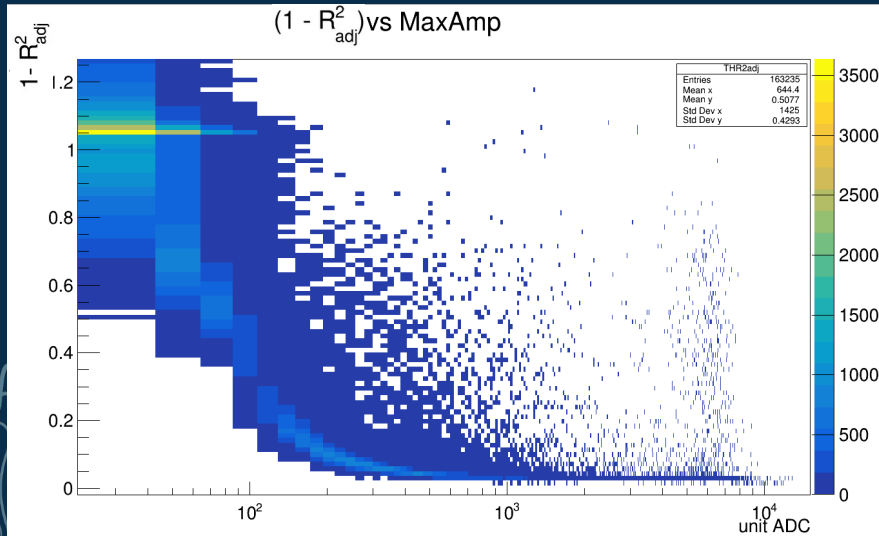

Fig. 10  $(1 - R^2_{adj})$  vs log of Maximum Amplitude using Novosibirsk function

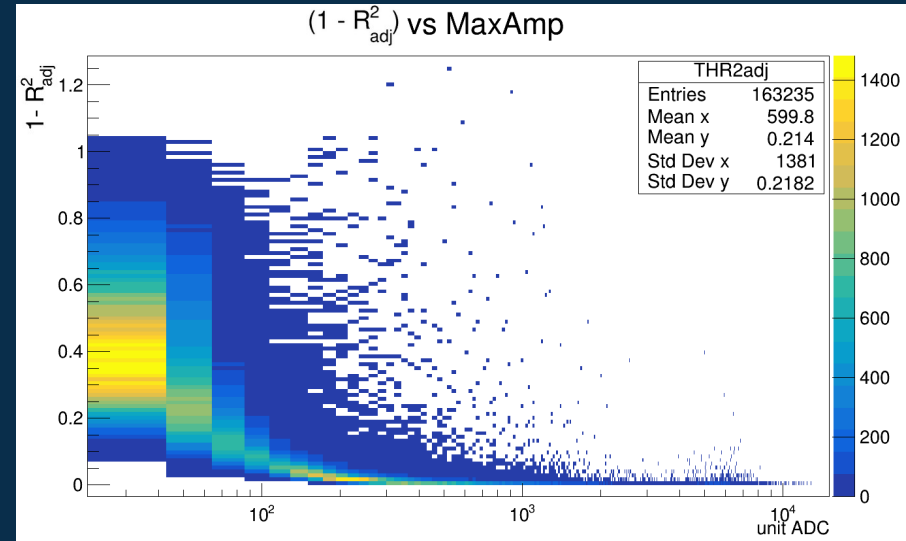

Fig. 11  $(1 - R^2_{adj})$  vs log of Maximum Amplitude using Sum of Exponent module with 14 parameters

# Data Analysis – Resolution vs Energy

Figure 12 displays the resolution and uncertainties of a module based on observed energies in MeV.

$$\text{Resolution} = (\text{Sigma}/\text{Mean}) \times 100\%$$

The Novosibirsk function provides better resolution at lower energies compared to the original and sum of exponent models.

Resolution improves with higher energy levels, showing similar trends in both fitting models.

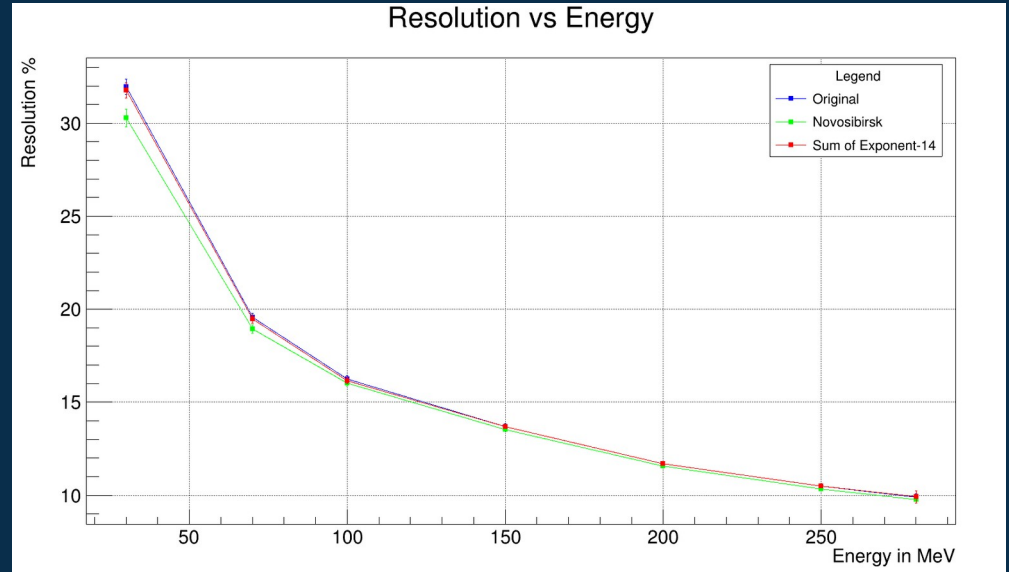

Fig. 12 Resolution vs Energy of module 260

# CONCLUSION

---

- Choosing the best model is crucial for accurate data representation.
- The fast ESPIRIT sum of exponents model offers a quick and accurate fit to original values.
- Novosibirsk function is resilient against over-fitting and suitable for noisy datasets.
- Coefficient of determination is less effective for Novosibirsk but useful for peak shapes.
- Resolution at higher energies is comparable between the models.
- Fitting models don't significantly improve energy resolution at MPD experiment energies.
- Future studies will explore applications of models in different tasks and address noise-related challenges.



1-



***Thank you for your Attention***

**Questions Please !**

# Back up figures

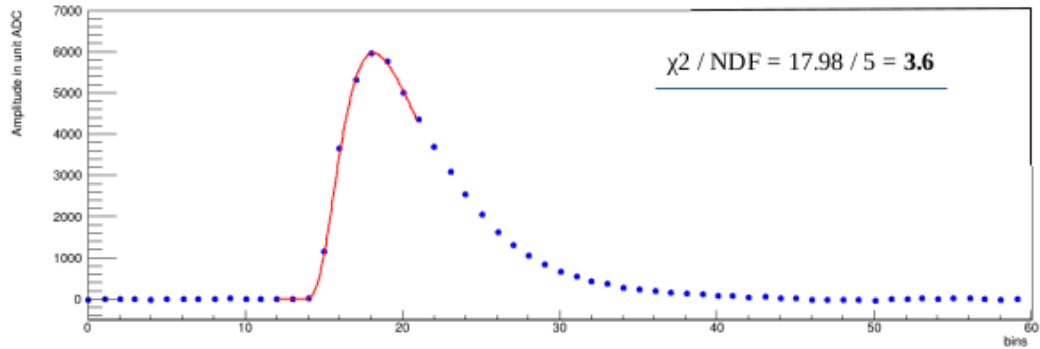

Fig. 4. Fitted Original signal using Novosibirsk function

$$\chi^2 = \sum_{i=1}^n \frac{(O_i - E_i)^2}{E_i}$$

Value for  $R^2_{\text{adj}}$

Coefficient Interval	Value	Relationship Category
0.000 - 0.199		Very low
0.200 - 0.399		Low
0.400 - 0.599		Currently
0.600 - 0.799		Strong
0.800 - 1.000		Very strong

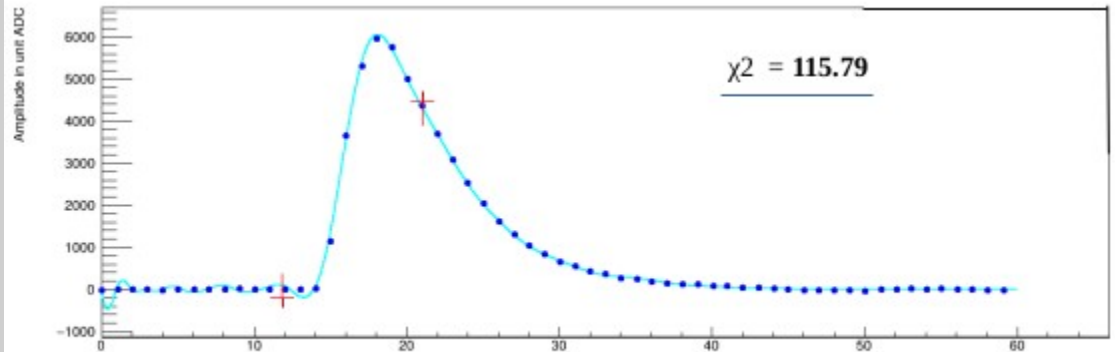

Fig. 5. Fitted Original signal using Sum of Exponent with 14 terms