



# Development of new High Granualr Neutron Detector for the BM@N experiment

A. Makhnev  
Institute for Nuclear Research of RAS  
AYSS-2024, 10.24

# EoS and neutron flows measurements at the BM@N

- EoS describes the relation between density, pressure, energy, temperature and the **isospin asymmetry**
- The study of  $E_{\text{sym}}$  density dependence is very important for the understanding of astrophysical phenomena like supernovae and neutron stars.
- The radius of a neutron star depends on the symmetry energy behaviour at high nuclear matter density.

$$E_A(\rho, \delta) = E_A(\rho, 0) + E_{\text{sym}}(\rho)\delta^2 + O(\delta^4)$$

Symmetric matterSymmetry Energy $\delta = (\rho_n - \rho_p)/\rho = (N-Z)/A$

- Collective flows of charged particles are a **sensitive probe** of  $E_{\text{sym}}$  at high densities at intermediate energies where reaction dynamics is largely determined by the nuclear mean field.
- Measurements of ratio of neutrons/protons flows at nuclear matter density range  $(2-4)\rho_0$  can be performed at nearest perspectives only at the BM@N.
- **Neutron detector to measure neutrons flows is needed.**

# Detector arrangement

- Detector for high-energy neutron flow measurement
- ToF method with T0 as the “start” signal source
- 7m measurement distance
- Detector is split into 2 “blocks” for improved acceptance

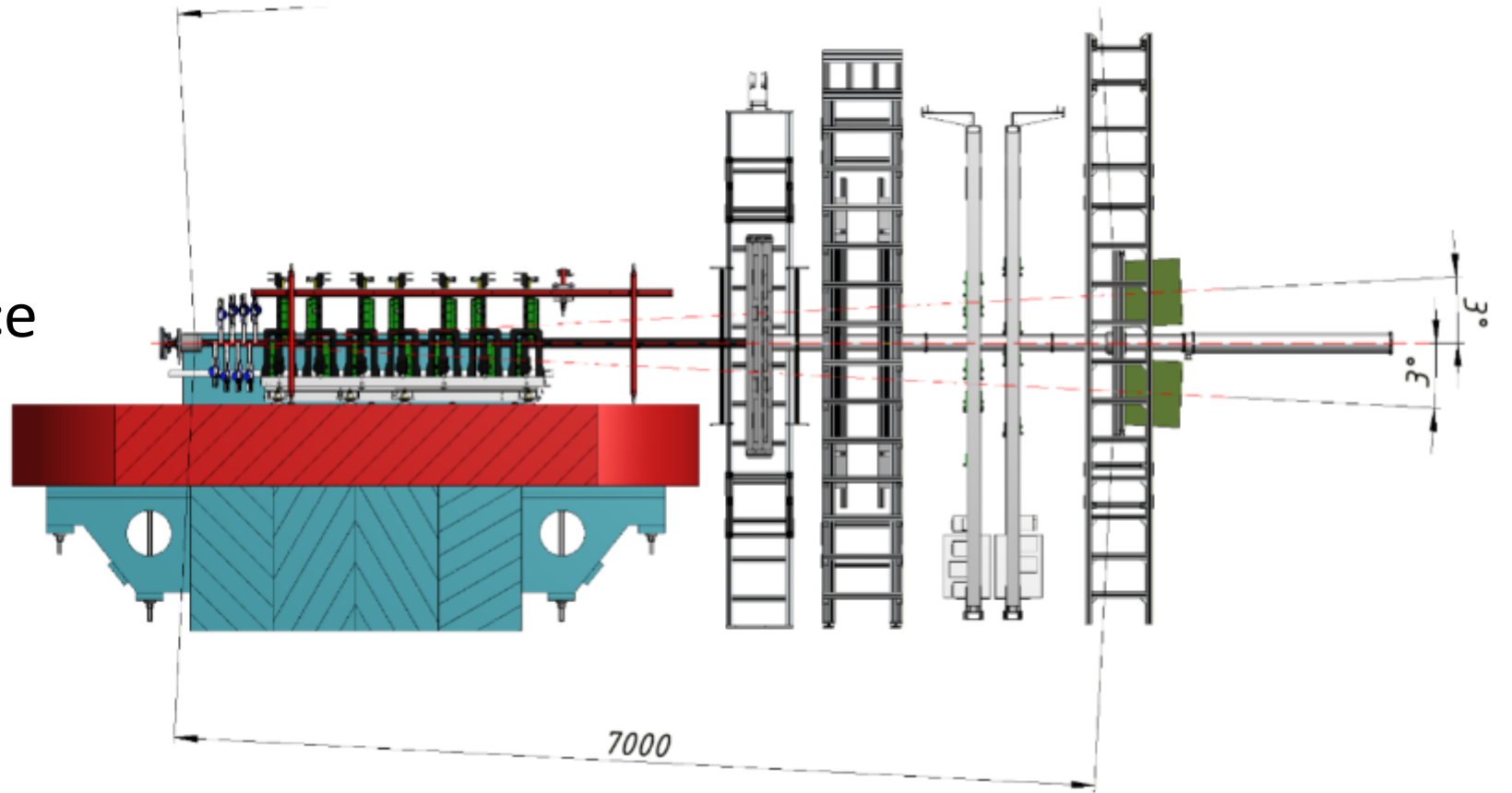

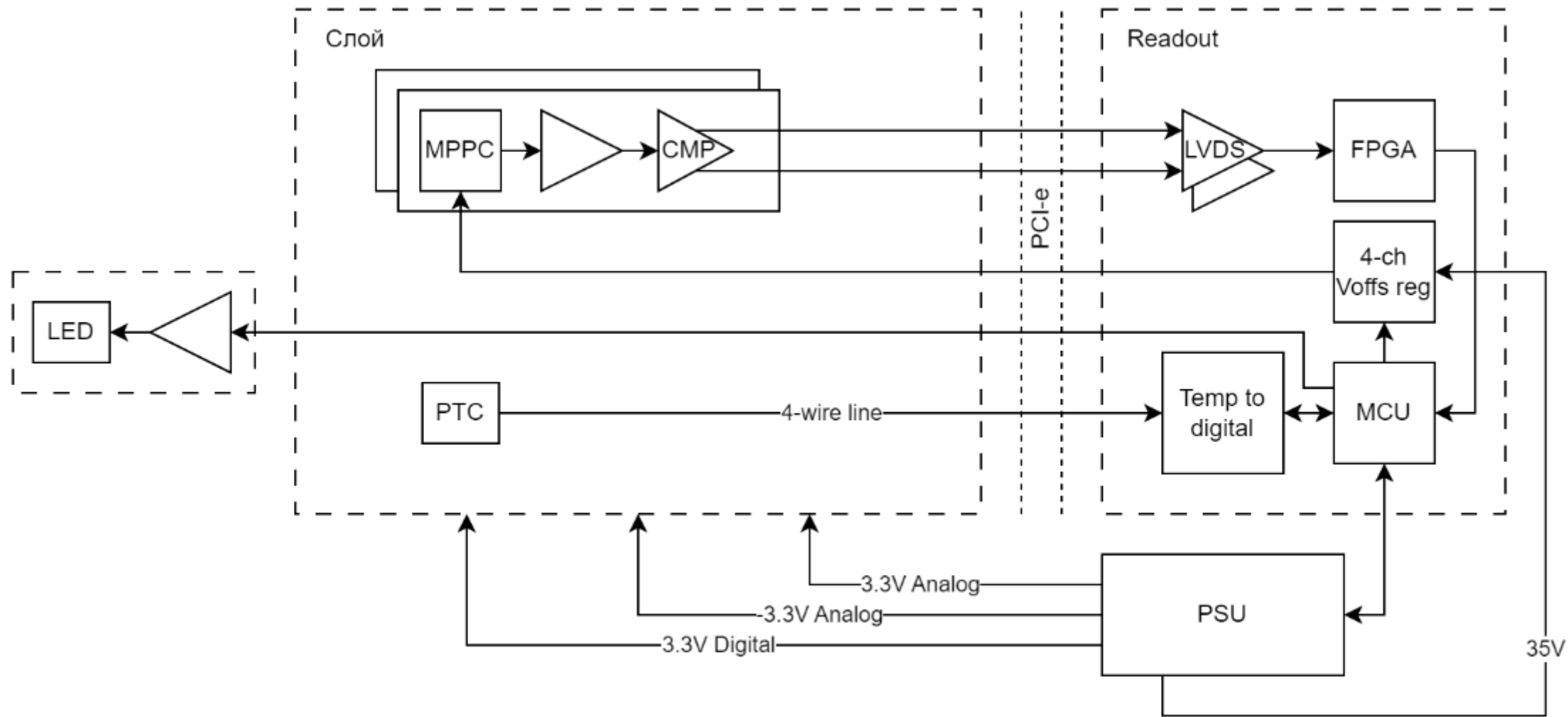

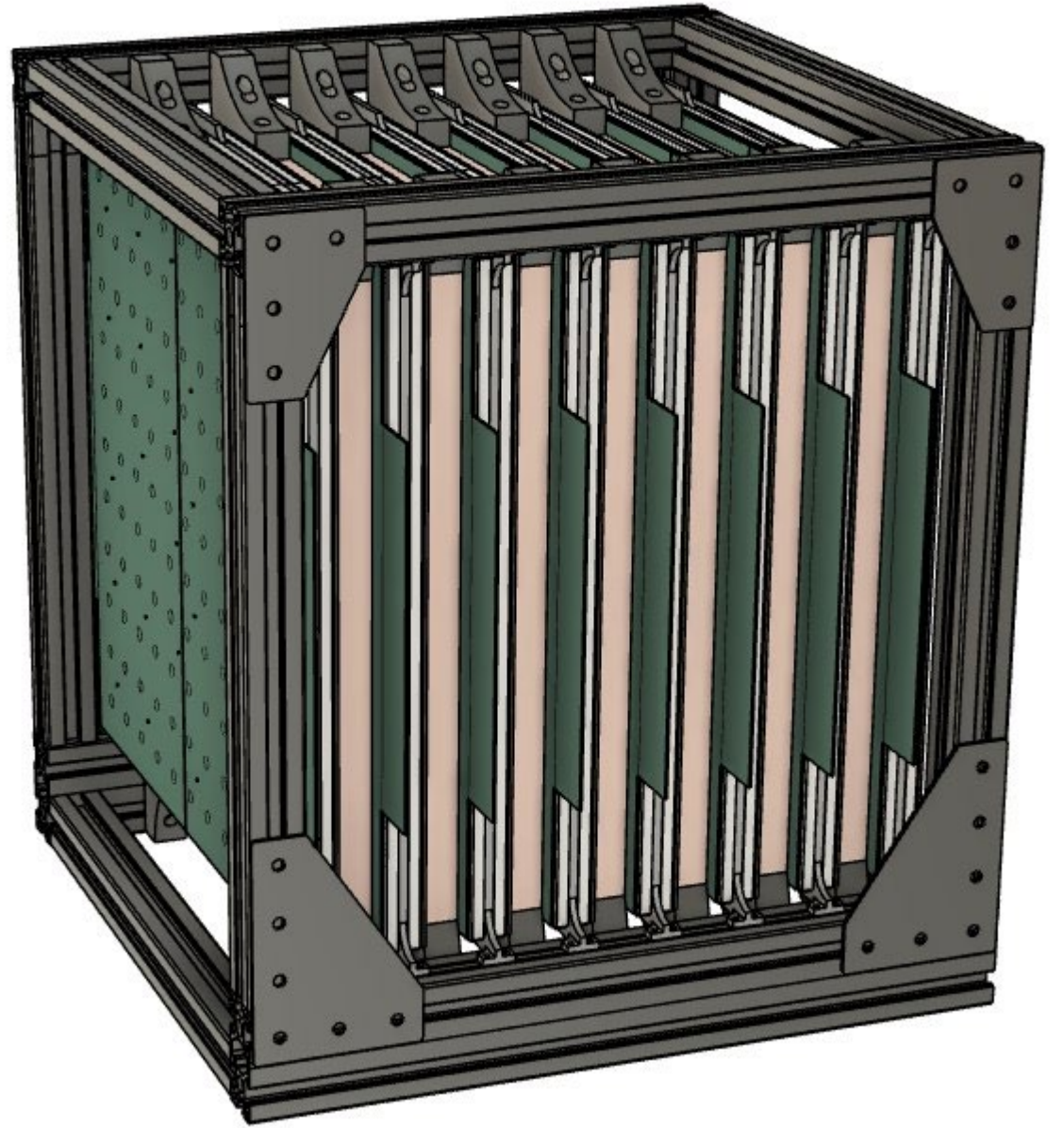
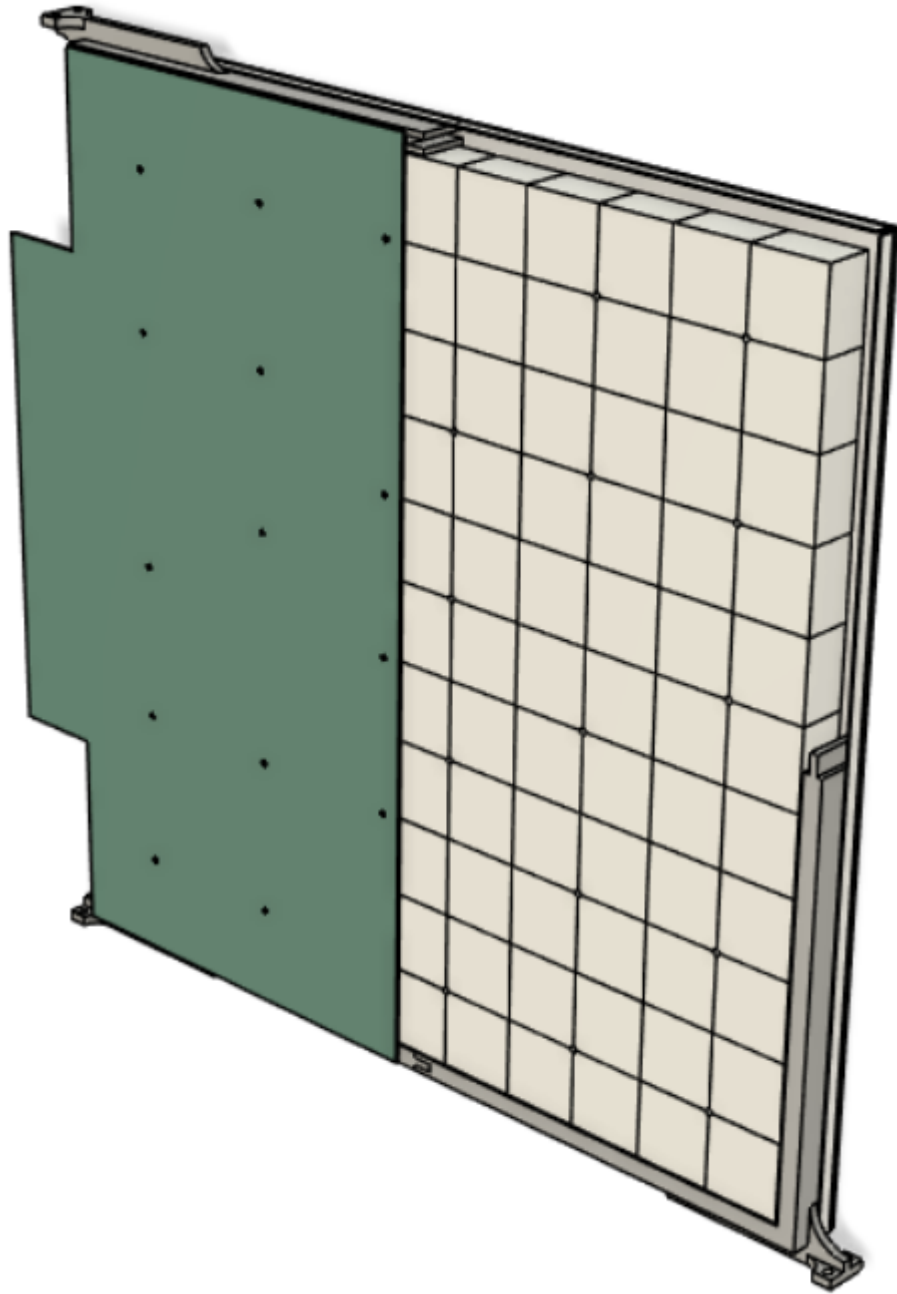

# Scintillation module status

- Single-channel prototype
- Multi-channel PCB design
- Multi-channel mechanical design
- Multi-channel mechanical and PCB prototypes
- **Half-layer prototype**
- Full-scale prototype
- Full-scale completed layer

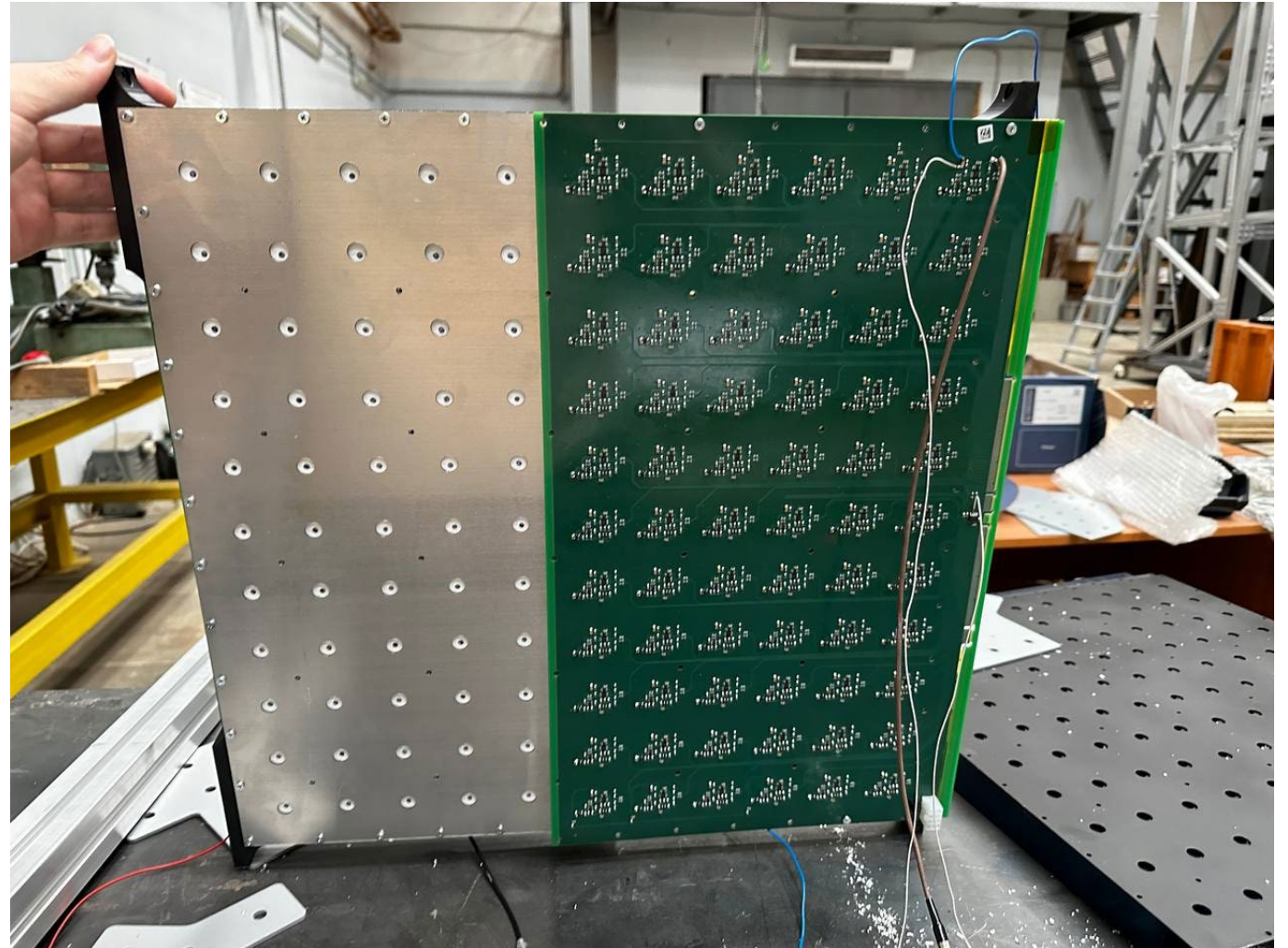

# MPPC board

- Single-channel prototype
- Multi-channel PCB design
- **Full-scale prototype**
  - Single-channel test
  - Crosstalk test
  - Readout integration
- Full-scale completed PCB

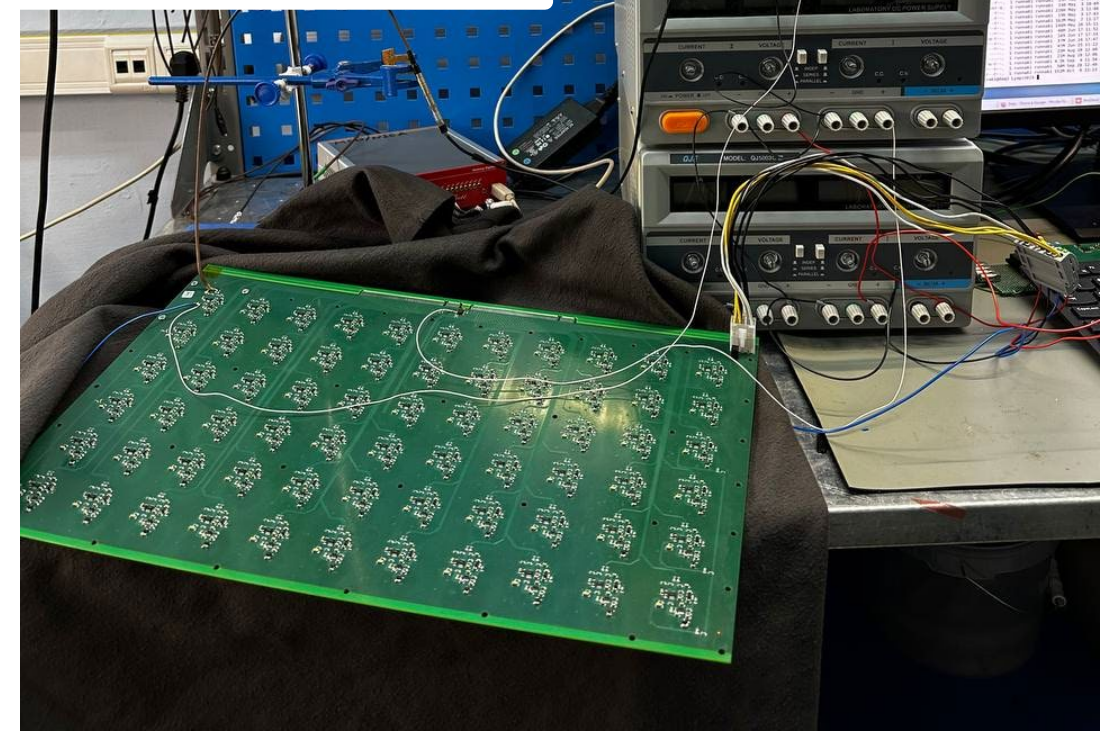
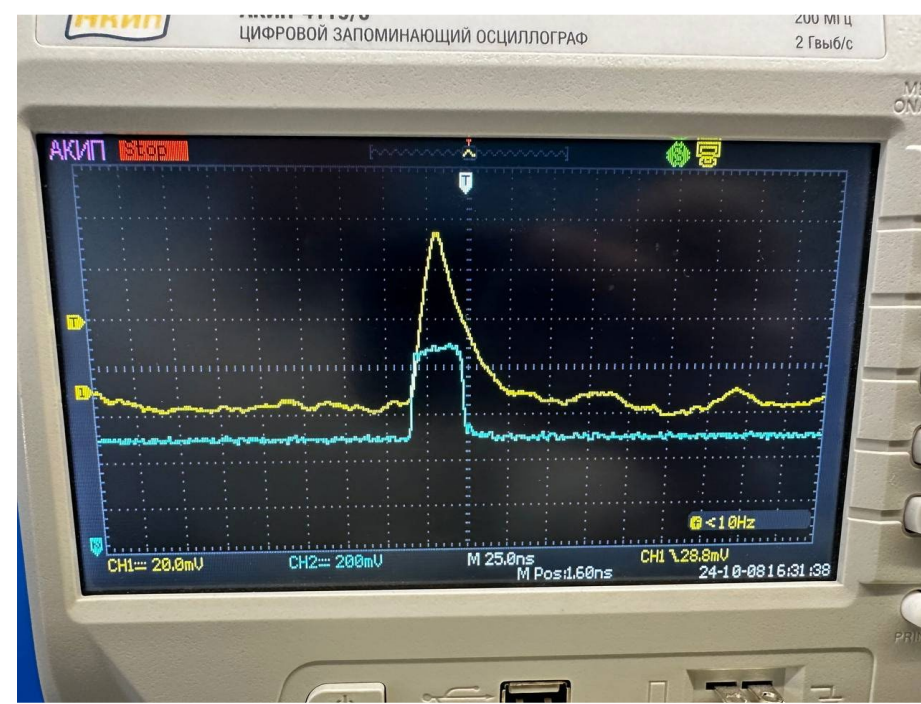

# LED board

- Single-channel prototype
- Multi-channel PCB design
- **Full-scale prototype**
  - Single-channel test
  - Crosstalk test
  - Current loop test
  - Slow control integration
- Full-scale completed PCB

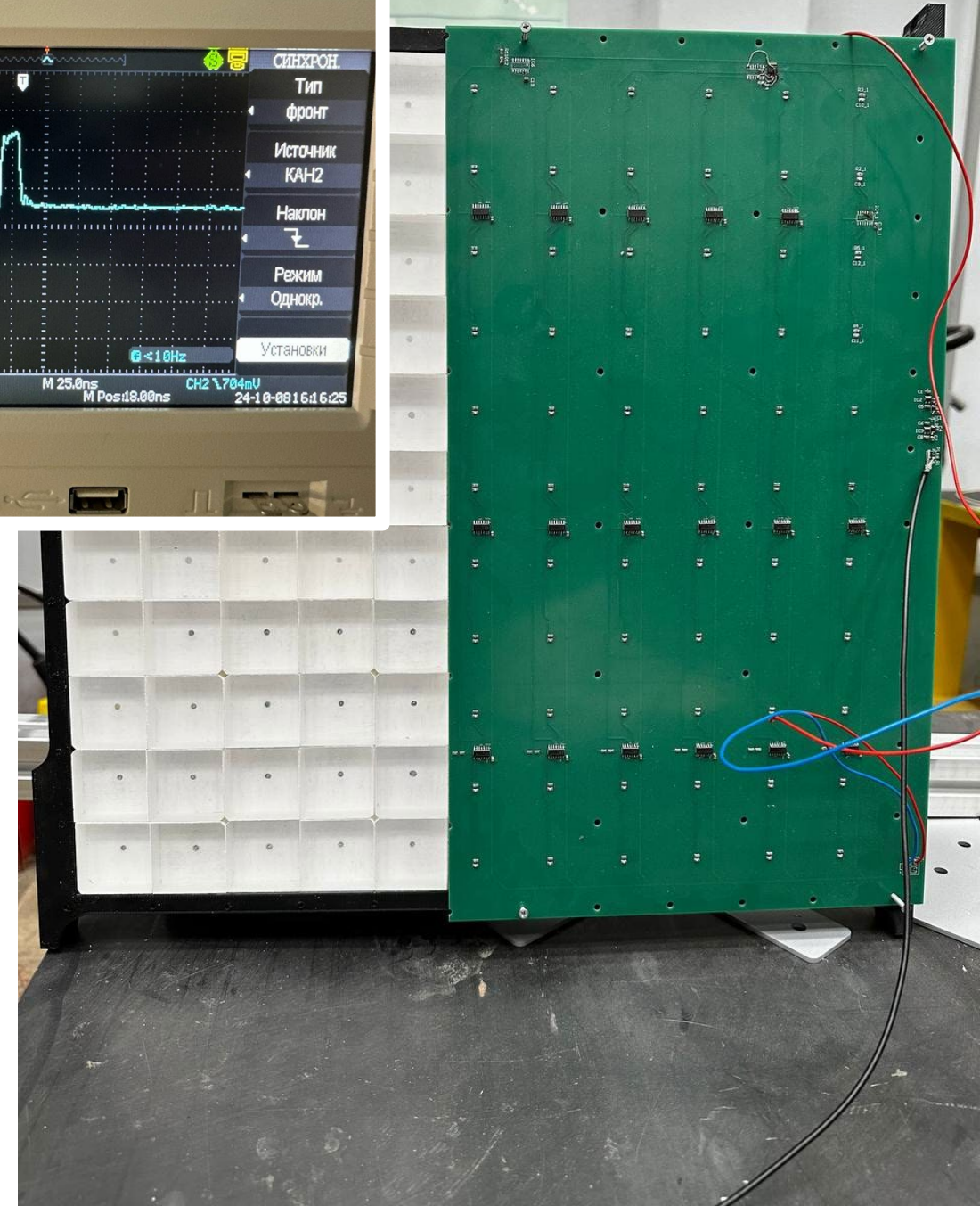
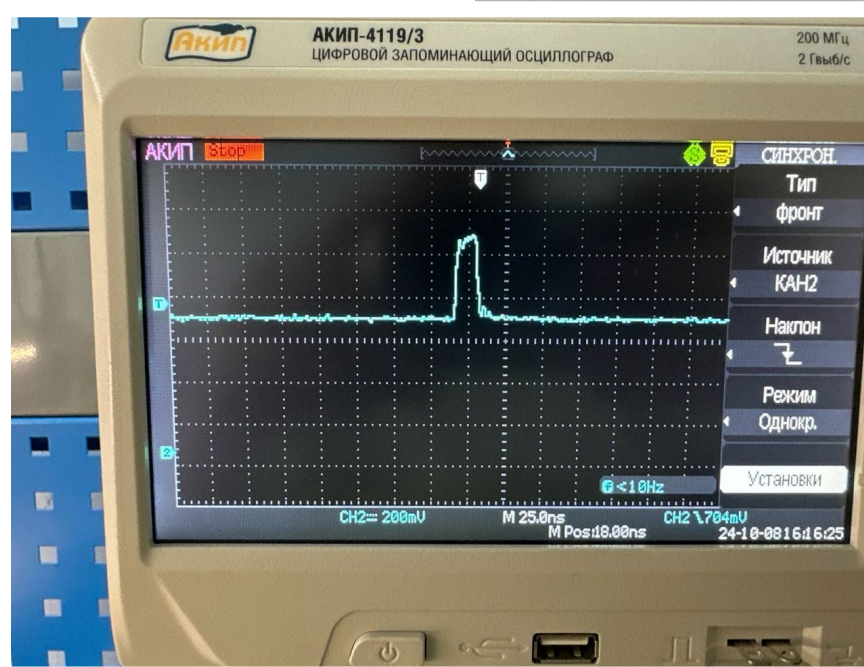



# Mechanical construction - module

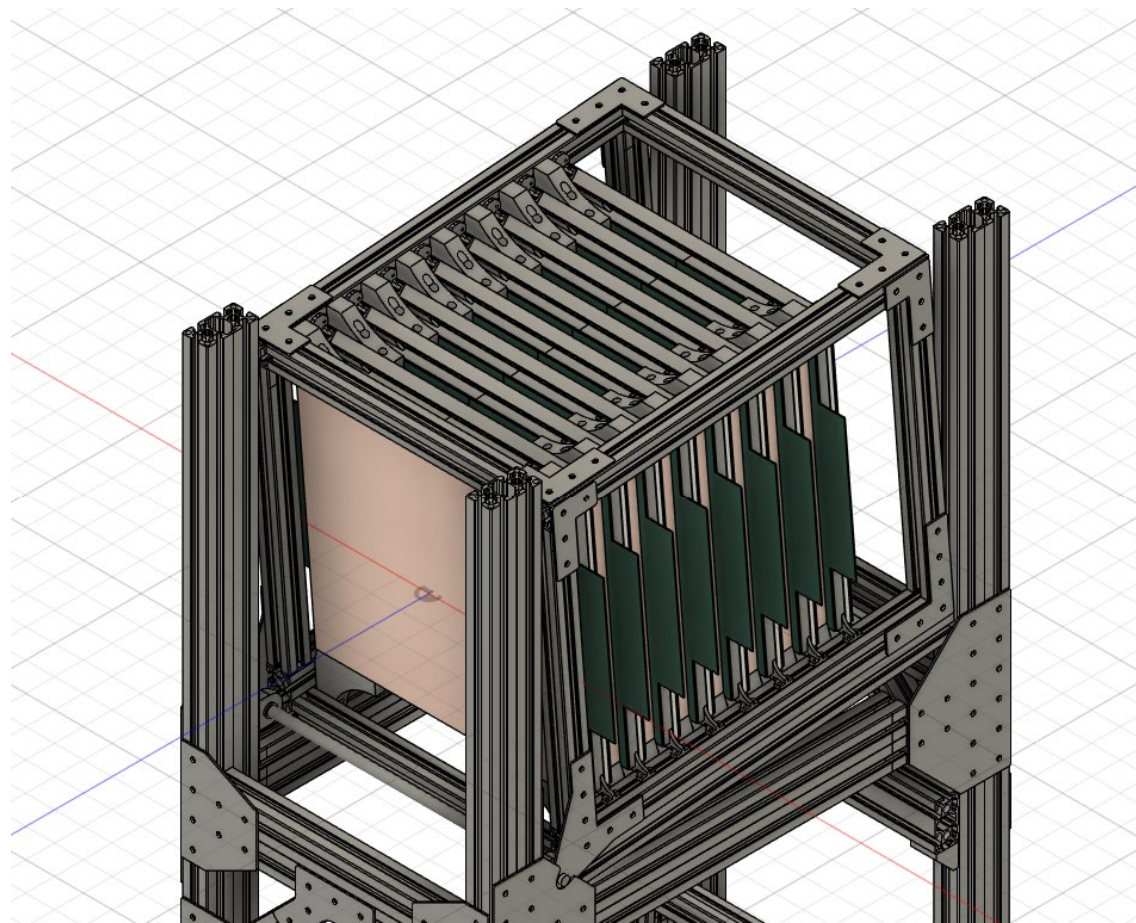

# Mechanical construction - support

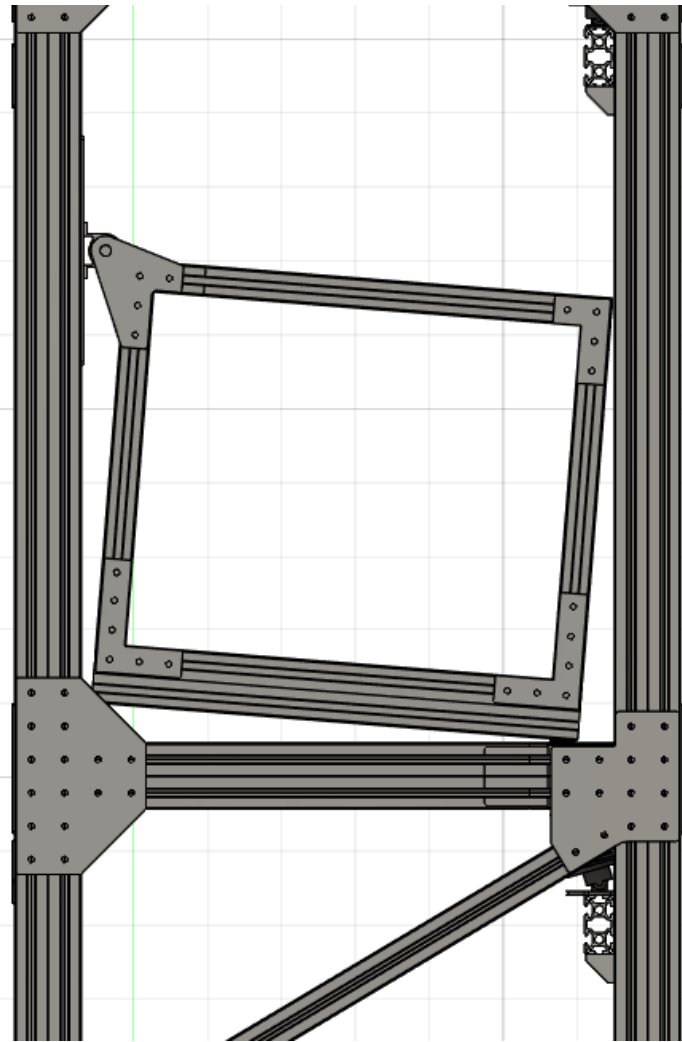
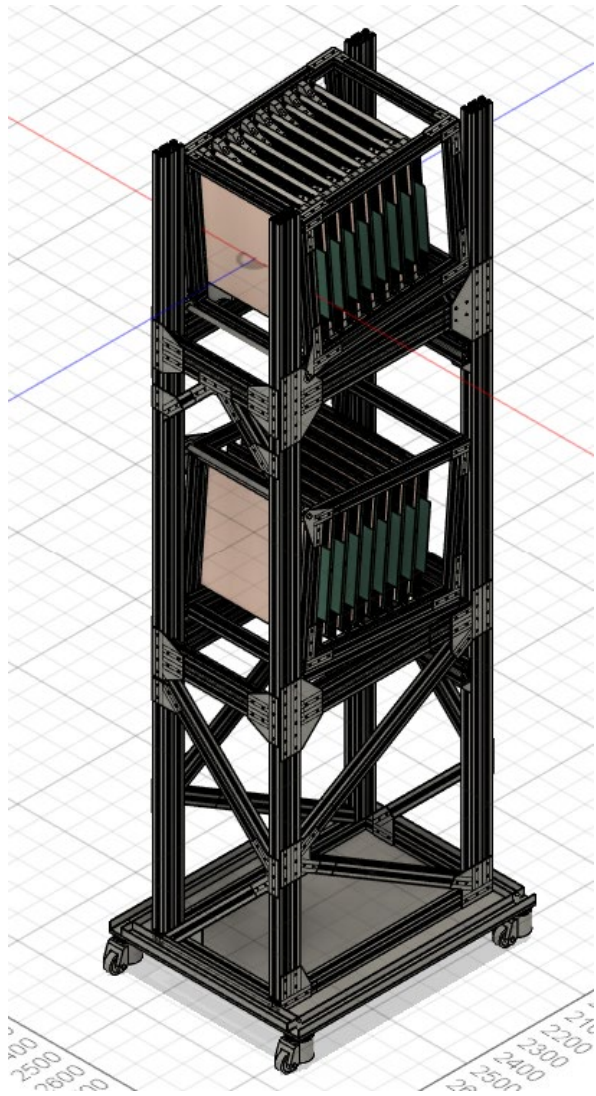

# TODO items

- Mechanical construction completion
- Full-scale tests of the readout board
- Full-scale tests of the LED board
- Readout integration
- Slow control integration
- Full-scale readout tests
- LED+Readout PCBs and modules mass production – by the end of 2024