

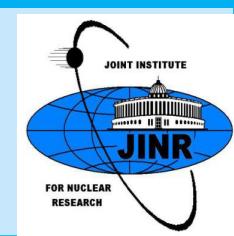

The **C**Oherent **M**uon to **E**lectron Transition (**COMET**) experiment



Experiment COMET at J-PARC

Status report and proposal for extension

Zviad Tsamalaidze

60th meeting of the PAC for Particle Physics

Dubna 17 June 2024

JINR COMET team

D.Aznabayev³, D.Baigarashev², D.Chokheli¹, T.L.Enik², I.L.Evtoukhovitch¹, P.G.Evtoukhovitch¹, D.Goderidze⁴, A.Issadykov³, V.A.Kalinnikov¹, E.S.Kaneva¹, X.Khubashvili¹, A.Khvedelidze⁴, G.A.Kozlov³, A.V.Pavlov¹, B.M.Sabirov¹, A.G.Samartsev¹, A.V.Simonenko¹, V.V.Tereschenko¹, Z.Tsamalaidze¹, N.Tsverava¹, I.I.Vasilyev¹, E.P.Velicheva¹, A.D.Volkov¹

¹Dzhelepov Laboratory of Nuclear Problems (DLNP)

²Veksler and Baldin Laboratory of High Energy Physics (VBLHEP)

³Bogoliubov Laboratory of Theoretical Physics (BLTP)

⁴Meshcheryakov Laboratory of Information Technologies (MLIT)

Charged Lepton Flavor Violation (CLFV)

The Periodic Table of Elementary Particles and Forces

Three Generations of Matter (Fermions)				
	I	II	III	
mass→	2.4 MeV	1.27 GeV	171.2 GeV	0
charge→	2/3	2/3	2/3	0
spin→	1/2	1/2	1/2	1
name→	u	c	t	Y
	up	charm	top	photon (electromagnetic)
	d	s	b	g
Quarks	down	strange	bottom (beauty)	gluon (strong force)
	<2.2 eV	<0.17 MeV	<15.5 MeV	91.2 GeV
	0	0	0	0
	1/2	1/2	1/2	1
	ν_e	ν_μ	ν_τ	Z
Leptons	electron neutrino	muon neutrino	tau neutrino	weak force
	0.511 MeV	105.7 MeV	1.777 GeV	80.4 GeV
	-1	-1	-1	+1
	1/2	1/2	1/2	1
	e	μ	τ	W
	electron	muon	tau	weak force
				115-185 GeV
				+1
				0
				H
				higgs boson

The Standard Model (SM) can explain most of the experimental results. However, there are still many questions to answer. All these motivate physicists to go Beyond the Standard Model (BSM) to explain this phenomenon.

We've quark mixing, Flavor Violation

We've neutrino mixing, Lepton Flavor Violation (LFV)
LFV = New physics in BSM

Charged Lepton mixing NOT observed. Why not charged leptons? Charged Lepton Flavor Violation (CLFV). Very small possibility in SM, BR ~ 0 (10⁻⁵⁴)

CLFV processes offer probes for new physics with discovery sensitivity. The most sensitive probes of CLFV utilize high-intensity muon beams.

Muon-to-Electron conversion mechanism

Stopped μ^- in matter (Al) generate "muonic atom" (lifetime in Al ~864 ns)

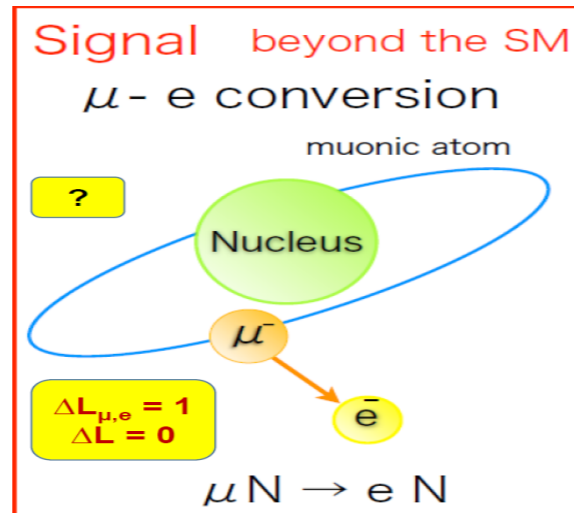
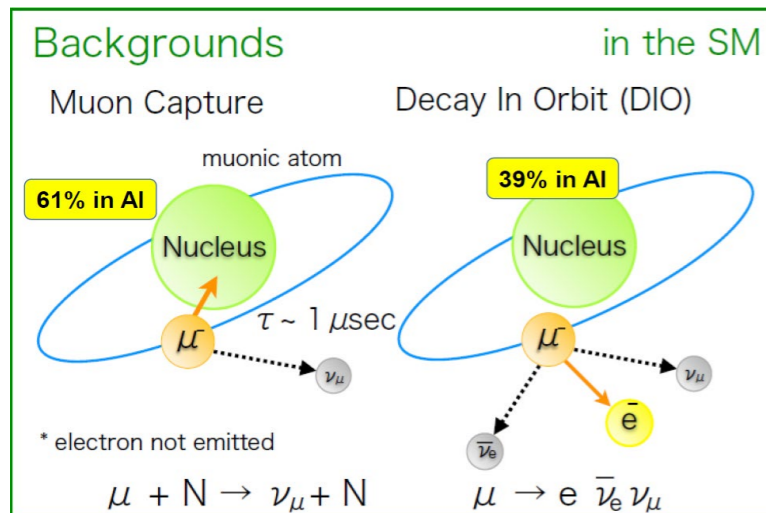

New Physics Process

Neutrino-less nuclear capture of a muon

(= $\mu - e$ conversion)

$$\mu^- + (A, Z) \rightarrow e^- + (A, Z)$$

Muonic atom Single mono-energetic electron

$$E_e = m_\mu - E_{\text{recoil}} - E_{\text{binding}} = 104.97 \text{ MeV (Al)}$$

coherent recoil of nucleus

The fraction of coherent transition for Al $\approx 90-92\%$

$$R_{\mu e} = \frac{\Gamma(\mu^- + N(A, Z) \rightarrow e^- + N(A, Z))}{\Gamma(\mu^- + N(A, Z) \rightarrow \text{all muon captures})}$$

Experimental Signal:

Measured emitted mono-energetic (~105 MeV) electron from muonic atom

The COMET collaboration

JINR has been involved in the project since its establishment in 2008



43 institutes, 17 countries

Including five JINR member states
Belarus, Georgia, Kazakhstan, Russia, Vietnam

Still growing!

COMET at J-PARC



Joint Project between KEK and JAEA

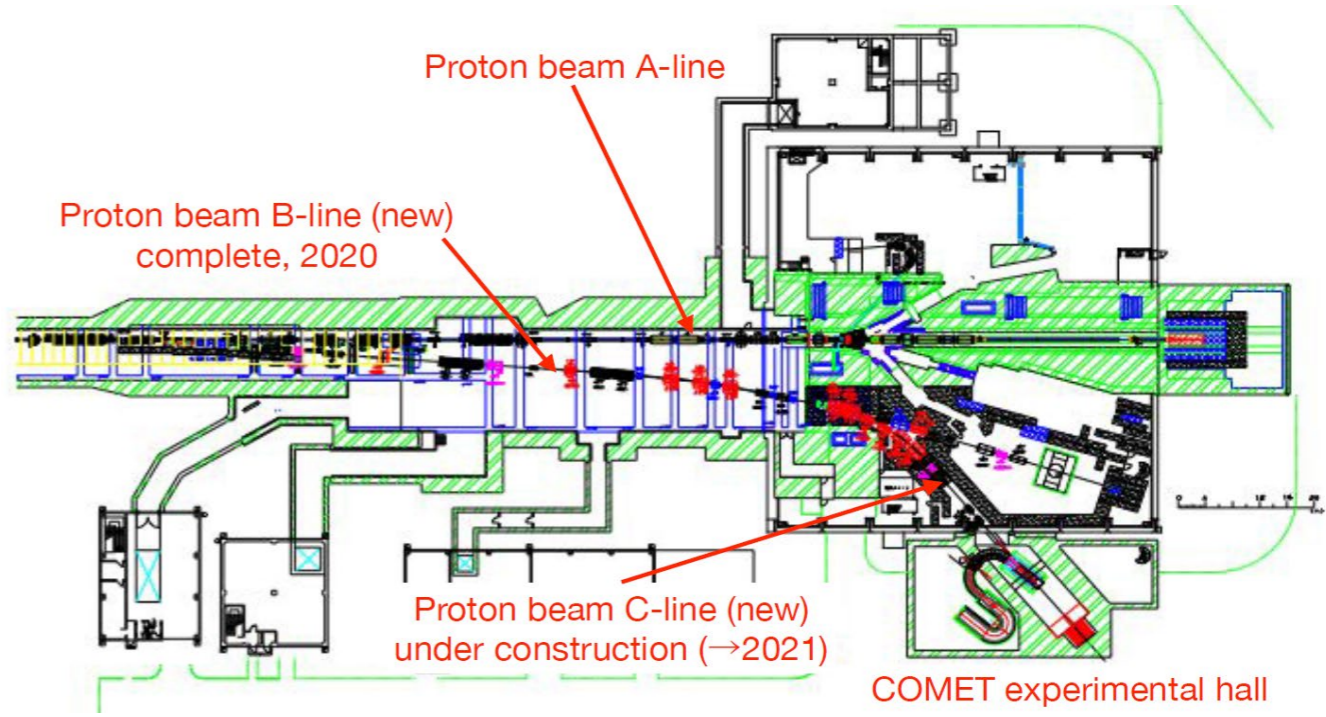

Two-phase realization

Phase-I

proton beam power = 3.2 kW

Single event sensitivity : 2×10^{-15}
 a factor of 100 improvement
 Running time: 0.4 years (1.2×10^7 s)

aluminium target

Phase-II

proton beam power = 56 kW

Single event sensitivity : 2.6×10^{-17}
 a factor of 10,000 improvement
 Running time: 1 years (2×10^7 sec)

Single event sensitivity : $O(10^{-18})$
 a factor of 100,000 improvement
 Running time: 1 years (2×10^7 sec)



Phase-I Goal

1 Search for μ -e conversion

- Search for μ -e conversion at the intermediate sensitivity which would be 100 times better than the present limit (SINDRUM-II) 2×10^{-15} . For this measurement used Cylindrical Detector System (CyDet)

2 Background Study for the full COMET Phase-II

- Direct measurement of potential background sources for the full COMET experiment by using the actual COMET beam line. For this measurement used Straw Tracker + ECAL (StrECAL)

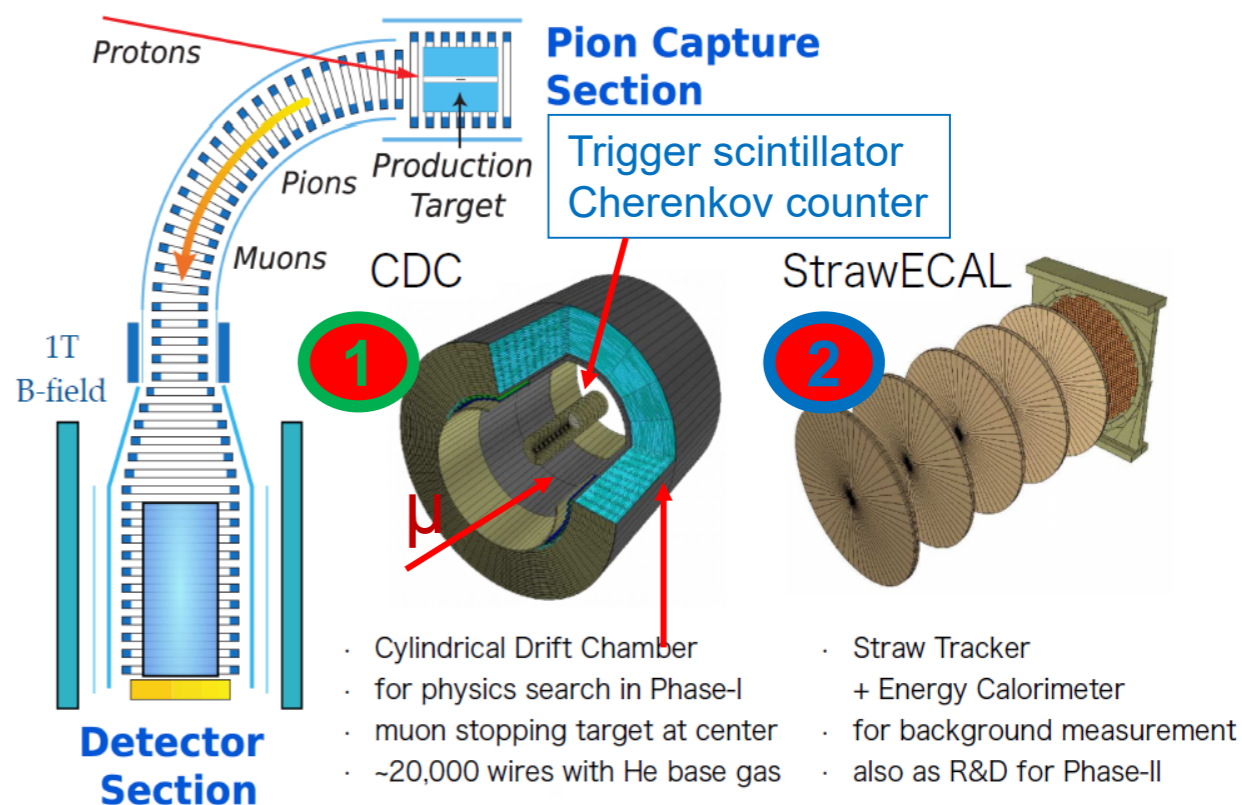

COMET Detector System and Requirements

Straw Tracker: 5 stations (Phase-I) ~2500 straw tubes, 9.75 mm diameter, 20 μm thickness, Ar:C₂H₆ = 50:50

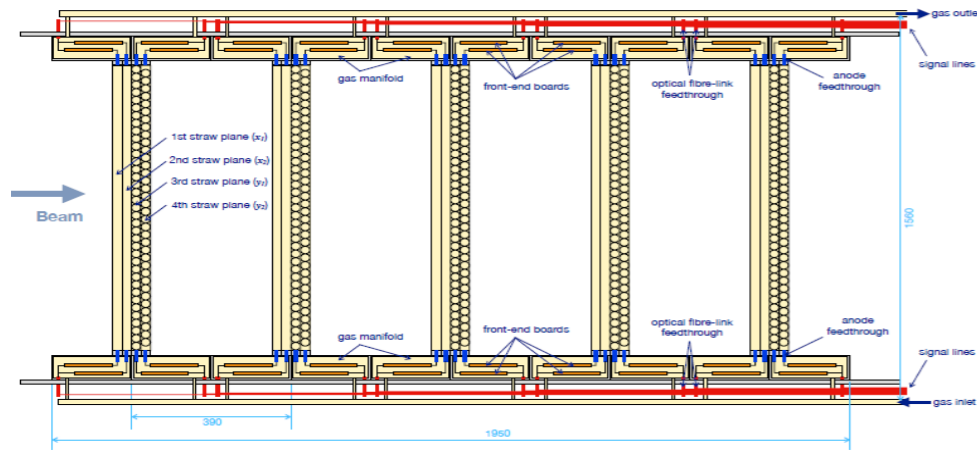

Requirements:

- Momentum resolution $\leq 200 \text{ keV}/c$
- Space resolution $\leq 200 \mu\text{m}$
- Work in vacuum, magnetic field of 1 Tesla

Electromagnetic calorimeter

ECAL (crystal type LYSO, Lu_{1.8}Y_{0.2}SiO₅Ce)

- Combination of ~600 LYSO crystals for Phase-I (for Phase-II 2272)
- Total size: diameter ~1 m
- Crystal size 20×20×120 mm³ (11 radiation length)
- Photon detector: APD

Requirements:

- < 5% ER at 105 MeV
- < 10 mm space resolution
- < 100 ns time resolution
- Work in vacuum, magnetic field of 1 Tesla

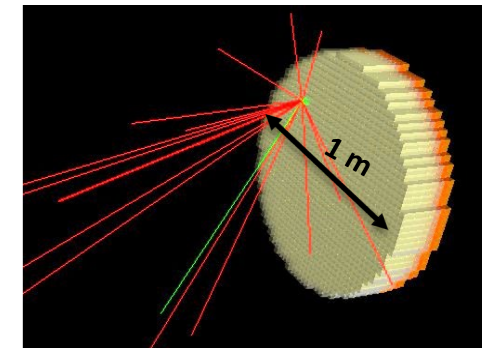

Front view

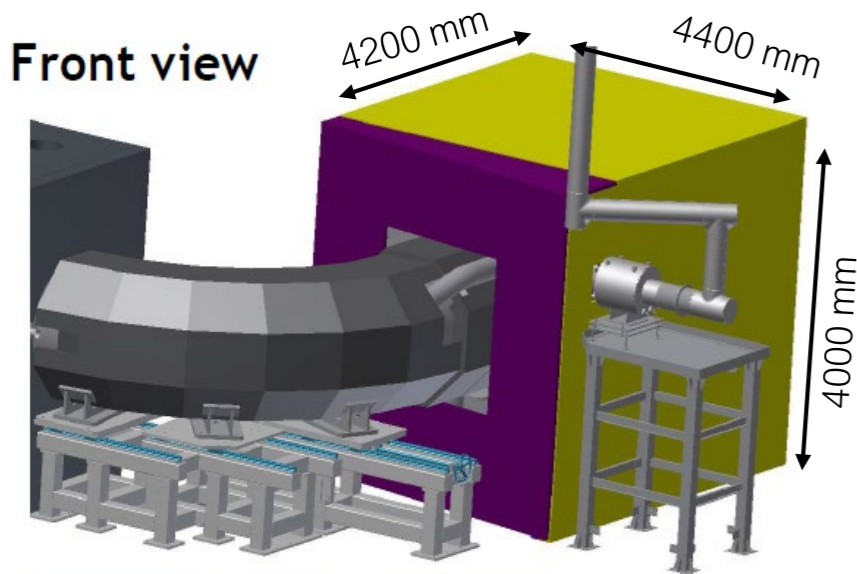

Cosmic Ray Veto (CRV)

Requirement: Efficiency $\geq 99.99\%$

CyDet (Cylindrical Detector)

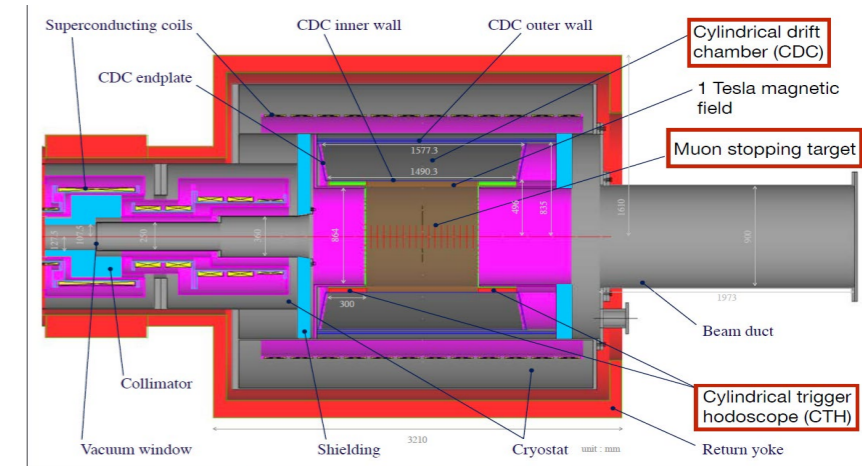

- Cylindrical drift chamber (CDC) surrounds the muon stopping target under 1T magnetic field

Requirements:

- Spatial resolution < 200 μm
- Momentum resolution < 200 keV/c

CRV two major parts: scintillator-based detectors (SCRV) and Glass Resistive Plate Chambers (GRPC).

The SCRV subsystem placed on top and back sides and based on extruded plastic scintillation strip with WLS fiber glued to the strip groove.

The GRPC will be placed in hottest area (Bridge Solenoid region) - active shield.

CRV consists of modules and covers Top, Back (Downstream) and Sides.

Cylindrical Drift Chamber (CDC) already at J-PARC

By 31 March 2022

- All necessary parts come to KEK.

Done!

- Cu pipes, flow meters, chillers ...

In April 2022

- Final assembling **Success!**

- Cooling tests **Success!**

In July 2022

- CDC disassembling **Done!**

On 14th Sep 2022

- CDC moved to Tokai. **Done!**

- Wire check **Done!**

Next steps

- Wire replacement Assembling:

Cabling, Electronics, Gas ...

- Cosmic-ray tests

19,548 wires in total: gold-plated tungsten wires with 25- μm diameter and unplated aluminum wires with 126- μm diameter for the sense and field wires, respectively

- Tension: 50 ... 80 g, or gravitational sags of 50 and 120 μm , respectively

- The cell geometry: 16.8-mm width and 16.0-mm height

To control the background

- **Intrinsic physics background**
 - Mostly from muon decay in orbit (DIO)
 - Calculated by Czarnecki with radiative correction. Branching ratio drops with order-5 function near end point.
 - Momentum resolution required to be better than 200 keV/c
- **Beam related background**
 - Energetic particles in beam with $E > 100 \text{ MeV}$
 - Mostly prompt. Can be suppressed by a delayed measurement window ($\sim 700 \text{ ns}$)
 - Some due to leaked proton. Proton extinction factor required to be $< 10^{-10}$.
actually achieved $\sim 10^{-11}$!
- **Cosmic ray background**
 - Cosmic ray: cover the system with cosmic ray veto detectors.
Required Inefficiency $< 10^{-4}$

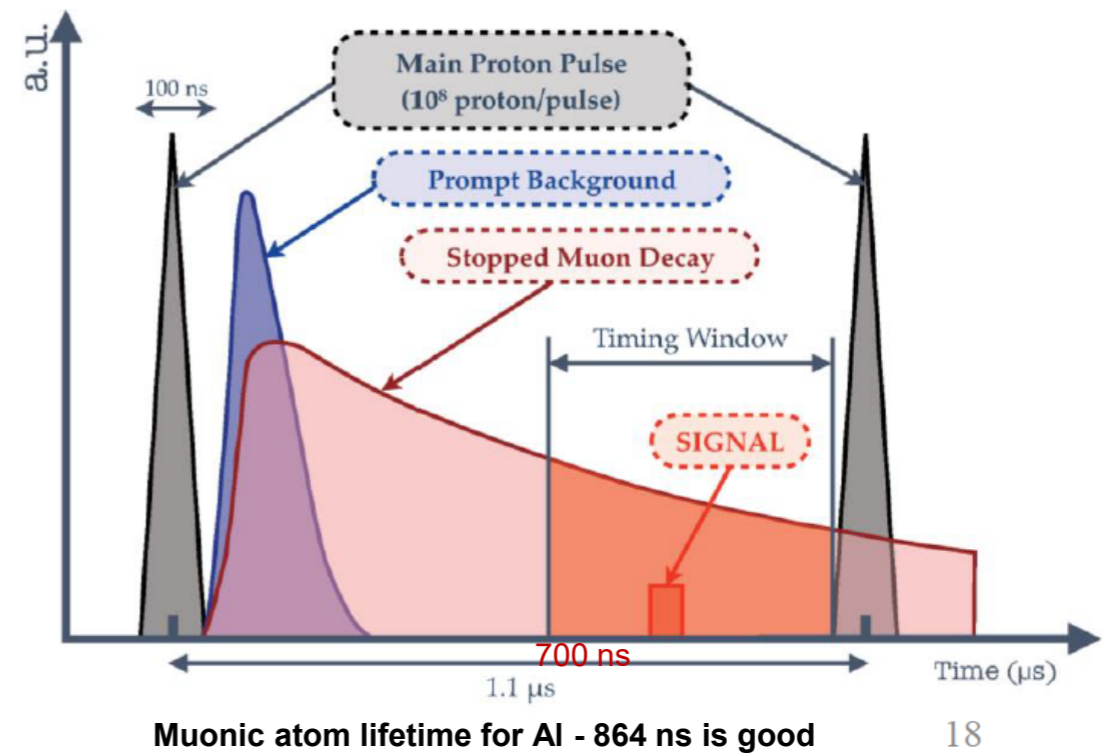
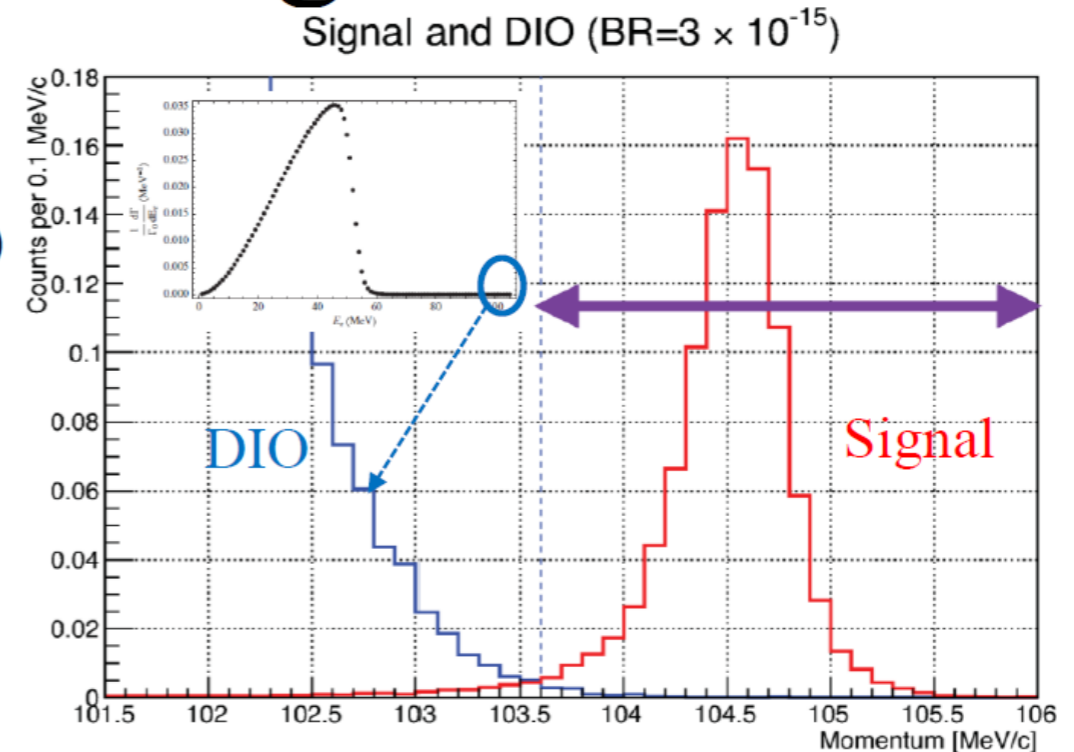

The estimated background events for a single-event sensitivity of 3×10^{-15} in COMET Phase – I with a proton extinction factor 3×10^{-11} are DIO: 0.01, RPC: 0.01, anti-protons: 0.01, cosmic rays: < 0.01 , Total: **0.032 events**

COMET Phase-I Sensitivity

Event selection	Value	
Online event selection efficiency	0.9	
DAQ efficiency	0.9	
Track finding efficiency	0.99	
Geometrical acceptance + Track quality cuts	0.18	
Momentum window (ϵ_{mom}) (a signal acceptance)	0.93	$103.6 < p_e < 106.0 \text{ MeV}/c$
Timing window (ϵ_{time})	0.3	$700 < t_e < 1170 \text{ ns}$
Total (Signal Acceptance for the μ-e conversion)	0.041	

$$B(\mu^- + \text{Al} \rightarrow e^- + \text{Al}) = \frac{1}{N_\mu \cdot f_{\text{cap}} \cdot f_{\text{gnd}} \cdot A_{\mu-e}}$$

Number of muons stopped inside targets
 $N_\mu = 1.5 \times 10^{16}$

Fraction of μ -e conversion to the ground state = 0.9

Fraction of muons to be captured by Al target = 0.61

3×10^{-15} (as SES) achievable in ~ 150 days

Comparison of Phase-I and Phase-II parameters

Parameters	Phase-I	Phase-II
Beam power	3.2 kW (8 GeV)	56 kW (8 GeV)
Running time	150 - 200 days	1 year
Target materials	graphite	tungsten
#protons	3.2×10^{19}	6.8×10^{20}
#muon stops (N_{μ})	1.5×10^{16}	1.1×10^{18}
Muon rate/s	5.8×10^9	1.0×10^{11}
#muon stops/proton	0.00052	0.00052
The detector acceptance ($A_{\mu-e}$)	0.06	0.04
S.E.S (single event sensitivity)	2.0×10^{-15}	2.6×10^{-17}
Measurement start	2025-2026	2028-2029

JINR group's contributions and responsibilities

1. Straw tracker
2. Electromagnetic calorimeter (ECAL)
3. Cosmic Ray Veto (CRV)
4. Software studies (simulations) for straw tracker, ECAL and CRV

Straw tubes mass-production for Phase-I

The complete set of tubes for Phase-I has been produced and tested:

- 2700 tubes of 20 μm wall thickness, $\text{\O} 9.8 \text{ mm}$, 120 and 160 cm length have been produced
- These tubes passed all the tests and have been sent to Japan

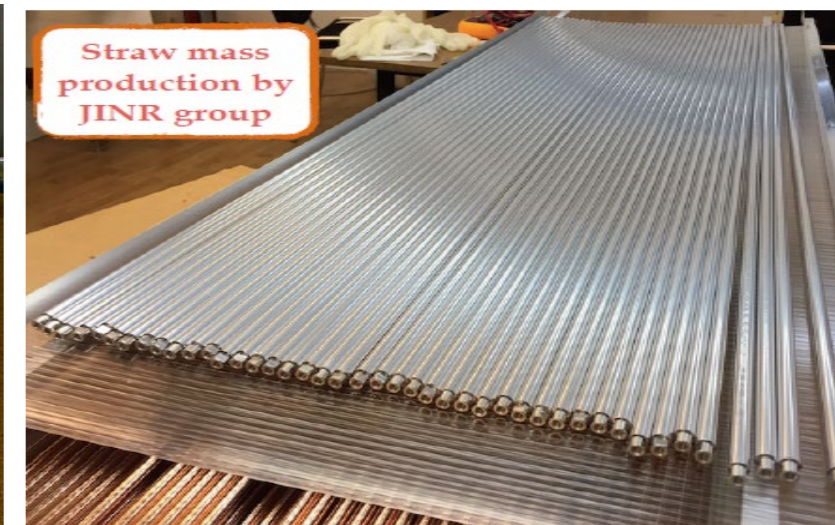
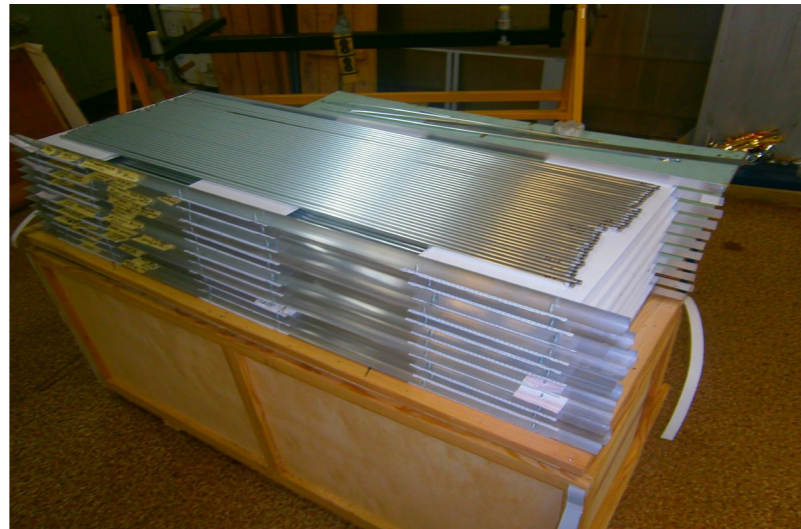

The study of the properties of straws

The following mechanical properties of the 9.8 mm straws have been measured:

- the range of elastic deformation of the straw
 - **Results: The limit value of the straw tension is obtained 1.85 kg (in COMET up to 1 kg)**
- the influence of temperature and the dependence of the elastic properties of the straw on its thickness
 - **Results: The maximum tension of the straw is provided at temperature from 10 to 20°C**
- The tubes aging
 - **Results: The service life of straw detector is 9 years**



J-PARC activities

Straw Tracker Status - COMET Phase-I

Straw-Tracker Assembly

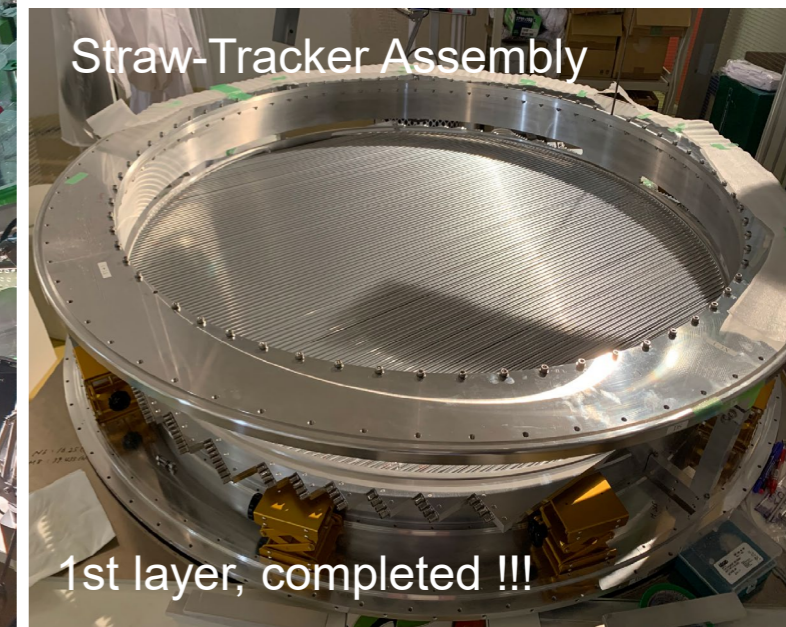

1st layer, completed !!!

- * First straw tracker module for Phase- α is on final stage of assembling
- * 480 straw tubes already glued into the frame and wired
- * Electronic boards ROESTI are ready for installing
- * After that is planned system gas leakage and vacuum tests
- * Within working visit all straw tubes were checked for quality, gas leakages and mechanical damages
- * **After 7 year All straws are in perfect condition and ready to be used for next modules**
- * Future activities include conclusion R&D of new 12 μm straw tubes and preparation for new mass production

The manufacturing area for straw-tube R&D at DLNP

For Phase-II we need even thinner and less diameter tubes: 5 mm diameter and 12 μm wall thickness
For this purpose we prepared a new straw production line in our laboratory

Completed real working machine for full dimension 12 μm thickness and 5 mm diameter straw tube production with controllable parameters

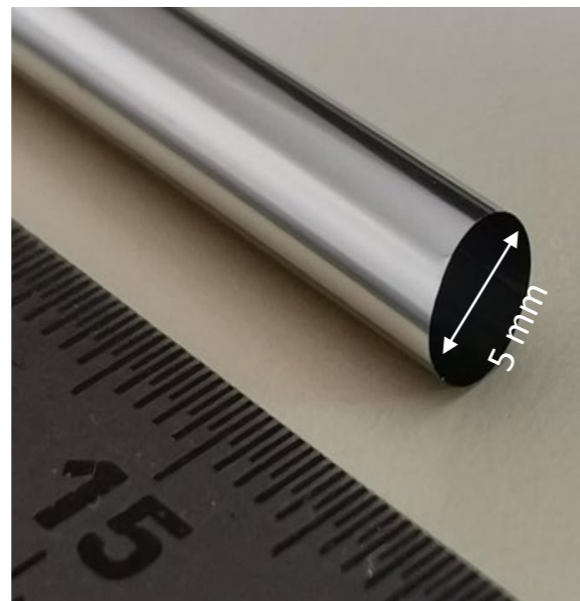
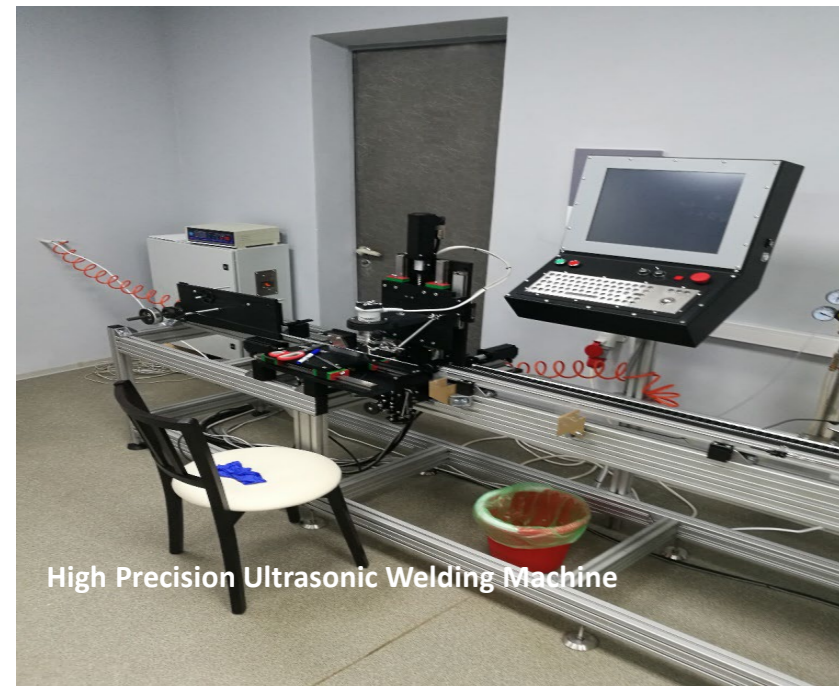

Cabability of the new straw tubes production facility

- 1) New welding machine design and 5-th class clean room with temperature and humidity control
- 2) **5 mm diameter and 12 μm** wall thickness straw tube production
- 3) Examination of straw quality control of tubes
- 4) Study straw tube properties
- 5) Precise measurements and monitoring of straw diameter with optical methods, accuracy of 0.1 μm

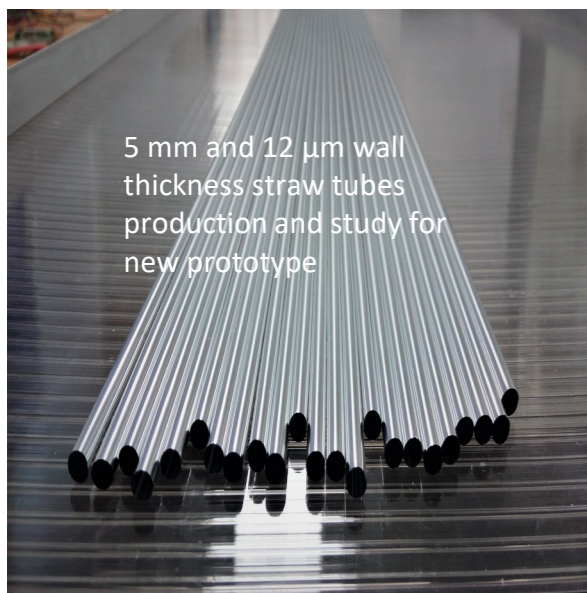

Produced straw parameters

- 140 pieces
- 70 cm in Length
- 4.98 ± 0.12 mm Diameter
- 12 μm Mylar tape thickness
- Aluminum layer 70 nm
- Prototype working pressure 1 bar
- Long term testing pressure 2 bar
- Max safe pressure 3 bar
- Max load pressure 4 bar

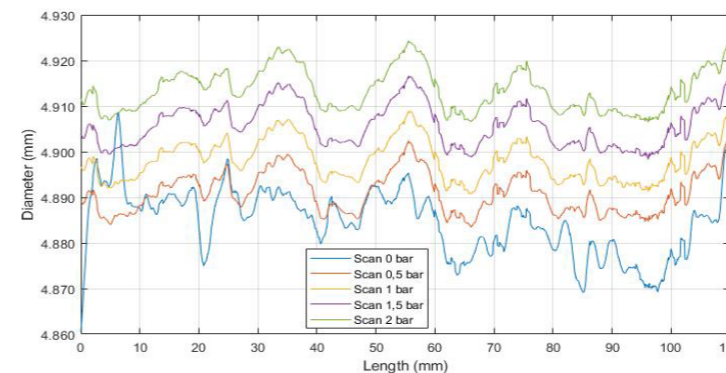

- Diameter scan along straw tube length with different inner pressures
- Diameter deviation along the tubes is less than **20 μm** ,
- Shape stays consistent under different pressures

- Long term tests still ongoing
- Straws stably staying pressurized
- No any mechanical damages
- After while Only 5% of straws dropped pressure

Great success in R&D, in the production of 5 mm diameter and 12 μm thick tubes

Straw tube tension versus humidity

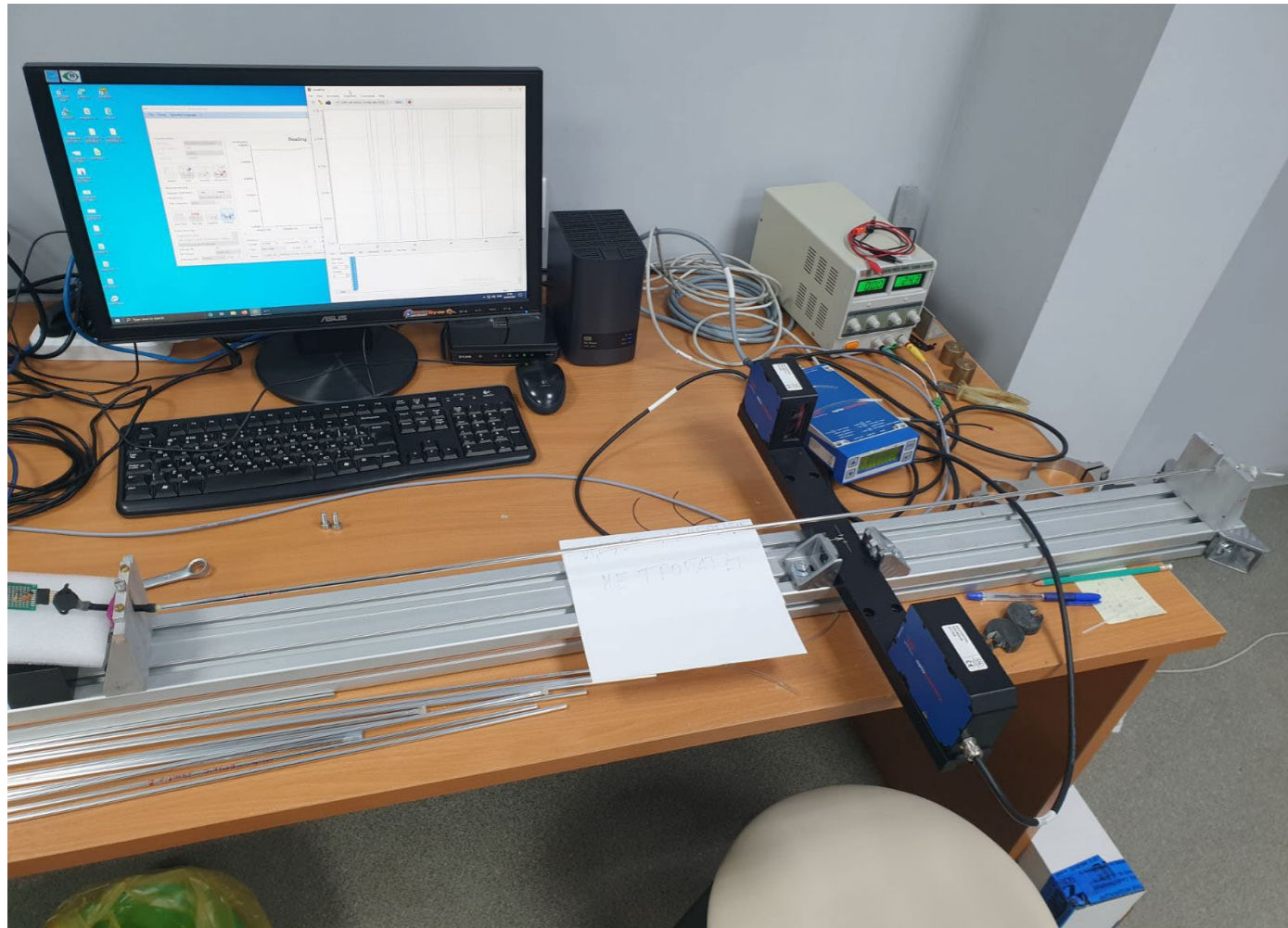

Main goal of this study is to see how humidity affects tension force and how well outside metallization can shield straw tube from it.

On picture below:

- Temperature (23.7 C)
- Humidity (Yellow)
- Mylar with one side metallization (Blue)
- Mylar with Double metallization (RED)

As graphs are showing, tension of both straws strongly depend on environment humidity. This study still ongoing.

64 channel prototype

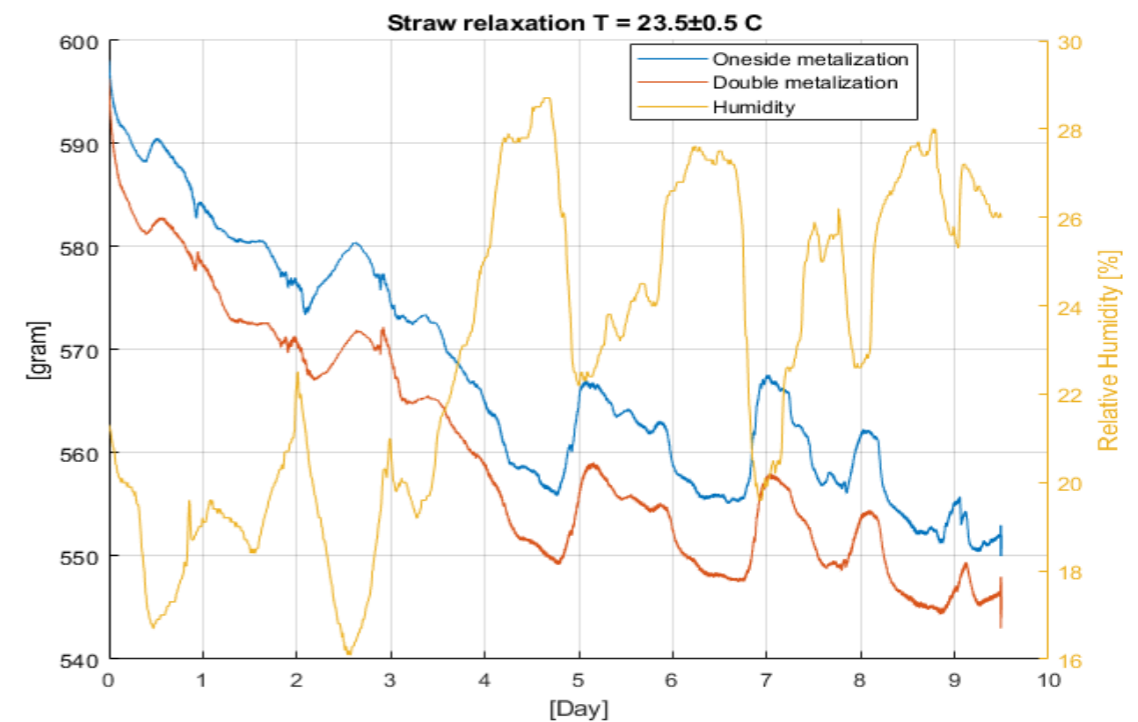

Electromagnetic calorimeter

Three candidates vendors

- **Saint-Gobain (SG), Baseline**
- OXIDE (OX), Japan
- Suzhou JT Crystal Technology (JTC)

Saint-Gobain has introduced an engineered version of LYSO which, compared to standard LYSO, offers up to:

- 6% improvement in energy resolution
- 20% higher light yield
- 20% faster decay time

Properties	Standard LYSO	Engineered LYSO
Density [g/cm ³]		7.1
Hygroscopic		no
Attenuation length for 511keV (cm)		1.2
Energy resolution [%] @ 662 keV*	8.5	8
Wavelength of emission max [nm]		420
Refractive index @ emission max.		1.81
Decay time [ns]	45	36
Light yield [photons/MeV]*	27600	33200
Average temperature coefficient from 25 to 50° C (%/°C)		-0.28

R&D of LYSO crystals The test bench has been prepared in DLNP

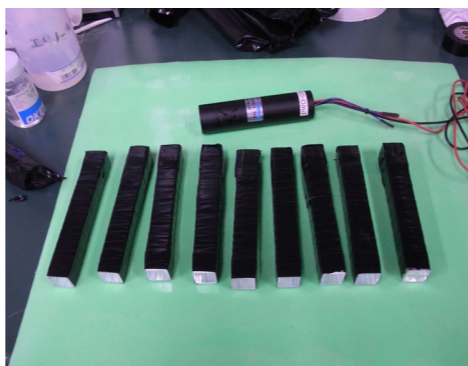

The LYSO crystal certification
More than 200 crystals have already been certified

- Simulation of processes in crystals, **ongoing**
- Comparison of the crystal types, **finished**
- Simulation of optimal structure of the calorimeter, **ongoing**
- Simulation of the calorimeter geometry in framework ICEDUST, **ongoing**
- Experimental study of the main parameters (uniformity, light output) LYSO crystals on a precision JINR stand, **ongoing**
- Calibration of 64 crystals of LYSO at the JINR stand for Beam Test (Tohoku), **finished**
- Participation in a calorimeter design, **ongoing**
- Quality control (certification) of all crystals in JINR (**full responsibility**), **ongoing**
- Calorimeter assembling, testing, calibration and installation at setup, **in the near future**

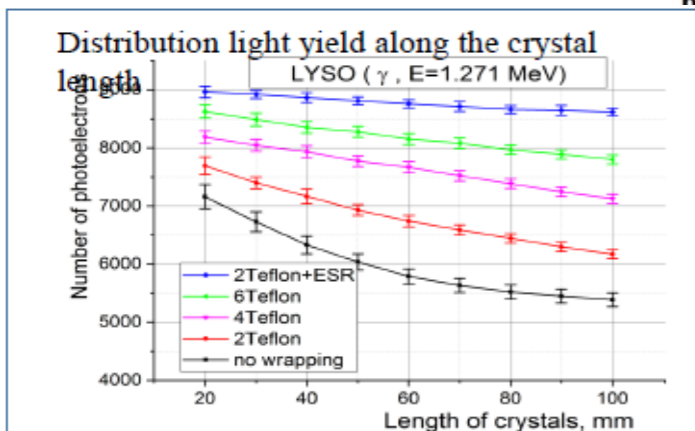
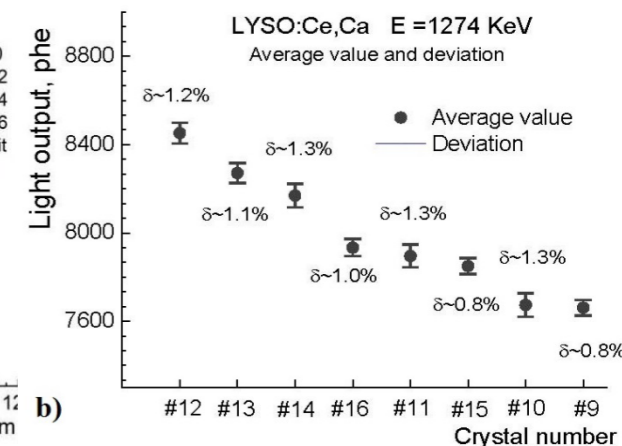
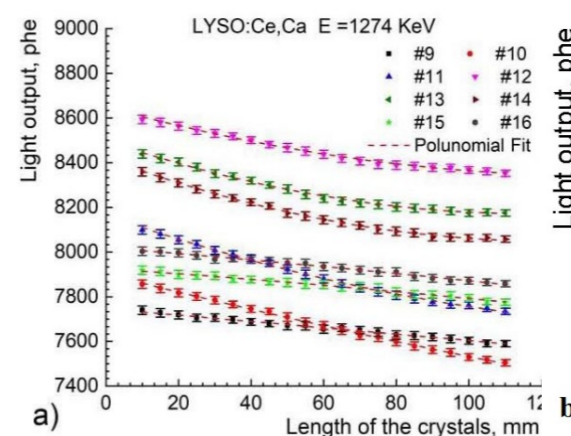
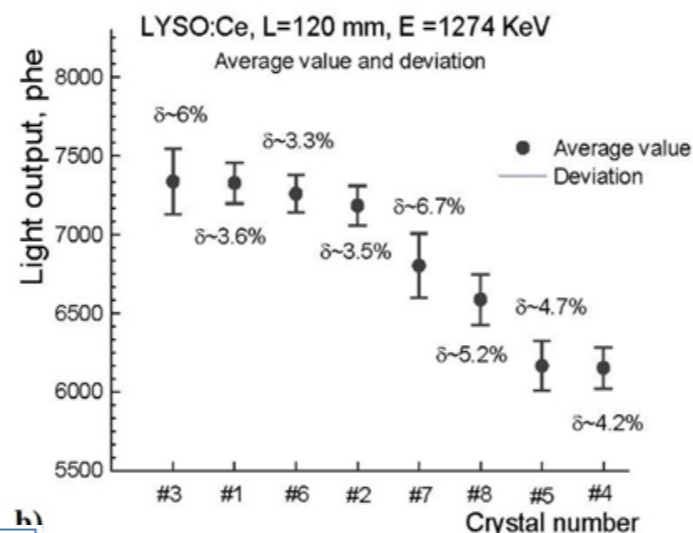
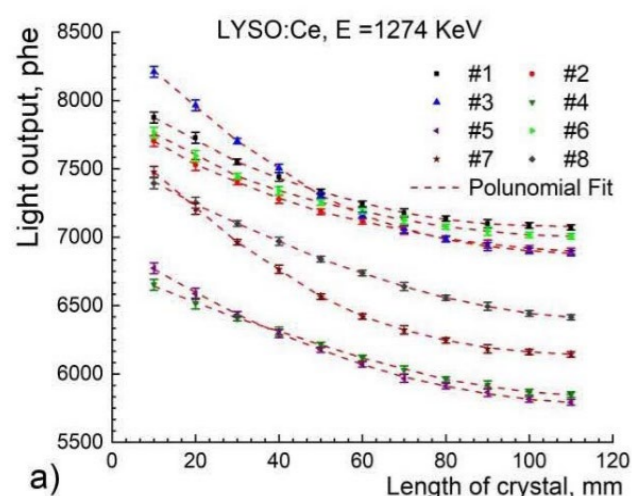

²²Na

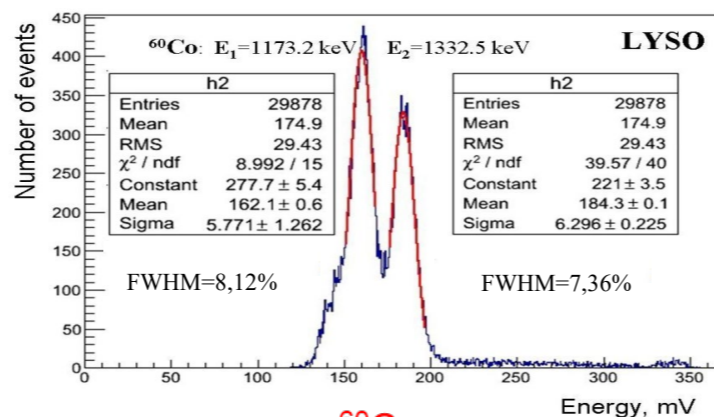

⁶⁰Co

Energy spectrum of a crystal with optimal wrapping

Crystal	Energy resolution, %		Mean value of scintillator response non-uniformity, %
	511, keV	1274, keV	
LYSO:Ce	9	8,5	4,6
LYSO:Ce,Ca	6,4	6	1,1

Wrapping		Energy resolution (L= 60 mm), [%]	
1	Without wrapping	60	11.37
2	2Teflon	74	11.44
3	4Teflon	79	10.59
4	6Teflon	83	9.5
5	2Teflon+ESR	~98,5	8.1

Light yield non-uniformity along the crystal length for various types of reflective materials

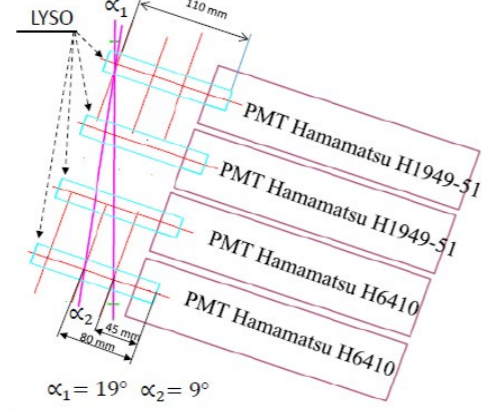
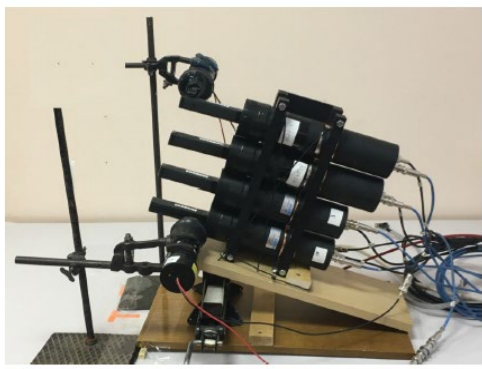

Crystals: LYSO - 4
Wrapper
 Two layers of TEFLON
 - Thickness = 65 μm
 - Absorbance 28 %/cm
 One layer of ESR film
 Thickness = 65 μm
 Refl.Coeff. = 0,99/0,1
 One layer of paper
 Thickness = 200 μm

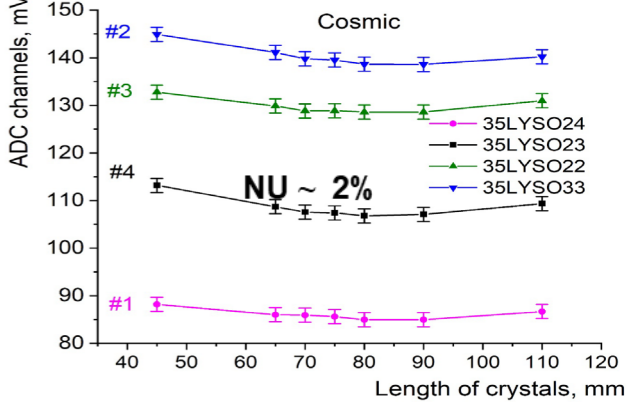
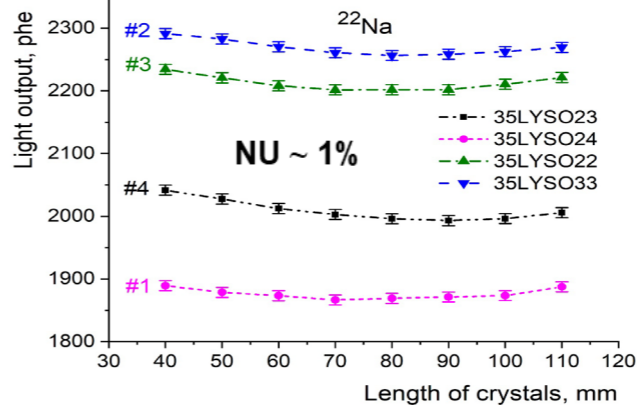

Non-uniformity of the LY along the crystals length, measured at an energy of 511 keV

Non-uniformity of the prototype response along the crystals measured using cosmic muons

a) Measuring setup

b) Measurement scheme

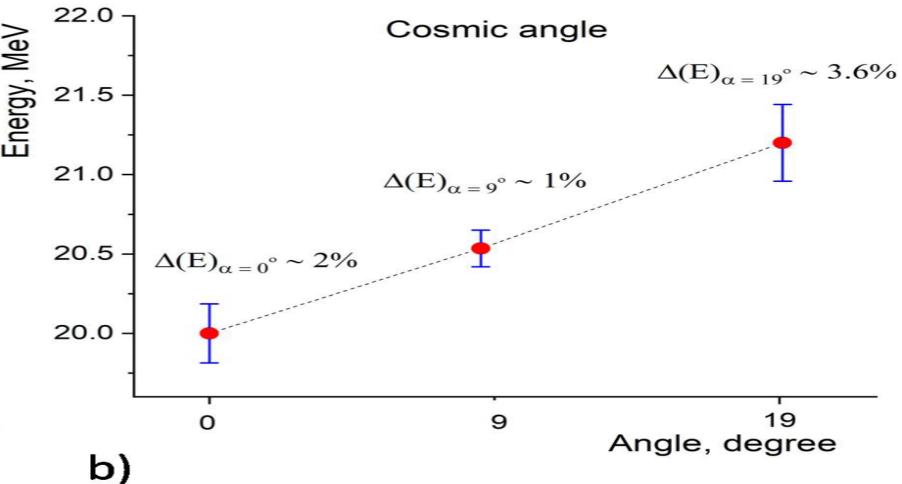
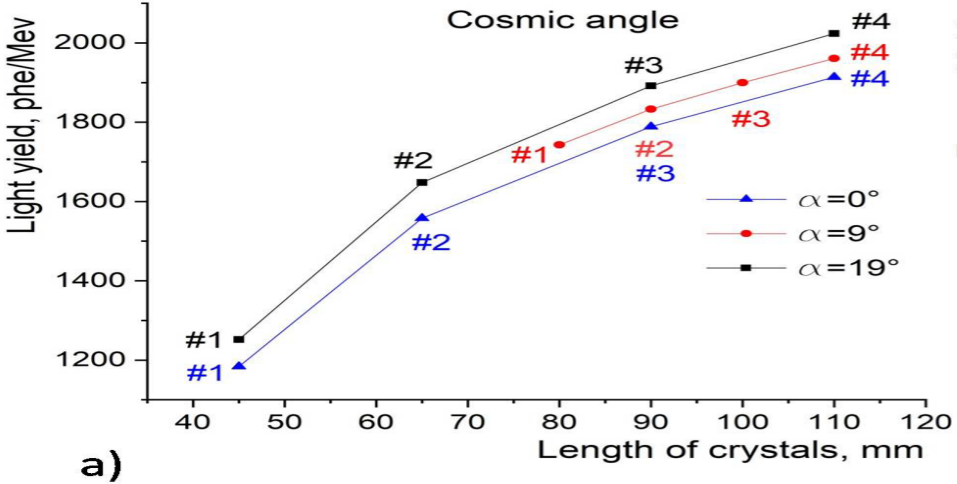

a) Scintillator responses of the calorimeter prototype for angles of 0, 9 and 19 degrees ; b) Detector response non-uniformity for angles 0, 9 and 19 degree

G4 simulation of the LYSO calorimeter: energy resolution

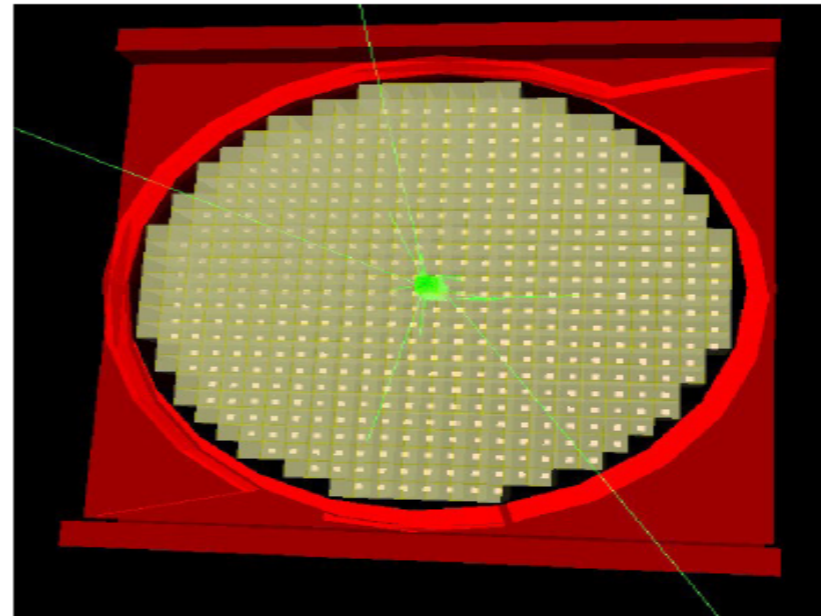
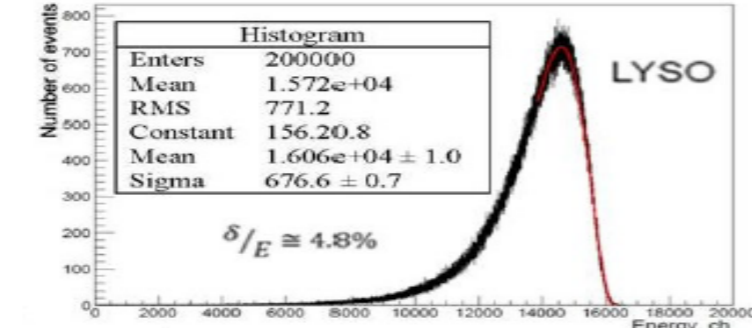
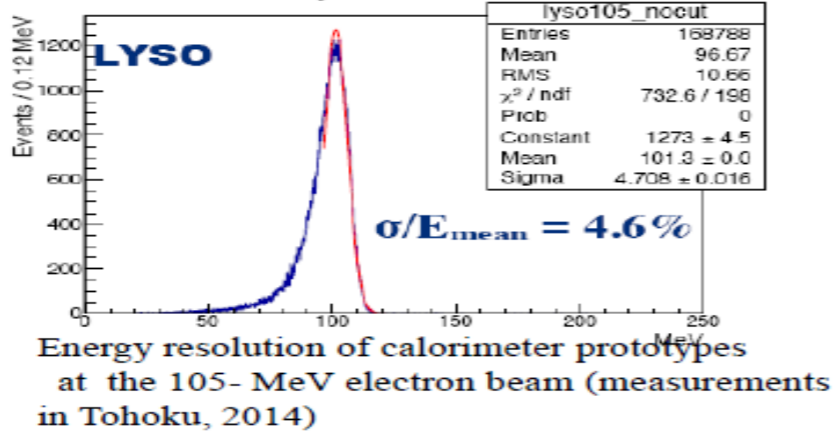

G4 simulation of the LYSO calorimeter for the COMET experiment

StrECAL system integration tests at ELPH in Tohoku

Energy range: 65 -145 MeV

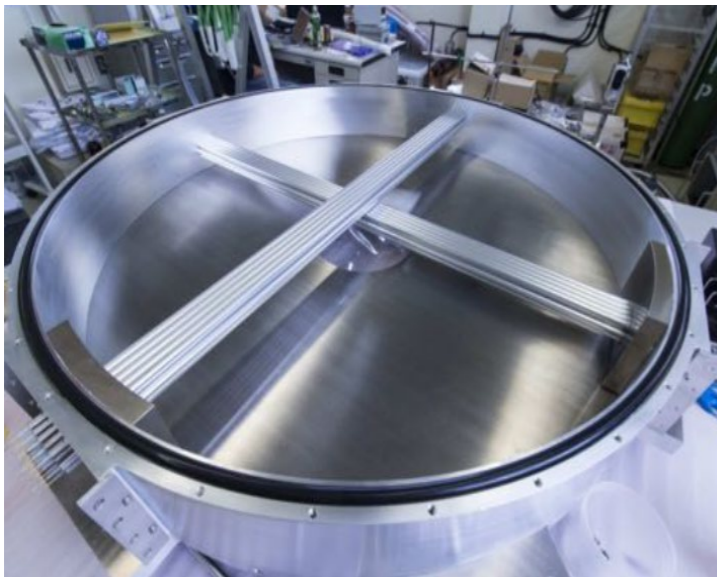

Straw prototype

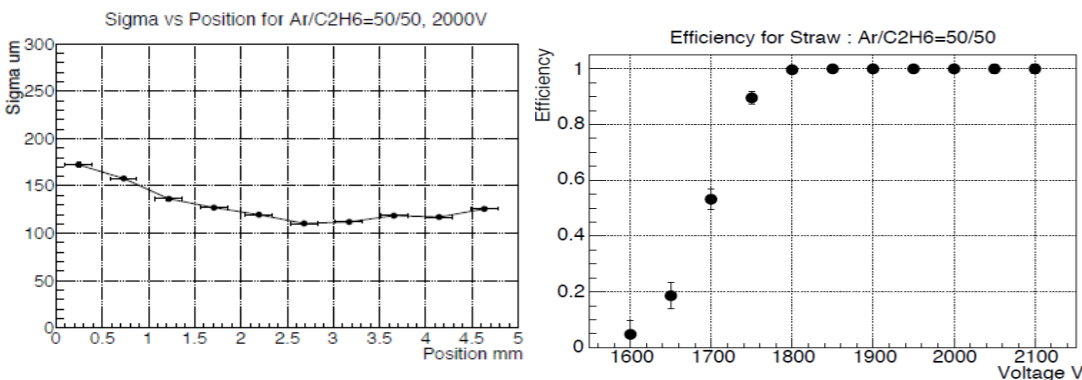

The results of straw efficiency and spatial resolution HV 1800- 2000) for Argon/Ethan

- $\epsilon > 96\%$
- $\sigma \sim 119 \mu\text{m}$
- Momentum resolution $\sim 180\text{-}200 \text{ keV}/c$

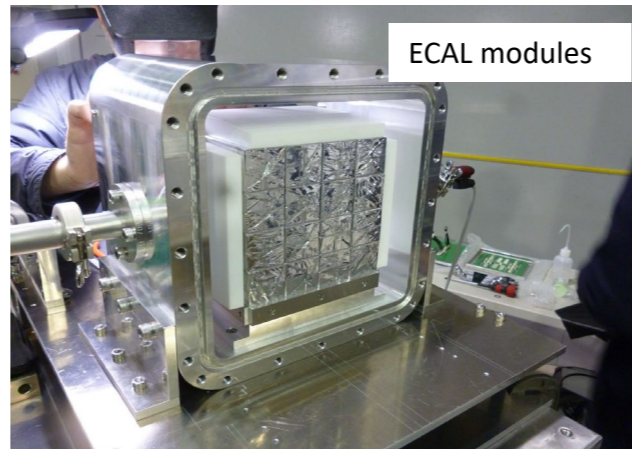

ECAL prototype 64 (8x8) JINR cryst.

The position resolution is 5.8 mm

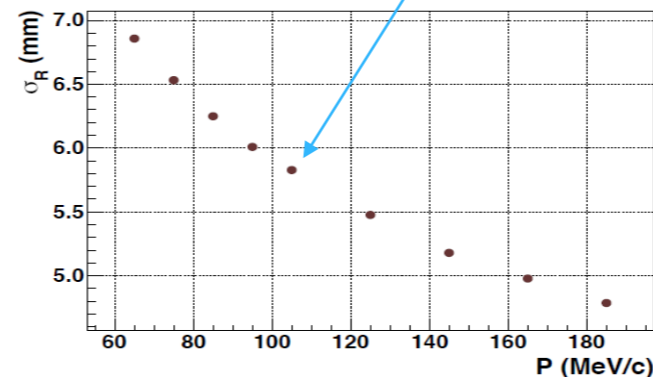

The position resolution varying from 5.3 mm to 8.5 mm, depends on where electron hits (center, border, corner)

- The energy resolution at 105 MeV for
- GSO - $5.5 \pm 0.02 \text{ (stat)} \pm 0.04 \text{ (syst)} \%$
 - LYSO - $4.91 \pm 0.01 \text{ (stat)} \pm 0.07 \text{ (syst)} \%$

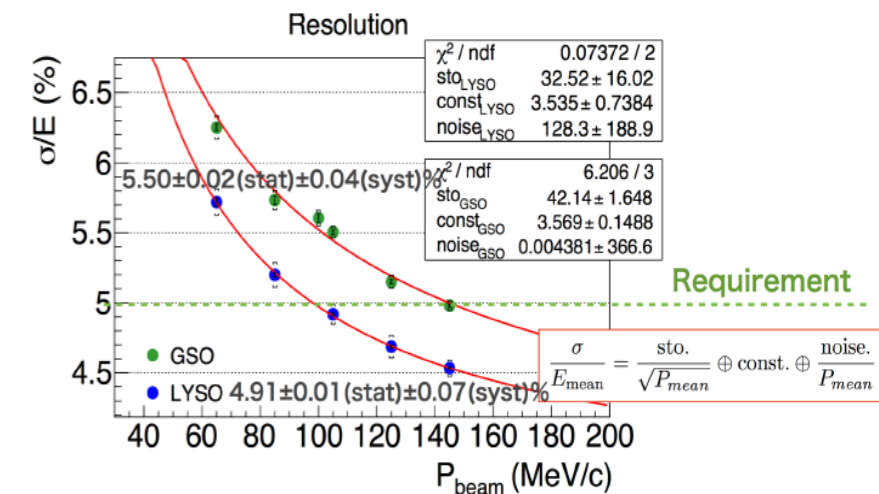

At 105 MeV/c, the energy resolution varying from 3.8% to 4.8%, depends on where the electron hits (center, border, corner) on the ECAL

The results of ECAL prototype test

- Energy Resolution 4.8% @105MeV
- Position resolution < 10 mm @105 MeV
- Timing resolution < 1.0 nsec

The results of StrECAL system integration beam tests meet all the requirements of the experiment

Cosmic-Ray Veto (CRV)

- Muons from cosmic rays mimic the 105 MeV conversion electrons and, as a major source of background, would reduce the experiment overall precision. So, to suppress the cosmic muons, the Cosmic-Ray Veto (CRV) system becomes as an essential part of the COMET experiment. It will cover around of the COMET other systems and will acting as an active shielding and efficiency to record the muon is required on 99.99% level.
- CRV will consist of two major parts: scintillator based (SCRV) and GRPC based (GRPC-CRV) subsystems. The SCRIV subsystem placed on top, sides and back of the COMET and based on extruded plastic scintillation strip with WLS fiber glued to the strip groove. The GRPC-CRV will be placed in hottest area at front of the COMET and will be consists of array of GRPC.
- The JINR group is the leader in R&D, in design and in development of the SCRIV subsystem. This activity includes two parts: to finalize design of the SCRIV with providing scintillation strips production, testing, CRV modules creation schedule and to design/create/test the electronics embedded to the scintillators.
- We proposed the final designs of the strip and CRV module were discussed during the COMET Collaboration Meeting 34 and 35 and it was approved for SCRIV-LS-0.
- First 3.2 meter long CRV module already created and sent to J-PARC

Scintillation strips as a base element of the COMET SCRIV modules

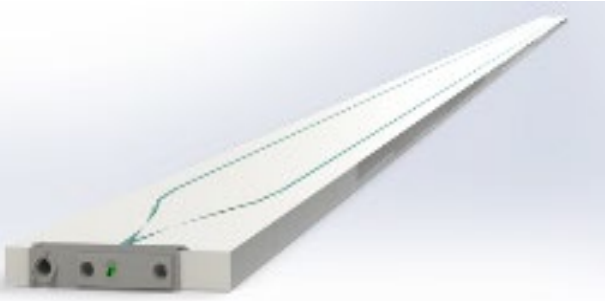

Design of the strip

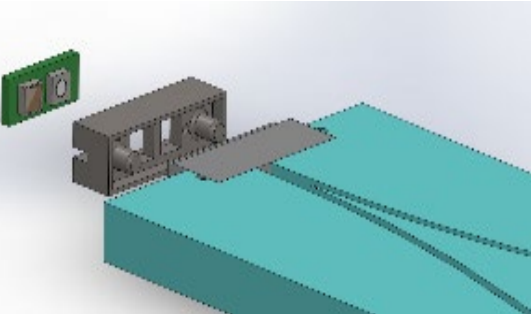

Sketch of the strip with SiPM board and housing. The real look of the SiPM PCB inserted to the housing



real strip

We investigated the different configurations for strips: with one or two Wave-Length Shifting (WLS) optical fiber in parallel grooves, with different WLS fibers diameters, combination of it.

- The investigation included a search of the best values for the shift layer to each other (so called pattern) by simulation with GEANT-4 and it tested on 4x4 module.

- We found the reasonable compromise between the strip's geometry, number of WLS fibers, its diameter and SiPM type should be attached

- design of SCRIV based on 4-layers array of plastic scintillator strips of 7x50 mm² in cross section and with two 1.2-mm (for sides) and 1.4-mm (for top) in diameter WLS fiber glued in the groove along the strip

- With this geometry it will be possible to achieve required up to 99.99% efficiency for cosmic muon registration.

- The light collection will be done with Hamamatsu MPPC/SiPM S14160-3050HS since it have up to 50% of quantum efficiency on required green light area thus ensuring maximum efficiency of the strip to detect the cosmic muons

Strips test stand

Layer	left	Top mount point view																right
		1	2	3	4	5	6	7	8	9	10	11	12	13	14	15	16	
Top, L4	78	31	56	68	40	52	8	36	46	6	27	29	9	12	38	48		
Middle, L3	97	33	50	47	58	35	37	53	2	39	43	11	23	4	21	70		
Middle, L2	63	61	64	57	25	18	42	7	28	1	96	3	13	14	99	45		
Bottom, L1	55	54	80	67	59	26	5	10	17	49	30	32	15	24	98	22		

64 for strips order for first CRV module



Test stand full assembly



CRV module assembly and preliminary test on cosmic

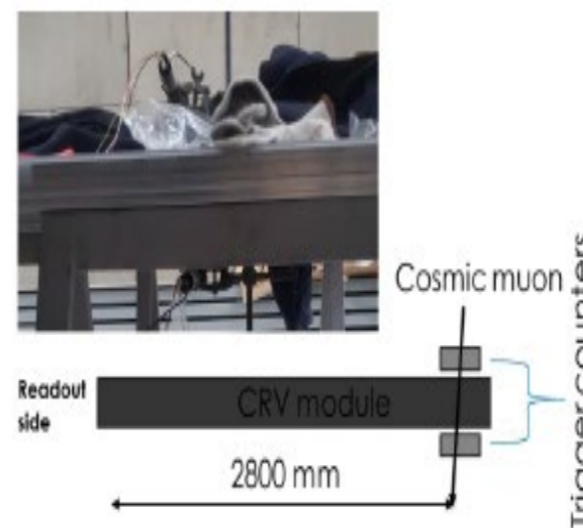
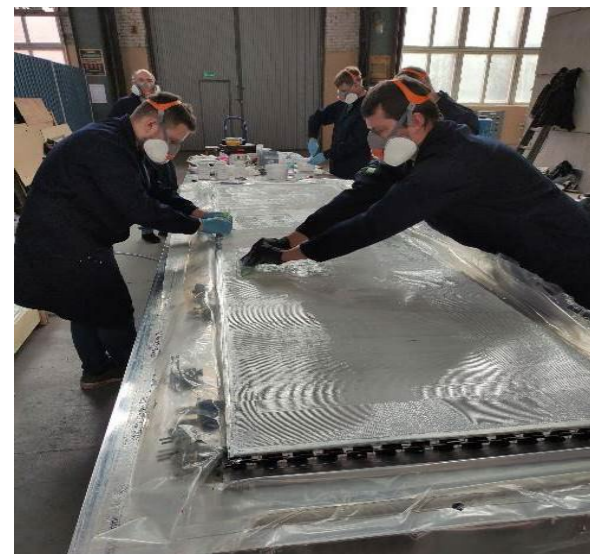
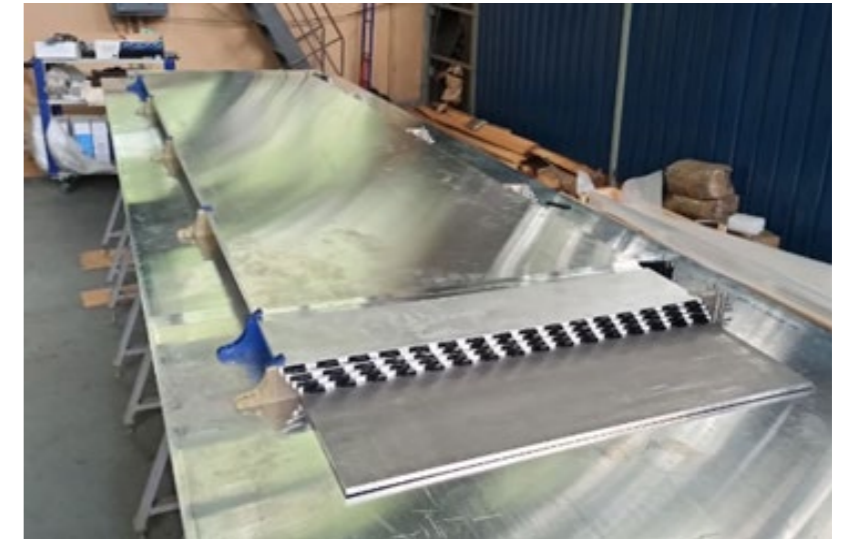
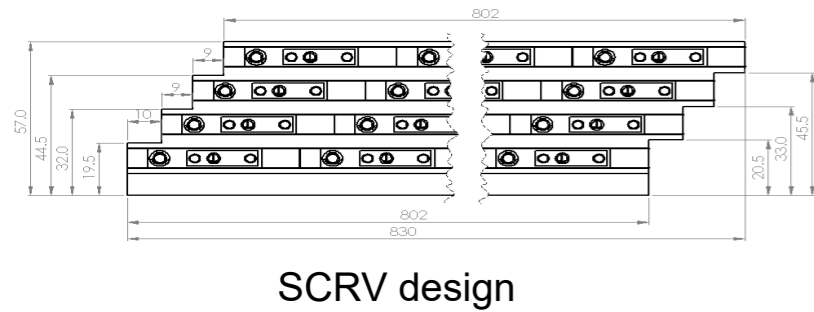

Assembly of CRV module

First test of CRV module provided at JINR

CRV module ready to send

➤ We proposed the final designs of the strip and CRV module were discussed during the COMET Collaboration Meetings it was approved for SCR-LS-0.

Schedule of works on the project in 2025-2029

- Participation in the preparation, engineering and physics run, the data acquisition and analysis of Phase-I, 2025-2027
- Simulation of a complex detector system (tracker, calorimeter, etc.), 2025-2027
- R&D program for the production of straw tubes with a wall thickness of 12 μm and a diameter of 5 mm
Measurement of all mechanical properties and development of quality control standards for manufactured new straw tubes of diameter 5 mm, 2025
- Completion of assembly, testing, calibration, installation, cosmic test and maintenance of the straw detector for Phase-I, 2025-2026
- Production of straw tubes (about 1000 pcs) for a full-scale prototype, 2026-2027
- Production of a full-scale straw station at JINR, with new tubes (12 μm , 5 mm), and measurements on the beam, 2027-2028
- Preparation, mass-production and testing of straw tubes for Phase-II, 2028-2029
- Development and optimization of the crystal calibration method for the COMET calorimeter, considering the features of the experiment: the presence of magnetic field and high-resolution calorimeter, 2025-2026
- Participation in the design, assembly, installation, cosmic test and maintenance of the calorimeter in full, 2025-2027
- Participation in the assembly and maintenance of the CRV for Phase-I and Phase-II, 2025-2029
- Participation in the beam tests of detector components for Phase-II, 2028-2029
- Participation in the assembly, testing, installation and maintenance of the entire detector system for Phase-II, 2028-2029

JINR's responsibility in the COMET experiment

- The JINR group is the only one within the COMET collaboration capable of producing thin-wall straw tubes, so we are **fully responsible** for their production. Various procedures have been updated to check tubes for pressure, gas leakage and elongation in accordance with COMET's requirements, and new testing standards have also been established.
- JINR takes **full responsibility** for the next step in this direction by carrying out R&D work on straw tubes for the COMET Phase-II, with a diameter of 5 mm and a wall thickness of 12 μm . For this purpose, we have prepared a new straw production line in DLNP.
- JINR physicists, together with KEK colleagues, take **full responsibility** for assembling, testing and installing the full-scale straw tracker for Phase-I. Appreciating JINR's crucial contribution to the creation of the straw tracker, the collaboration has elected a member of the JINR-COMET team to be one of the **coordinators for the straw tracker system**.
- JINR proposed the idea and took **full responsibility** for the production of a full-scale straw station for Phase-I, with a new type of straw tubes.
- JINR takes **full responsibility** for the development and optimization of the crystal calibration method for the calorimeter to be used in COMET Phase-I and Phase-II.
- JINR, together with KEK and Kyushu University, takes **full responsibility** for assembling, testing, installation and operation of the calorimeter.
- JINR physicists take **full responsibility** for crystal certification and are leaders in R&D work.
- JINR physicists implemented a full-scale R&D program to create a cosmic-ray veto system. The program was successfully completed, and the results were presented at collaboration meetings. Based on these results, all parameters and methods for creating the CRV were determined. Also, the **main responsibility** for the assembly, testing and installation of the CRV for Phase-I will be on JINR scientists. As a result, a member of the JINR group was elected the **COMET-CRV leader**.

COMET Phase-I Facility Construction Schedule

Detector Schedule

- CyDet will be ready by **the end of June, 2025**
- StrEcal should be ready by **the end of January, 2025**
- CRV should be ready by **the end of September, 2025**

COMET Phase-I is ready at **March, 2026.**



Conclusion

- The COMET is a search experiment for μ -e conversion at J-PARC
 - aiming improvement the sensitivity x 10,000 better than the past limit, 1.0×10^{-17}
 - staging approach called **Phase-I** / Phase-II
- **COMET Phase-I** is under construction
 - Phase-I Goal: 2.0×10^{-15}** Up to 10^{-15} → sensitive to “new physics”
(in 150 days operation)
 - The creation of CDC detector for physics search is already finished
 - The other system is under construction
 - **We plan to be ready in the beginning of 2026.**
- In parallel preparation and carrying out Phase-I, will go work on creation of a full muon bunch, R&D for COMET Phase-II is underway. Expecting to start in **2028-2030**
- JINR plays a **leading role** in the preparation and implementation of this fundamentally important experiment.

Thank you for attention!

BACKUP

PRISM (=Phase Rotated Intense Slow Muon source), PRISM/PRIME

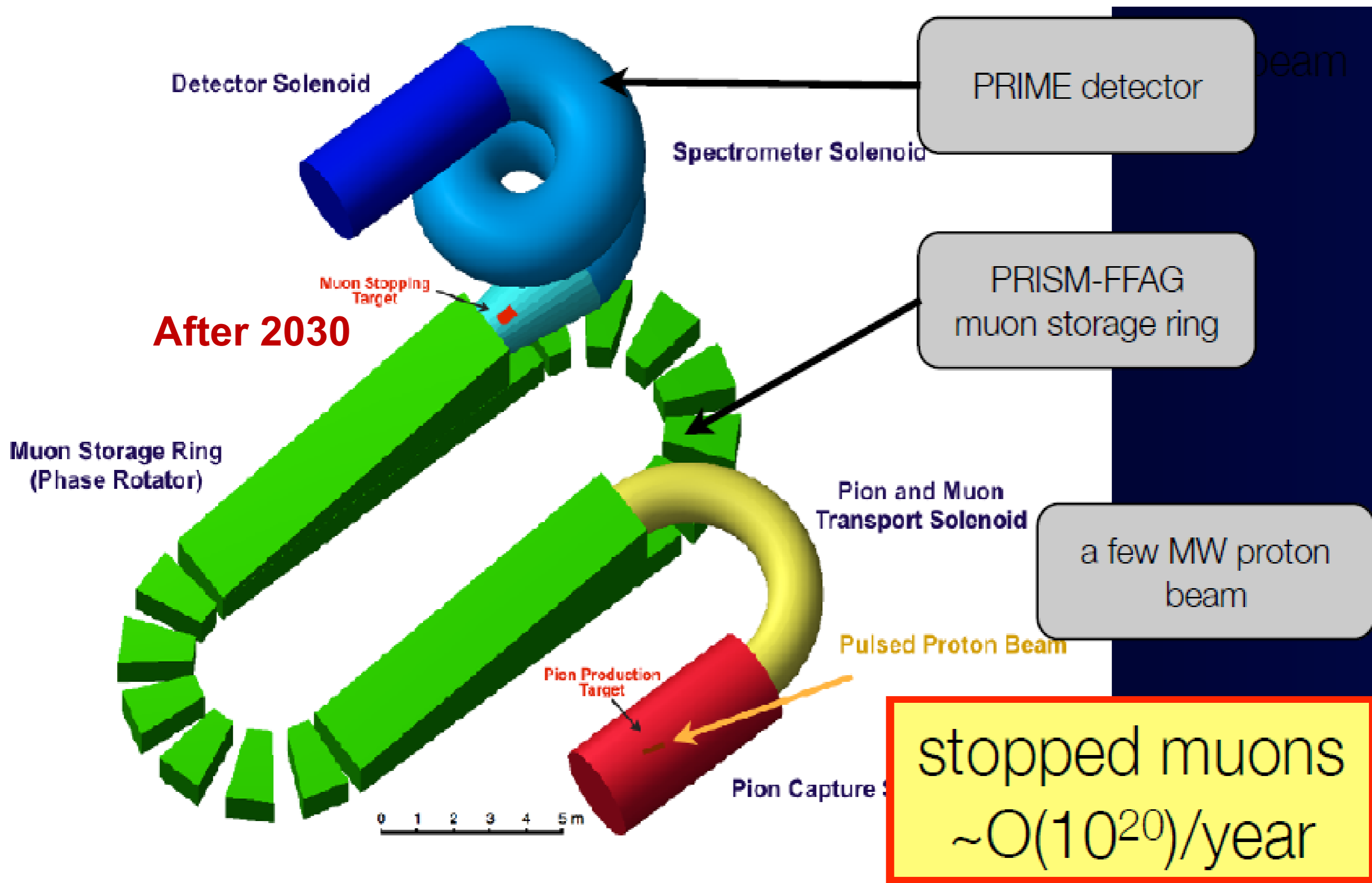

Mu2e Run 1 Timeline

Closed caption box size

Mu2e Timeline

- Mu2e Project is fully funded and 85% complete
- High priority and high level of support from Fermilab
- Aiming for Project early completion date Dec 2025
- Begin Run 1 data taking mid- CY2026 - for about 6 months of data collection

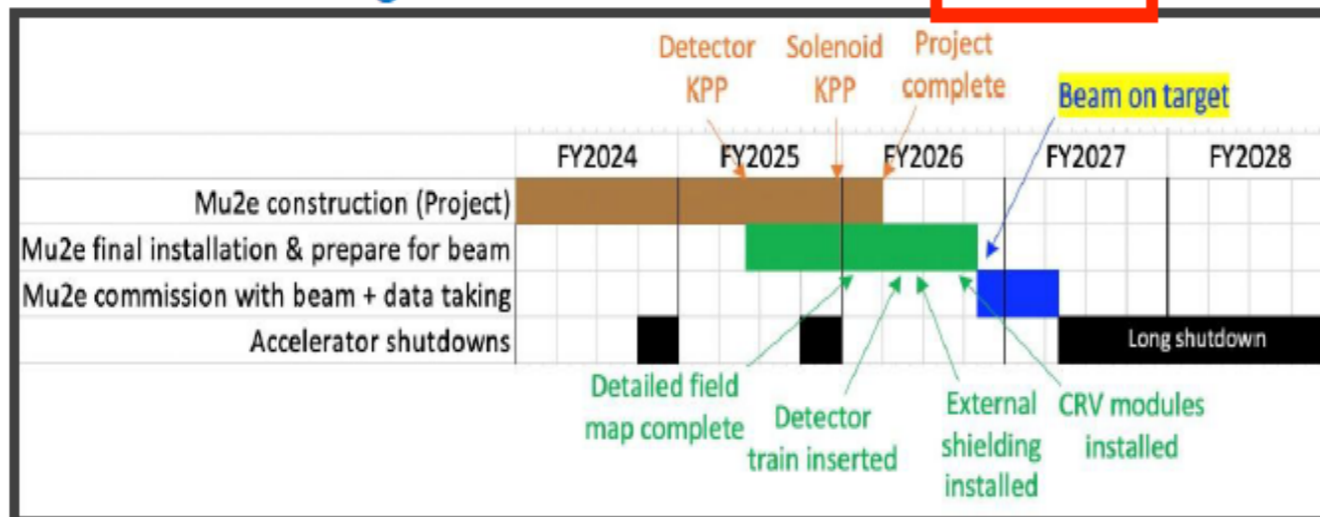

- Resume data collection after shutdown and collect data for 4 years
- Request P5 endorsement of physics and for operations and collaboration support

Run 1
August 2026 -
April 2027

Run 2:
FY2029-FY2032