

SPD ECAL Status Report in September of 2024

Oleg Gavrishuk, Laboratory of High Energy Physics, Dubna

- 1. Matrix Form for new scintillator production (40x40x1.5 mm³) - ready**
- 2. Scintillator tiles production (Vladimir, Uniplast) – 160000 – plates 40x40x0.5 mm³ - ready**
- 3. Stamp Form for Lead :**
 - 1. Design and documentation is read**
 - 2. Production began in August 2024**
- 4. Scintillator tiles delivered in Dubna**
 - 1. Test and paint edges in LVHE – in progress**
 - 2. Test and paint edges in LNP – in progress**
 - 3. Modules assembling in LVHE & LNP - in progress**
- 5. WLS Tver - purchase 200 m, (8.75USD/m) 1750 USD – Selunin, Ribnikov at all.**
 - 1. Test was done in LNP – Results: Baranov V. report - not better of Kuraray**
 - 2. MC – Zimin Iliya – WLS att. length influence on EC Resolution**
- 6. Lead absorber 0.5 mm Ccu (Pb 99.4% + Sb 0.5% + 0.1% metals):**
 - 1. Manufacturing plates for Modules 80x80 (4 cells) – in progress in LVHE**
 - 1. Using milling machine – Vitaliy Azorsky – 400 plates should be ready soon**
 - 2. Manufacturing plates for stamp – 85x168x0.5 mm 40.000 should be done in September-October 2024**
- 7. WLS Fiber preparation – Not solved – polishing – painted**
- 8. ADC and Frontend electronic – status not defined yet – responsibility – Anfimov**

Cost of 2024:

1.	Matrix form for Scintillator - 2600000 Rub	– 26000 USD
2.	Stamp for Lead - 180000	– 18000
3.	Lead Ordered 450 kg	– 4000
4.	Material and tools	– 5000
5.	WLS - ordered in Tver	– 1750
6.	Lead - need to buy – 800 kg (8 USD/kg)	– 12000 USD
7.	Production – 14 Rub/plate - 560000 Rub	– 6000 USD
8.	Total	– 56550

Numbers for 2024

1. Scintillator plates: 160000 ps – ordered already
2. Cells: $N_{\text{cells}} = N_{\text{sc}}/200 = 800$ ps – possible assembling in JINR
3. Modules: $N_{\text{mod}} = N_{\text{cells}}/4 = 200$ ps – possible assembling in JINR
4. Lead plates 80x80: $N_{\text{lead}} = N_{\text{sc}}/4 = 40000$ ps – will be stamped in Vladimir
 1. One Modules Lead Weight (200 pl *32 gr)=6.4.kg
 2. For 200 Modules – $6.4*200=1200$ kg of Lead
5. Lead: Exist 450 kg - 399960 Rub (889 Rub/kg – ordered already)

Matrix form for scintillator production (40x40x1.5 mm³)

Stamp for plate 80x80x0.5 mm³

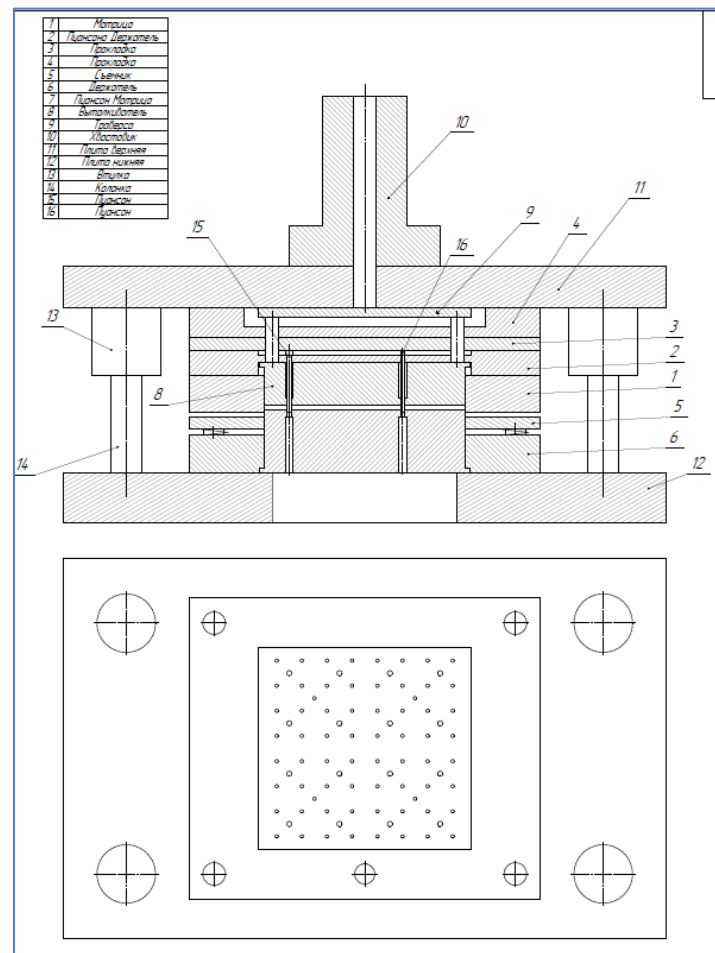
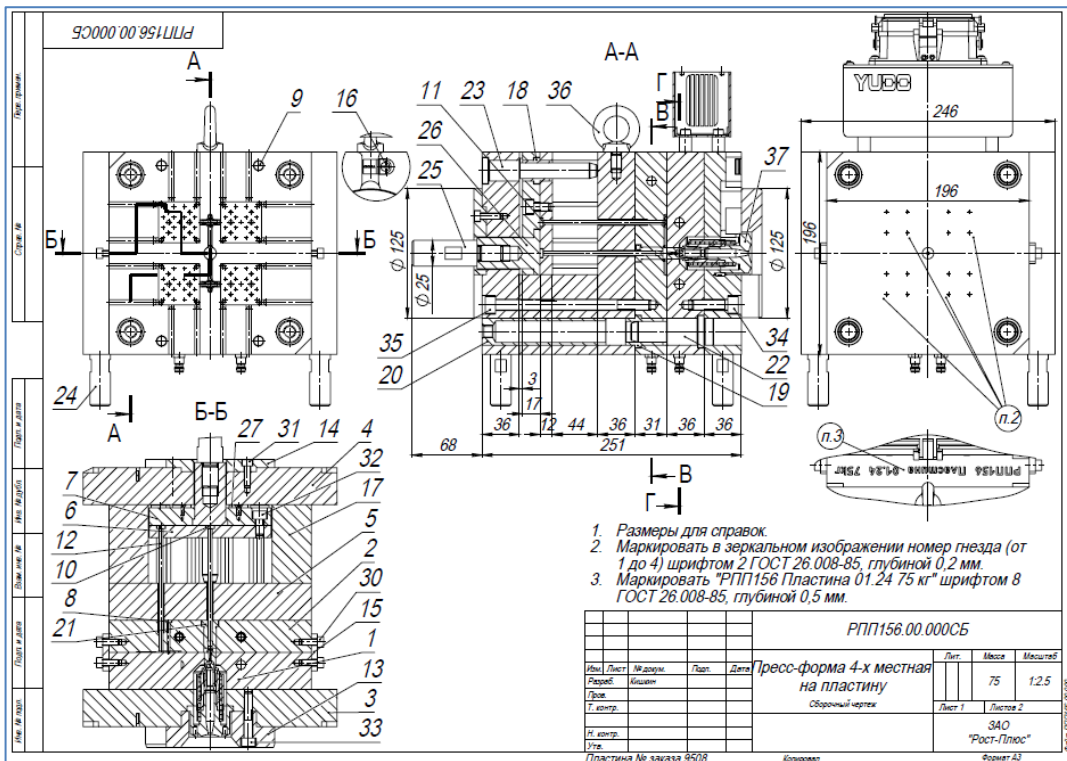

Matrix form for new scintillator production (40x40x1.5 mm³)

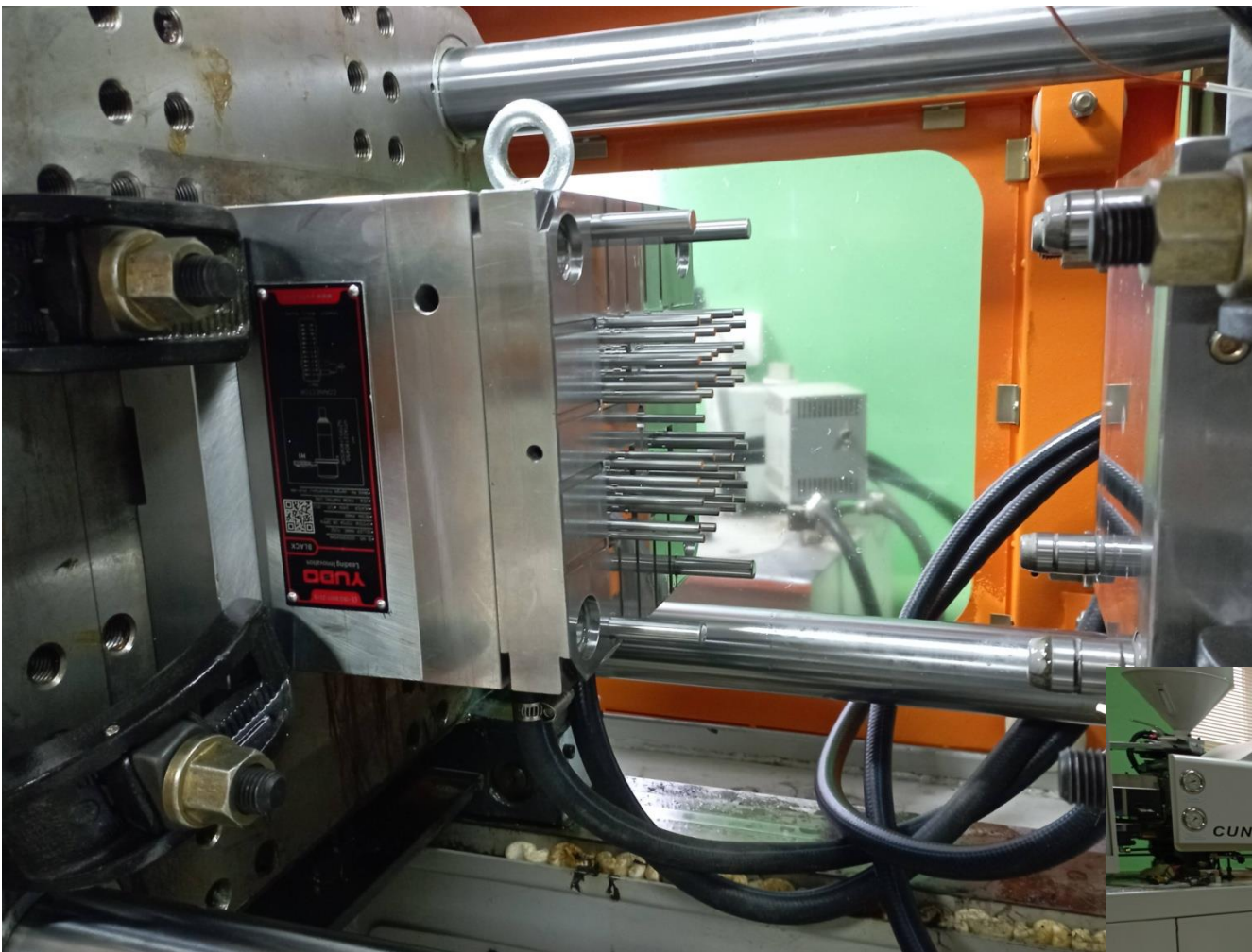

Injection molding machine with new Matrix form for Scintillator production

Quality test of scintillators.
Vladimir-UNIPLAST
February of 2024



New Cells 160000 produced I Vladimir at February 2024



4 scintillators plates
after injection
molding machine

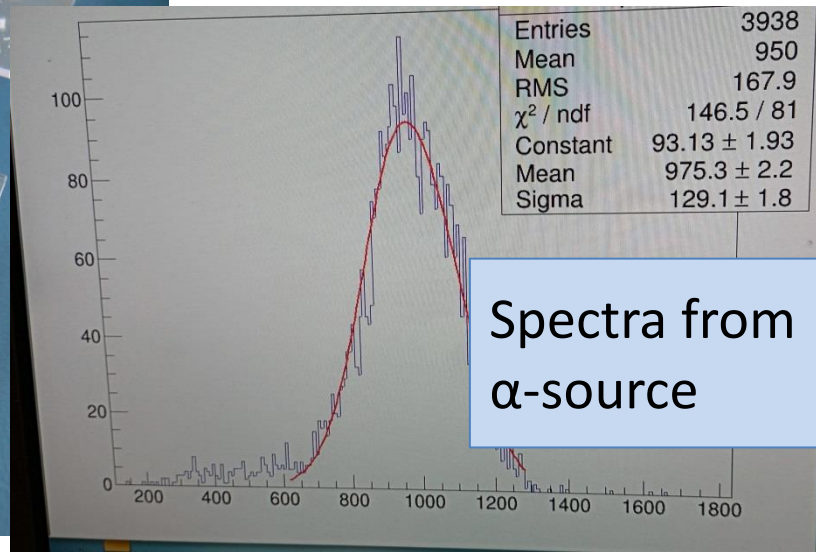

Spectra from
 α -source



Setup for
scintillators test

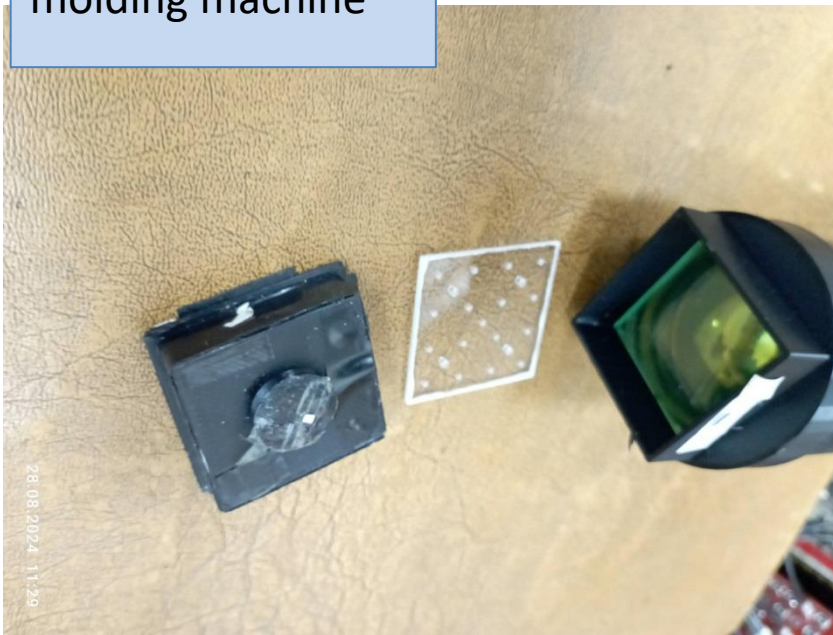

Scintillator plate:
 $40 \times 40 \text{ mm}^2$, $t=1.5 \text{ mm}$
WLS and PM

Scintillators painting



Scintillators painted and stored

Packaging of painted scintillator plates

Painting video file:
<https://photos.app.goo.gl/7yyTLzvsX6r7J8qF7>

09.09.2024 09:04

Drying of painted scintillator plates



26.08.2024 22:27

09.09.2024 09:04

Lead preparation

Lead cutting Setup



Drilling holes in a 80x80 mm² plate on a milling machine

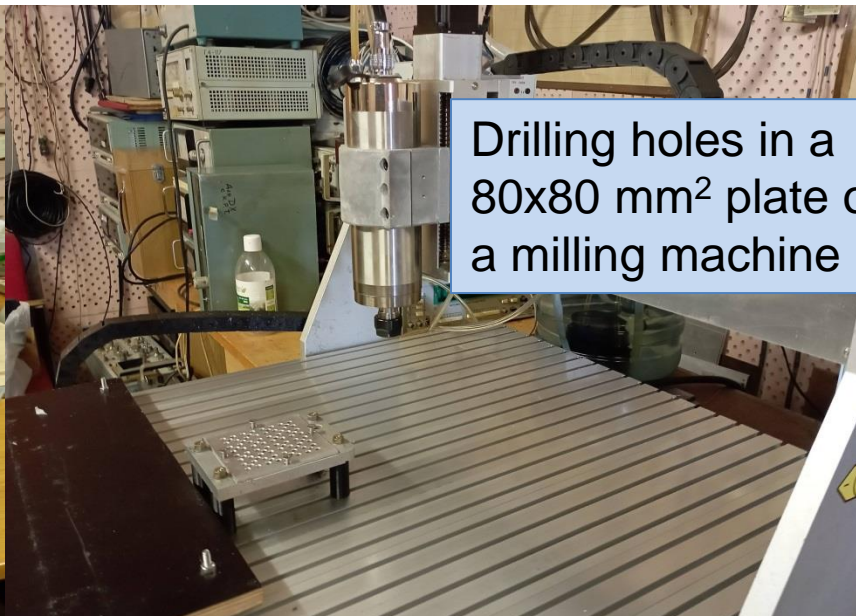

Washing of lead plates



Box for 200 plates of 85x168 mm² – it is blanks for the press
Has a weight ~20 kg



Module assembling – test setup

4-cells module assembling - in beginning starting



Final stage of module stacking with 200 layers of 1.5+0.5 mm scintillators And Led plates

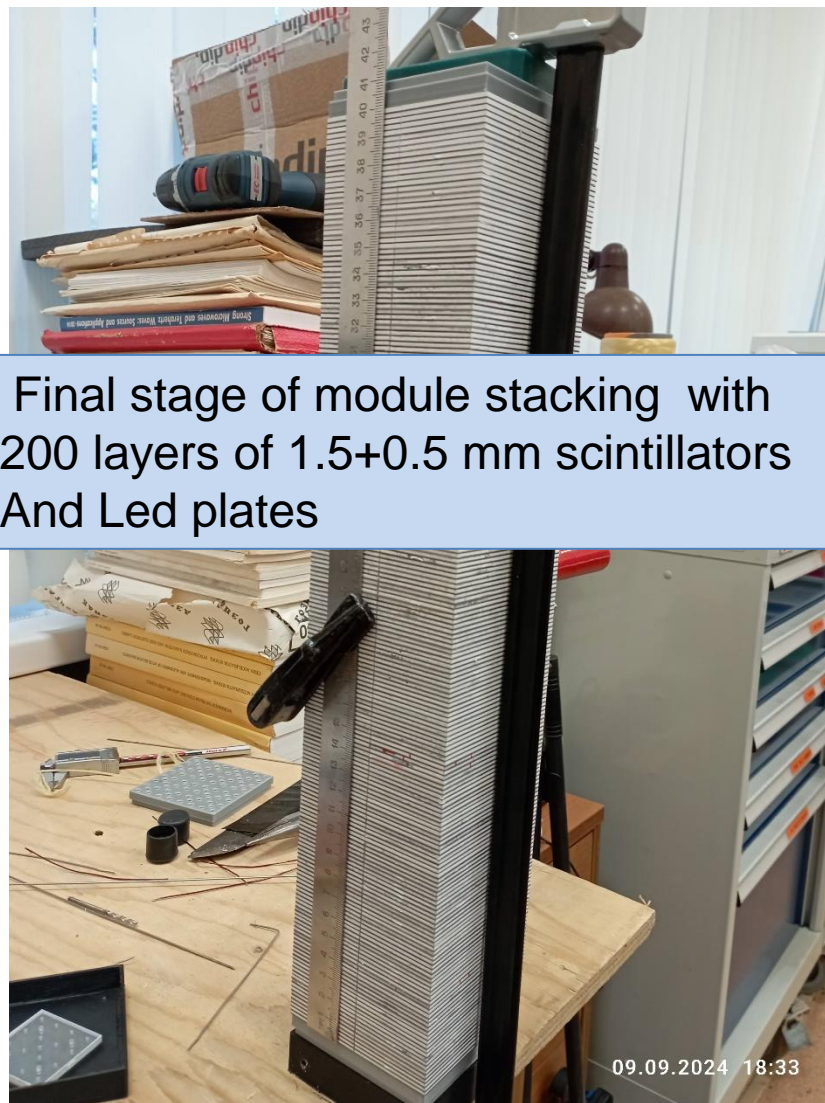

Module assembling and stress test setup

Stress test setup



4-cells module assembled and tied with a Kevlar rope



Center part Zoom



End Cup for SPD with new scintillator to be produced in 2024 via 256 cells of 40x40 mm²

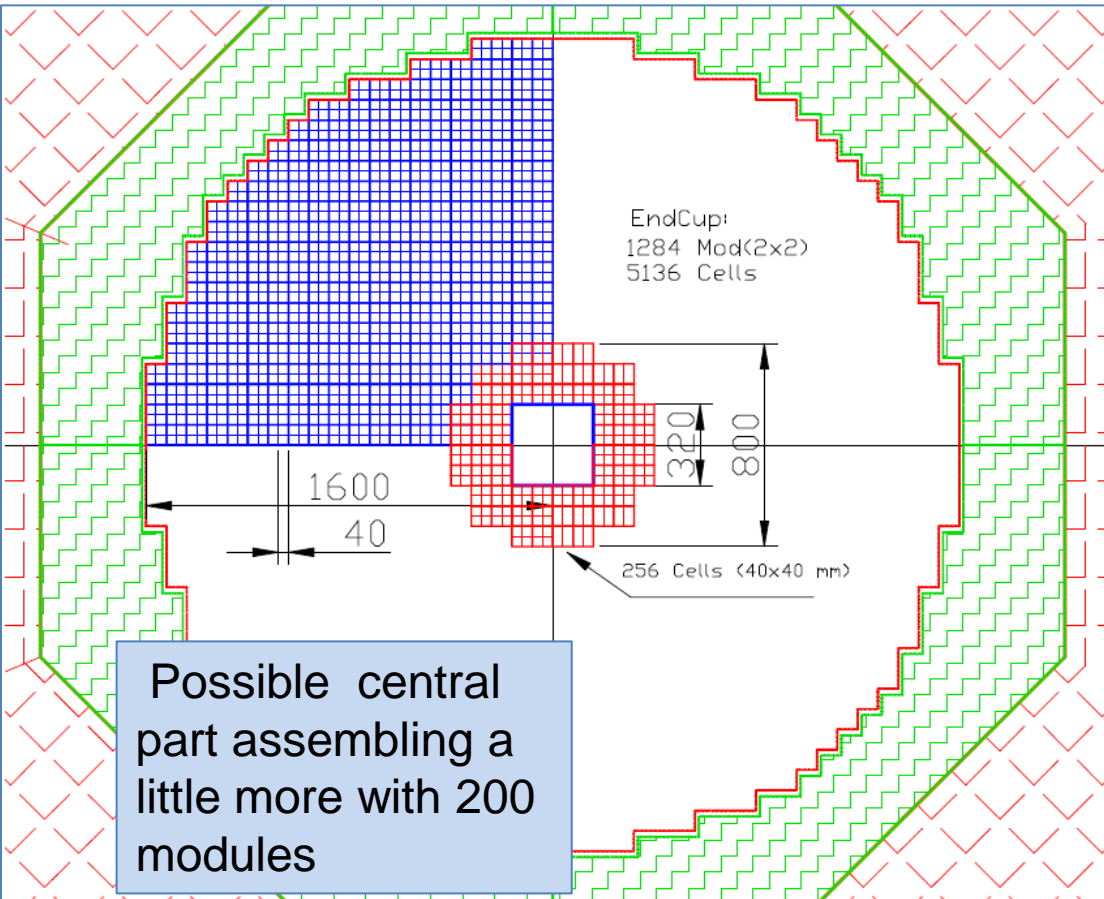

This Figure shows in red **64** modules, consisting of 4 cells each (**256 cells**). The weight of this assembly is 597 kg. This will require 130 kg of polystyrene, 465 kg of lead, as well as additives: 1.95 kg of P-terphenyl and 65 g. POPOP, and 2000 meters WLS fiber type Y-11.

To read this setup, we need **four ADC64 - 64-channel** amplitude encoders, as well as 16 boards of 16-channel amplifiers and bias voltage regulators.

ECAL setup in SPD

Phase_0

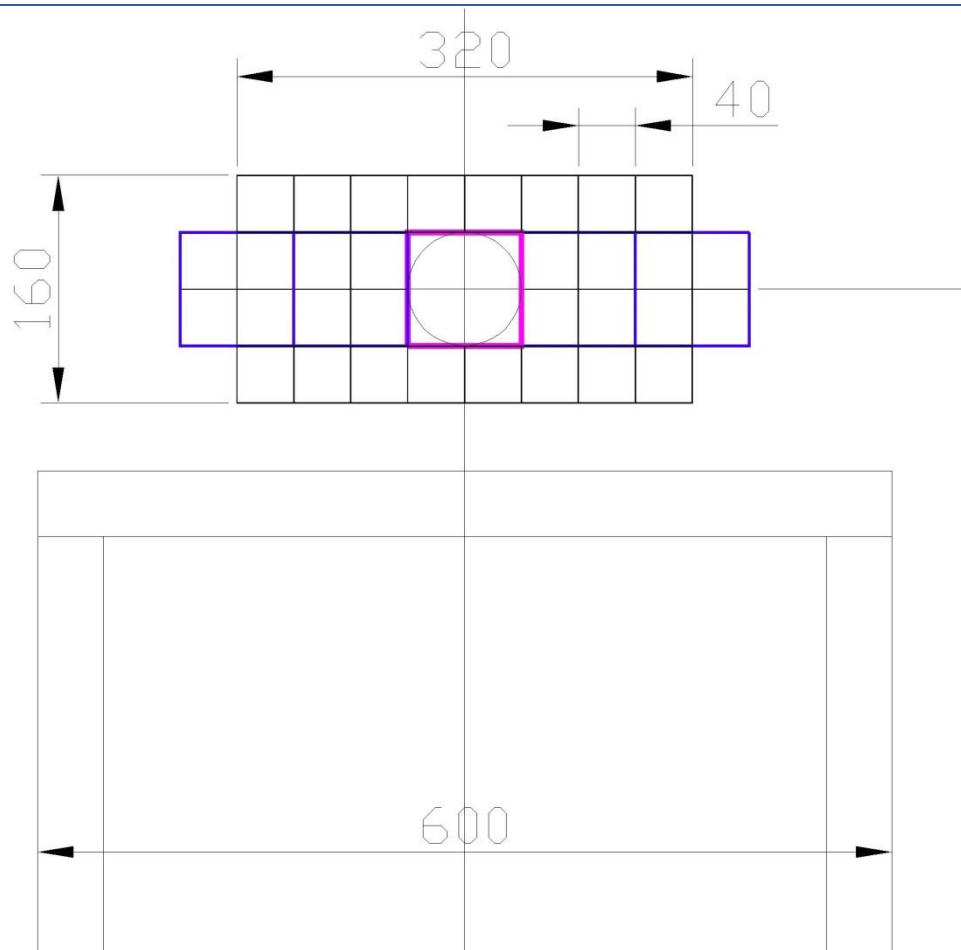

ECAL

ЕС - прототип в количестве 64-128 каналов (ячеек 40x40).

Нужно ~220 вольт 5 А для подключения:

1. Крейт NIM (САМАС)
2. ADC64 – 2 шт
2. Блоки питания SiPm
3. Ethernet - HUB для подключения и управления (1,2)
4. Место порядка 1 м³ (60x80 см².)

Possible central part assembling a little bit with 128 cells (32 modules)

ECAL plan up to 2024

Year: 20++	24	25	26	27	28	29	30	31	32	33	34
Task Name											
FRAME:											
Design Frame											
Frame production											
ELECTRONIC											
ADC R&D											
ADC Production											
ADC Cooling											
Slow Control											
FE R&D Production											
HARDWARE											
WLS purchase											
MPPC purchase											
Modules R&D											
Scintillator.Product.											
Lead Abs. Production											
Mod. Assembling											
Modules Testig											
ECAL installation											
Comissioning											

End of Report

Thanks for attention to *All*