

60th meeting of the PAC for Nuclear Physics
23-24 Jan 2025, JINR, Dubna



Study of chemical and physical properties of superheavy elements at the SHE Factory

Alexandr Svirikhin

Head of sector №2

Flerov Laboratory of Nuclear Reactions

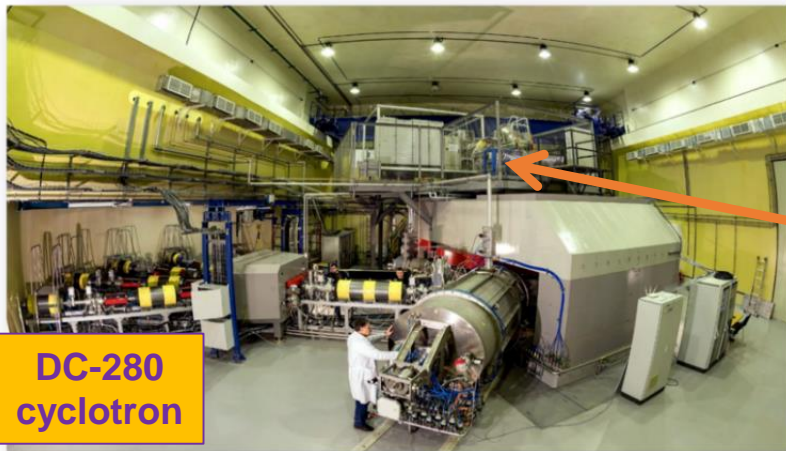

**DC-280
cyclotron**



**DECRIS-PM
ECR-ion source**

2024 beam program

Ion	Energy, MeV/nuclon	I (pμA)	I _{max} (pμA)	Setup
⁴⁰ Ar ⁸⁺	231	1,9	1,9	GRAND
⁴⁸ Ca ¹⁰⁺	225	2,0	2,0	GRAND
⁵⁴ Cr ¹⁰⁺	306	2,0		DGFRS-2
⁴⁸ Ca ¹⁰⁺	229	3,0	6,0	GRAND
⁵⁰ Ti ⁹⁺	230	1,7	2,0	DGFRS-2
⁵⁰ Ti ⁹⁺	280	1,7		DGFRS-2
⁴⁰ Ar ⁸⁺	232	2,5		GRAND
⁵⁰ Ti ⁹⁺	252	2,2	2,8	DC-280 group
⁵⁰ Ti ⁹⁺	229	1,0		DGFRS-2
⁵⁰ Ti ⁹⁺	275	1,7	1,9	DGFRS-2

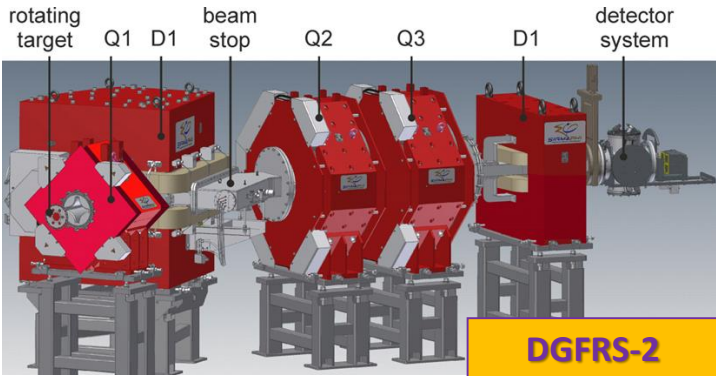

Experiment $^{238}\text{U} + ^{54}\text{Cr}$

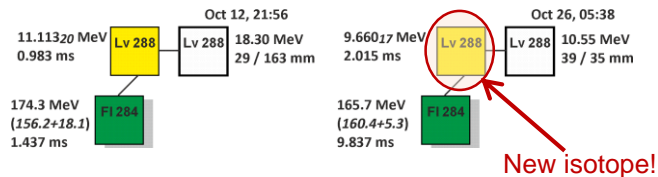

Target ^{238}U : 0.72 mg/cm²
 Dose: 7.2×10^{19}
 Excitation energy: 42 MeV
 Actinide + ^{54}Cr - first time!

Cross-section ~ 36 (12-82) fb

Experiment $^{242}\text{Pu} + ^{50}\text{Ti}$

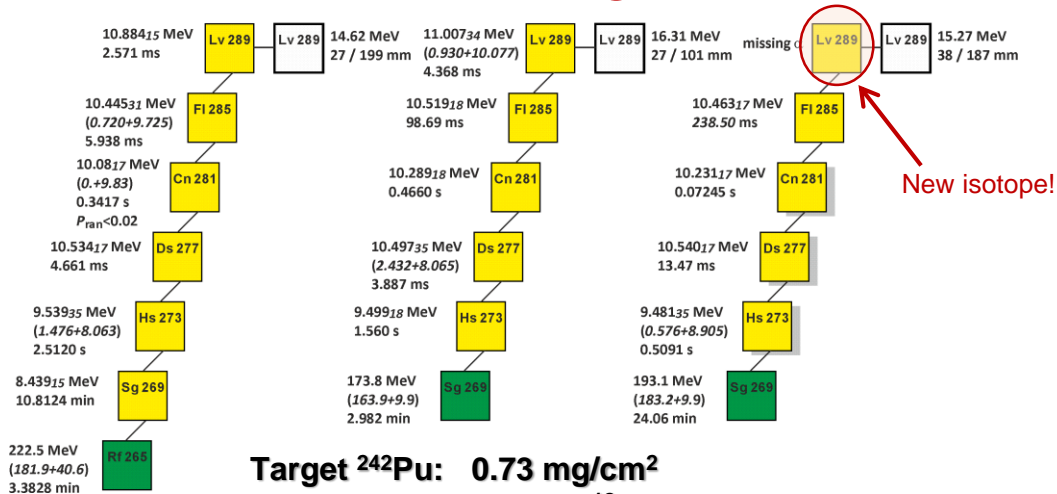
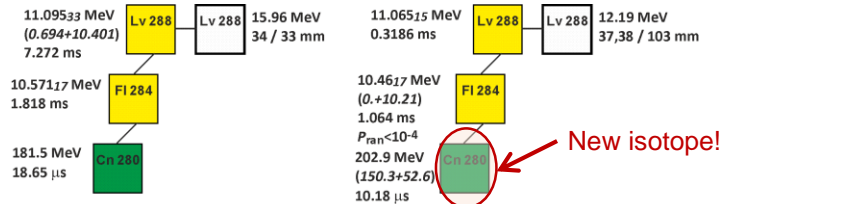

Target ^{242}Pu : 0.73 mg/cm²
 Beam dose: 1.5×10^{18}
 Excitation energy: 41 MeV
 a-decay of ^{284}Fl - first time!

Cross section: ~ 0.54 pb

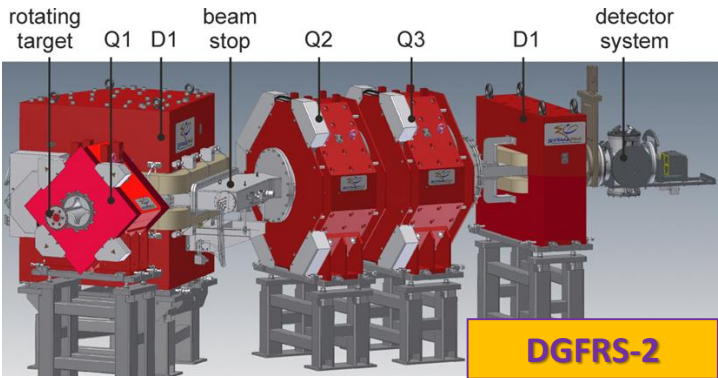

Next stage

Synthesis of new elements 119 and 120

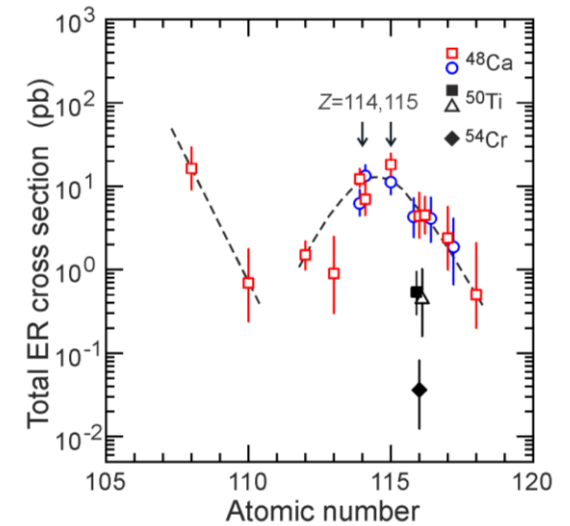

Proton number

Rg
Ds
Mt
Hs
Bh
Sg
Db
Rf

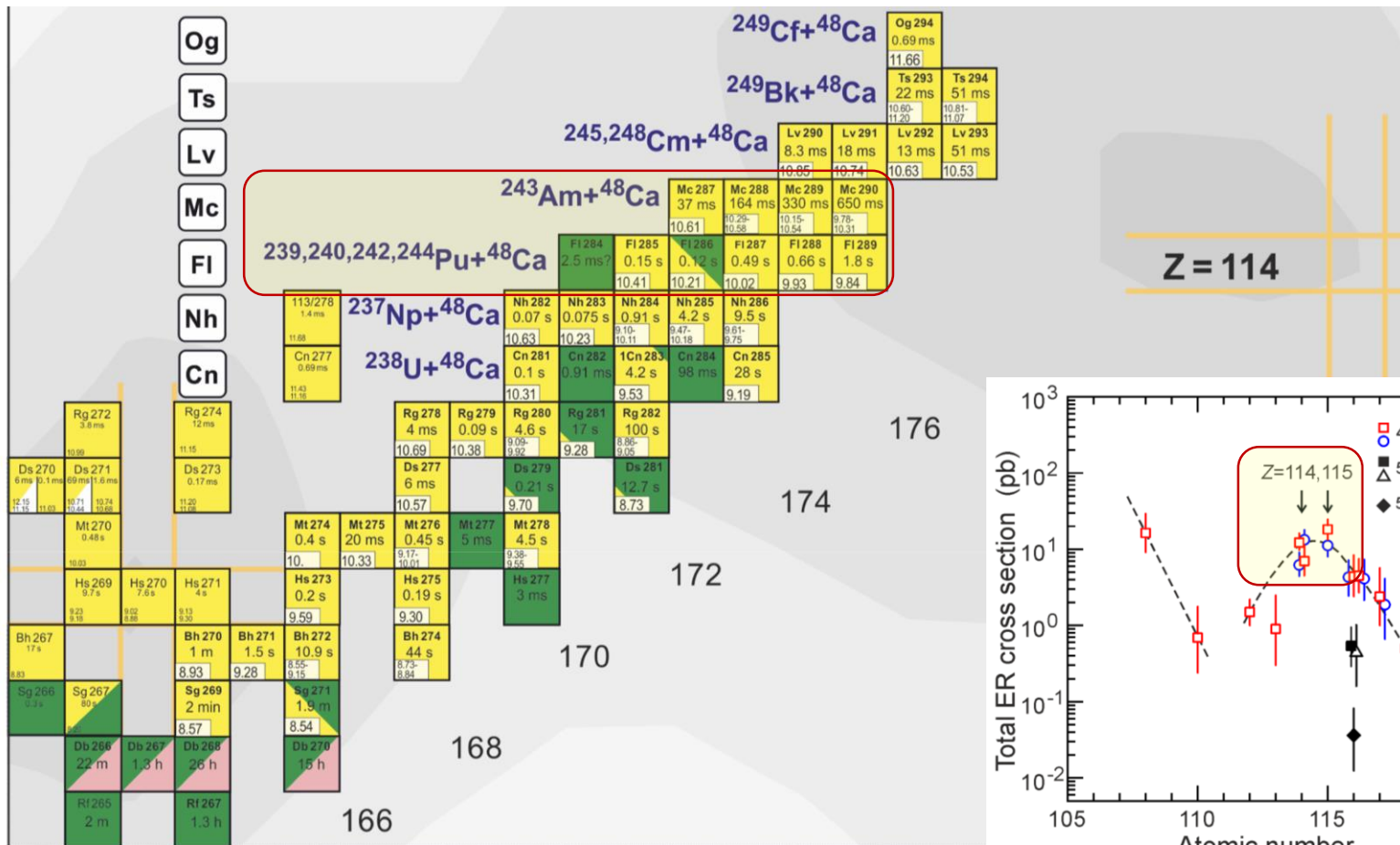

Z = 114

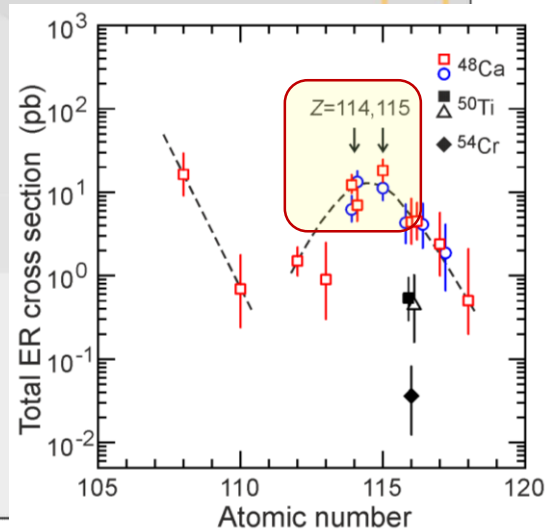

Neutron number

Separator **GRAND** Gas-filled **R**ecoil **A**nalyzer and **N**uclei **D**etector

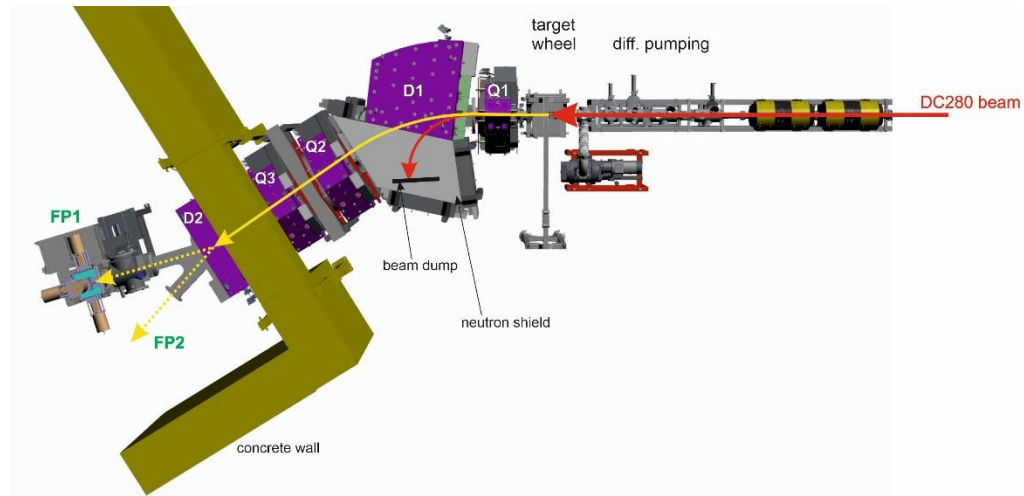

PEPAN Letters, 2024, Vol. 21, No. 3, pp. 518–525

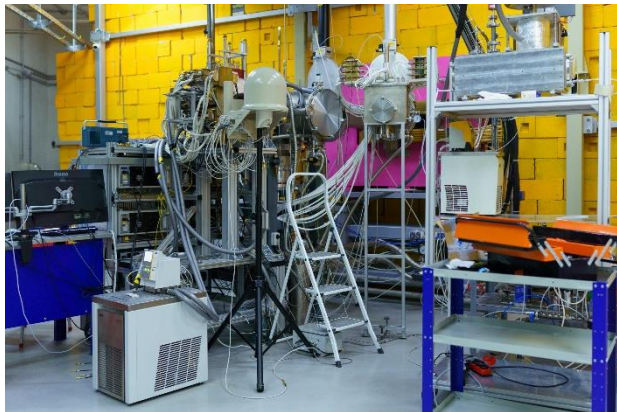

Separator **GRAND** Gas-filled **R**ecoil **A**nalyzer and **N**uclei **D**etector

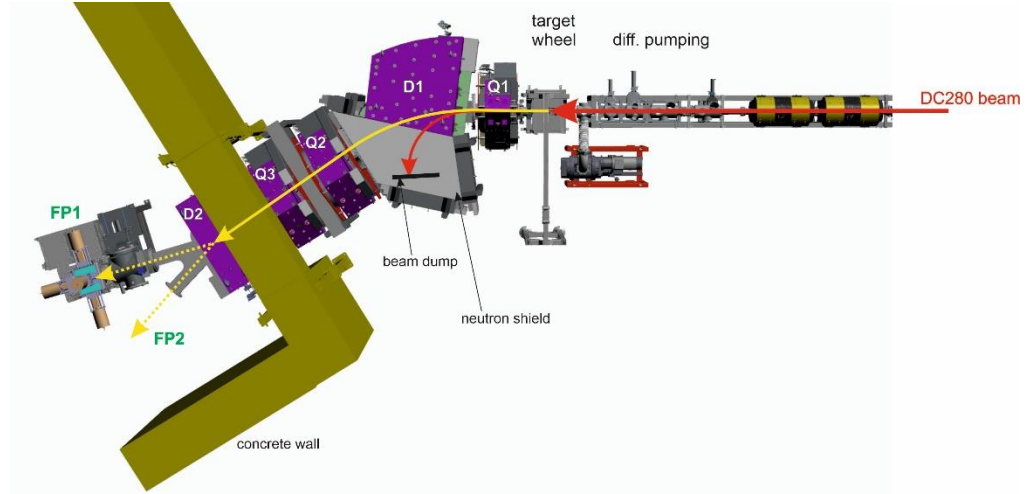

PEPAN Letters, 2024, Vol. 21, No. 3, pp. 518–525

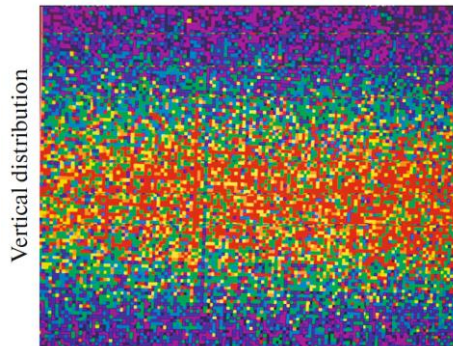

Table 1. Comparative parameters of gas-filled separators used in experiments on the synthesis and study of the properties of isotopes of heavy elements

Facility	Configuration	Acceptance angle, msr	Rotation angle	Max. Bp, T m	Dispersion mm/% Bp	Length, m	Ref.
DGFRS1	$D_h Q_h Q_v$	10	23°	3.1	7.5	4.07	[5]
DGFRS2	$Q_v D_h Q_h Q_v D$	16	$(32 + 10)^\circ$	3.35	32.8	7.41	[6]
BGS	$Q_v D_h D$	45	$(25 + 45)^\circ$	2.5	20.0	4.6	[7]
GARIS1	$D_{vh} Q_h Q_v D$	12.2	$(45 + 10)^\circ$	2.16	9.7	5.76	[8]
GARIS2	$Q_v D_h Q_h Q_v D$	18.5	$(30 + 7)^\circ$	2.43	19.3	5.06	[9]
TASCA	$D Q_h Q_v$	13.3	30°	2.4	9.0	3.5	[10]
RITU	$Q_v D Q_h Q_v$	8.5	25°	2.2	10.0	4.8	[11]
SHANS	$Q_v D Q_h Q_h$	25	52°	2.88	7.3	6.5	[12]
SHANS2	$Q_v D Q_h Q_v D$	25	$(30 + 10)^\circ$	2.56	20.9	5.97	[13]
AGFA	$Q_v D_h$	$44 - 22^a$	38°	2.5		$3.7 - 4.3^b$	[14]
GRAND	$Q_v D_h Q_h Q_h D$	16	$(32 \pm 15)^\circ$	3.35	32.8	$7.95^b; 6.84^c$	This work

^aDistance to target up to Q 40 cm or 84 cm, ^bdistance from the target to the "physical" focal detector, and ^cdistance from the target to the "chemical" stop chamber of RNs.

Tests of ion optics
 $^{48}\text{Ca} + ^{170}\text{Er} \rightarrow 4n + ^{214}\text{Ra}$
 FP1 – 100x100 cm² DSSD



Horizontal distribution

Q_v D₃₀ Q_h Q_v D₁₅

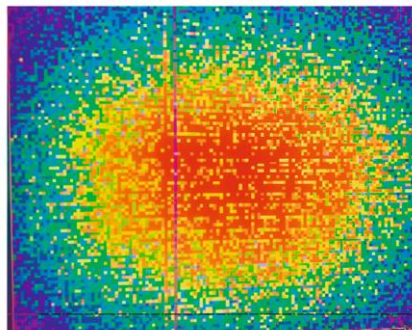

Horizontal distribution

Q_v D₃₀ Q_v Q_h D₁₅

Separator GRAND Gas-filled Recoil Analyzer and Nuclei Detector

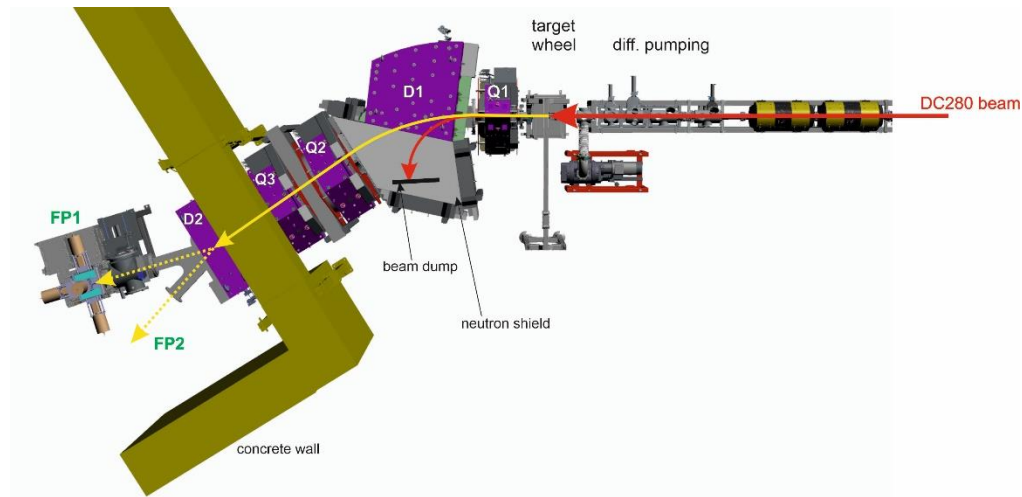

PEPAN Letters, 2024, Vol. 21, No. 3, pp. 518–525

Table 1. Comparative parameters of gas-filled separators used in experiments on the synthesis and study of the properties of isotopes of heavy elements

Facility	Configuration	Acceptance angle, msr	Rotation angle	Max. Bp, T m	Dispersion mm/% Bp	Length, m	Ref.
DGFRS1	D _v Q _h Q _v	10	23°	3.1	7.5	4.07	[5]
DGFRS2	Q _v D _h Q _h Q _v D	16	(32 + 10)°	3.35	32.8	7.41	[6]
BGS	Q _v D _h D	45	(25 + 45)°	2.5	20.0	4.6	[7]
GARIS1	D _{vh} Q _h Q _v D	12.2	(45 + 10)°	2.16	9.7	5.76	[8]
GARIS2	Q _v D _h Q _h Q _v D	18.5	(30 + 7)°	2.43	19.3	5.06	[9]
TASCA	DQ _h Q _v	13.3	30°	2.4	9.0	3.5	[10]
RITU	Q _v DQ _h Q _v	8.5	25°	2.2	10.0	4.8	[11]
SHANS	Q _v DQ _v Q _h	25	52°	2.88	7.3	6.5	[12]
SHANS2	Q _v DQ _h Q _v D	25	(30 + 10)°	2.56	20.9	5.97	[13]
AGFA	Q _v D _h	44	38°	2.5	3.7	4.3 ^a	[14]
GRAND	Q _v D _h Q _v Q _h D	16	(32 ± 15)°	3.35	32.8	7.95 ^b ; 6.84 ^c	This work

^aDistance to target up to Q 40 cm or 84 cm, ^bdistance from the target to the “physical” focal detector, and ^cdistance from the target to the “chemical” stop chamber of RNs.

GABRIELA

*Gamma Alpha Beta Recoil Investigation with the
Electromagnetic Analyser*

Si-detector (DSSSD)

- 100x100mm² or 128x128 strips
- 16384 pixels;
- Thickness: 500 μm

Tunnel Si-detectors (DSSSD)

- 50x60mm², 8 x 16x32 strips;
- Thickness: 700 μm

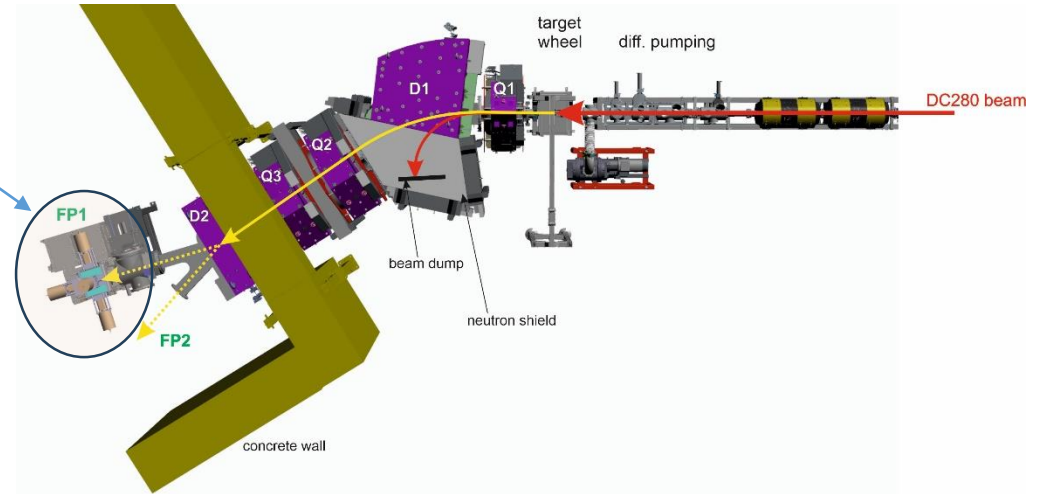

5 Ge-detectors

- Clover-type, HPGe,
- 100x100 mm, 70 mm height)
- BGO-shields

TOF system

- 1 e-emitting foil
- 2MCP-based e-detectors (70x90 mm²)

GABRIELA

*Gamma Alpha Beta Recoil Investigation with the
Electromagnetic Analyser*

Si-detector (DSSSD)

- 100x100mm² or 128x128 strips
- 16384 pixels;
- Thickness: 500 μ m

Tunnel Si-detectors (DSSSD)

- 50x60mm², 8 x 16x32 strips;
- Thickness: 700 μ m

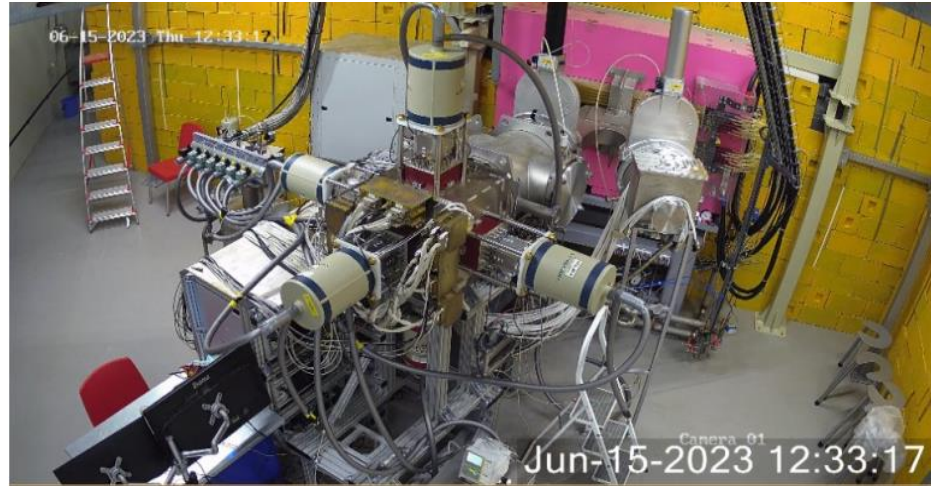

5 Ge-detectors

- Clover-type, HPGe,
- 100x100 mm, 70 mm height)
- BGO-shields

TOF system

- 1 e-emitting foil
- 2MCP-based e-detectors (70x90 mm²)

GABRIELA

*Gamma Alpha Beta Recoil Investigation with the
Electromagnetic Analyser*

	FWHM, keV	Thresholds, keV
Focal plane 100x100mm ²	10.8±0.6 keV - 320 keV electrons; 16.5±0.8 keV - 7.92 MeV alphas	40-60
<u>Tunnel Si-</u> <u>detectors</u>	14.4±1.2 keV - 320 keV electrons 120±11 keV - 7.92 MeV alphas	60-100

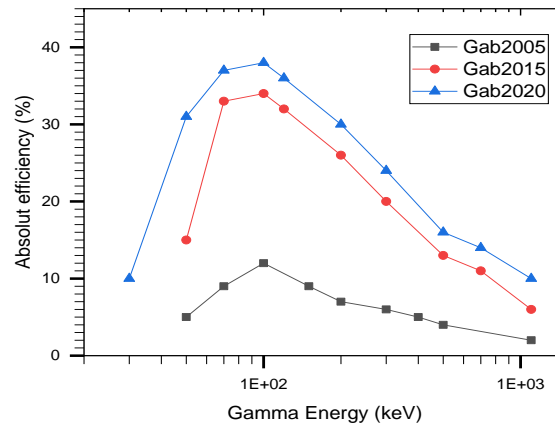
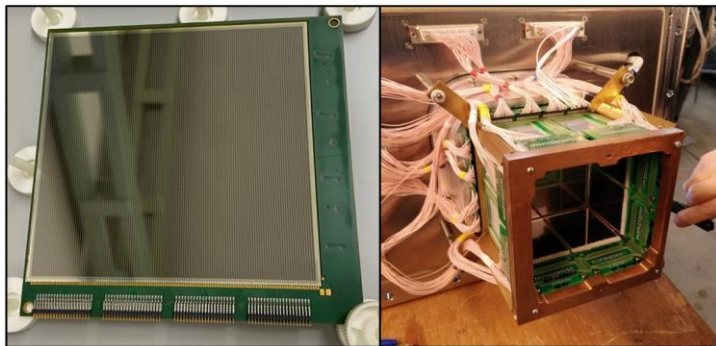

December 2022 - test experiment GRAND + GABRIELA focal plane (no HPGe)
 + COLD detector at FP2 (preparation for the SHE chemistry)



$E_{\text{lab}}, \text{MeV}$	$E_{1/2}, \text{MeV}$	E^*, MeV	$N(3n) - ^{287}\text{Fl}$	$N(4n) - ^{286}\text{Fl}$	Integral flux	$\sigma(3n), \text{pbarn}$	$\sigma(4n), \text{pbarn}$
252	240.4	38.4	9	2	$4.82 \cdot 10^{18}$	$8.5^{+3.6}_{-2.7}$	$0.85^{+1.0}_{-0.6}$
256	243	40.6	3	2	$2.35 \cdot 10^{18}$	$5.2^{+4.8}_{-3.0}$	$1.7^{+2.1}_{-1.2}$

Target ^{242}Pu – 240 mm, 0.7 mg/cm².

Mean beam intensity – 2 μA .

→ 2 - 3 events / day !

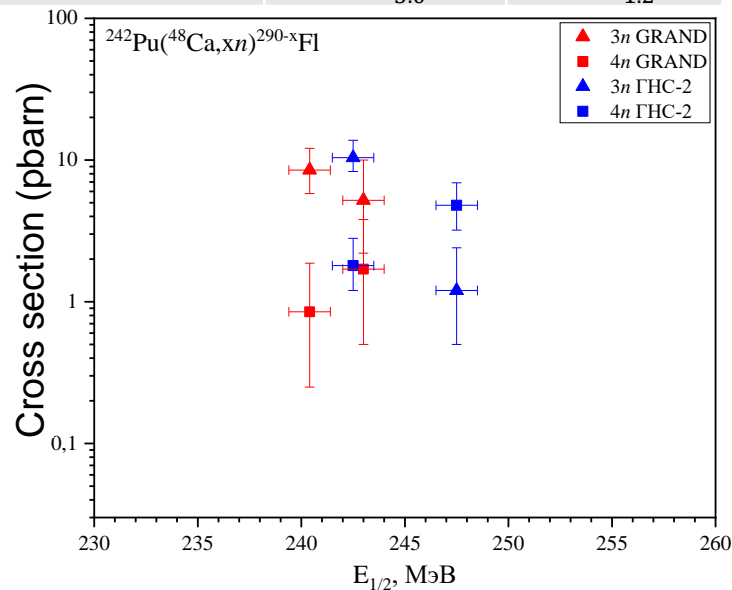

June 2023 – GRAND + GABRIELA

Reactions	CN	3n	4n	5n
(1) ²⁶ Mg+ ²⁰⁸ Pb	²³⁴ Pu	129.8 nb*	21.5 nb*	2.48 nb* _
(2) ²⁶ Mg+ ²⁰⁶ Pb	²³² Pu	0.35 nb	0.15 nb	0.11 nb
(3) ²⁶ Mg+ ²⁰⁴ Pb	²³⁰ Pu	0.15 nb	0.02 nb	

Isotopes	Experiment		Literature's data		Decay mode
	E _α keV	T _{1/2}	E _α keV	T _{1/2}	
²³⁰ Pu _{gamma}	6990±16	-	6999	102 s	α ~100%
	7057±11		7057		
²²⁹ Pu	7459±10	-	7460	90 s	α ~50% EC~50%
²²⁸ Pu	<u>7762±37</u>	<u>0.253 s</u>	7810/7772	1.1/0.3 s	α ~100%
Theory					
²²⁷ Pu _{new!}	8156±26 (b _{EC} = 0,23 ± 0,10)	2.2 s	8153	0,86 s	α ~69% EC ~ 31%
²²⁶ Pu _{new!}	8754±24	≥ 1 ms (1 event!)	8773	1 ms	α ~100%

- **TAN** conference (Nov-2023, Huizhou, China)
- **JINR Preprint**, P7-2024-50
- *To be published in PEPAN Letters*, V22, 2025

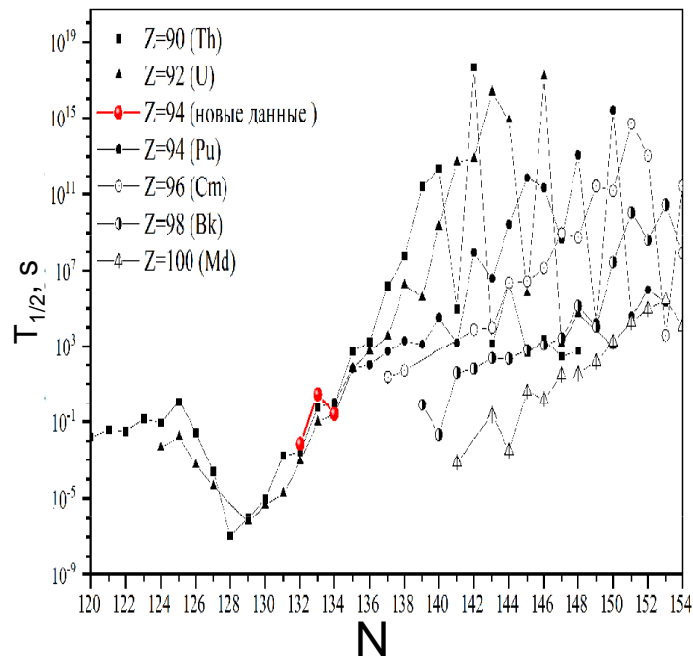

December 2023 – GRAND + GABRIELA

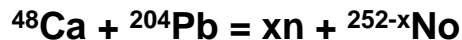

Experimental setup	SHELS @U400	GRAND @DC280
Year of experiment	2020	2023
Duration of irradiation	19 days	13 days
Beam intensity	~0.5 μA	3 μA
Beam dose	$4 \cdot 10^{18}$	$21 \cdot 10^{18}$
Number of beam energy values	4	7
Number of ${}^{249}\text{No}$ (ER- α)	200 nuclei	400 nuclei

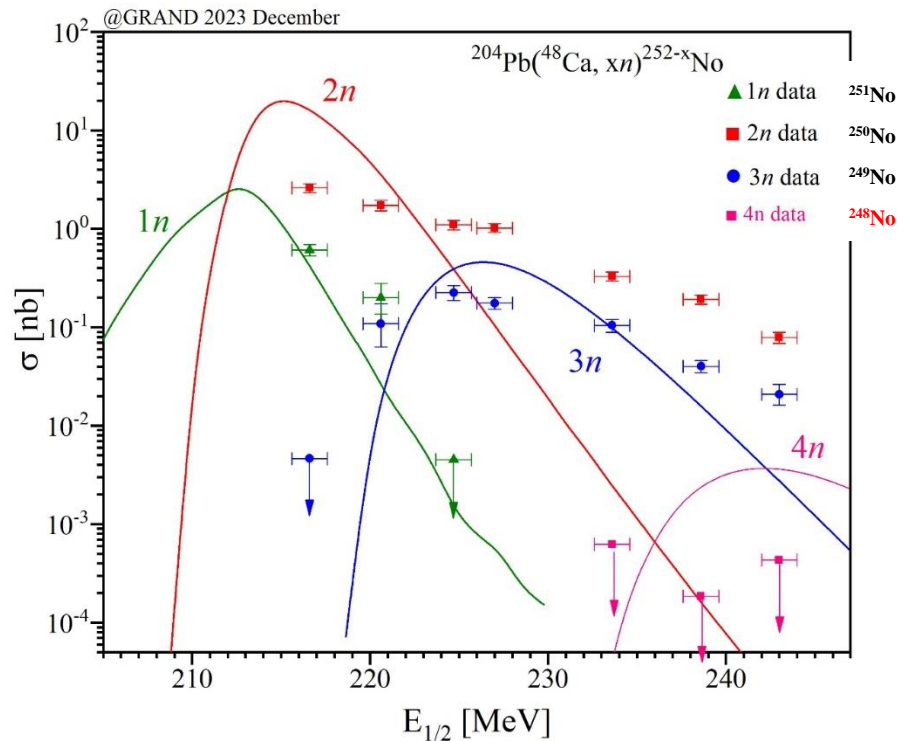

A.I.Svirikhin et. al., **The New ${}^{249}\text{No}$ Isotope**, *PEPAN Letters*, 2021, Vol. 18, No. 4,

M. Tezekbayeva et al., *Eur. Phys. J. A.* 58:52 (2022)

A. Lopez-Martens et al., *Phys. Rev. C.* 2022. Vol. 105, № 2.

Target wheels with 240 and 480 mm diameter

April 2024 – GRAND + GABRIELA



- Target: 690 $\mu\text{g}/\text{sm}^2$ PbS (480 mm in diam. wheel)
- Beam: 4-6 μA of ^{48}Ca
- Result: 1-1.5 fissions/s from SF of ^{252}No implanted to the GRAND focal DSSSD.



GRAND 2024 ~85k SF of ^{252}No

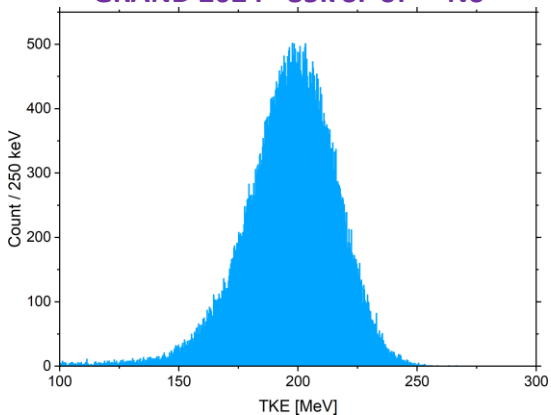

Bemis 1977, 176 SF

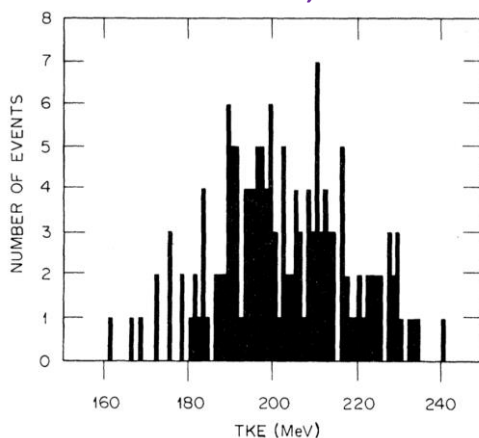

480 mm target wheel assembly design

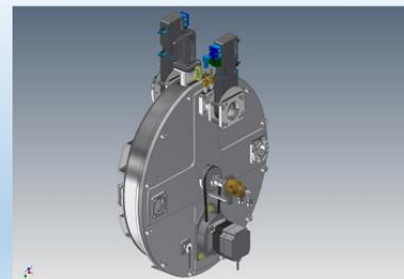

Chemistry of flerovium and copernicium

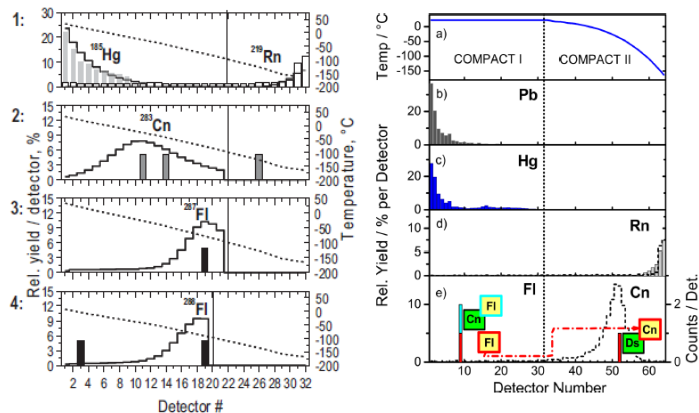

R. Eichler *et al.*,
Radiochim. Acta **98**, 133 (2010)

A. Yakushev *et al.*,
Inorg. Chem. **53**, 1624 (2014)

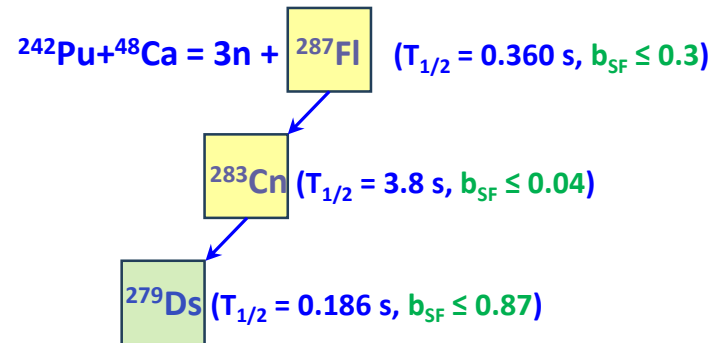

From the distributions of atoms over the detectors:

1. adsorption properties of Cn and Fl
2. thermodynamic characteristics of Cn and Fl compared with their light homologues Hg and Pb
3. experimental determination of the influence of relativistic effects on the chemical properties of the heaviest elements.
4. degree of compliance of the chemical behavior of the SHE with the law of periodicity of properties

Is flerovium a metal or a noble-gas-like?

Chemistry of flerovium and copernicium

gas adsorption thermochromatography method

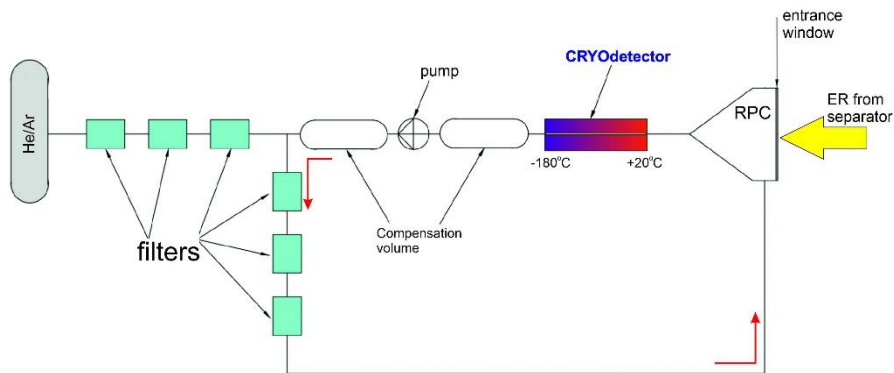

December 2022 run

GRAND – pre-separator before a chemical setup

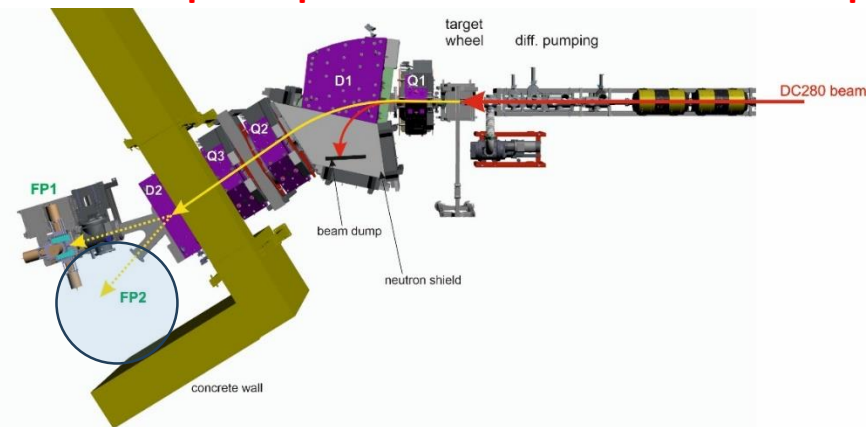

Target ^{242}Pu – 240 mm, 0.7 mg/cm².

Mean beam intensity – 2 pμA.

→ 2 - 3 events / day (at FP1)

→ **2 SF events / 1 month (at FP2)**

Chemistry of flerovium and copernicium

$^{208}\text{Pb}(^{48}\text{Ca}, 2n)^{254}\text{No}$ ($E_{\text{ER}} \approx 40 \text{ MeV}$)
 $^{144}\text{Sm}(^{40}\text{Ar}, xn)^{184-n}\text{Hg}$ ($E_{\text{ER}} \approx 47 \text{ MeV}$)

gas adsorption thermochromatography method

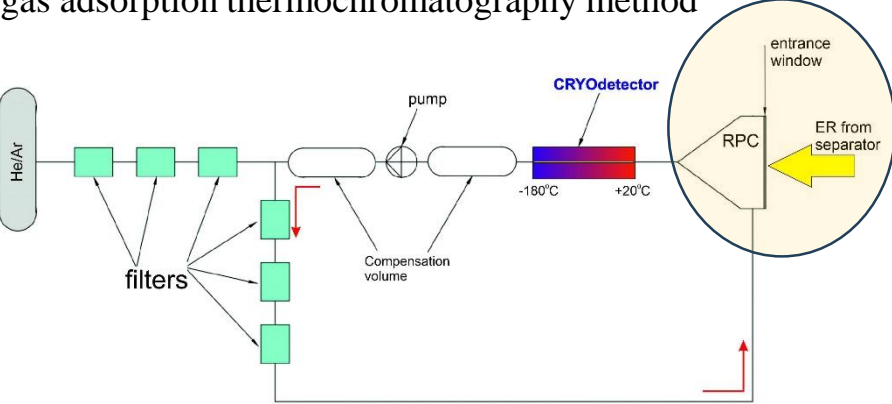

- Separating foil thickness optimization
- Grid geometry optimization
- Optimal gas pressure
- Optimal Ar/He proportion

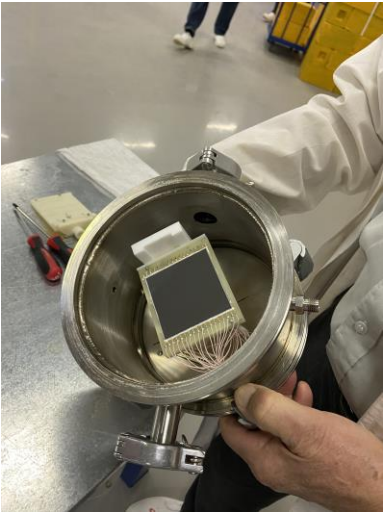
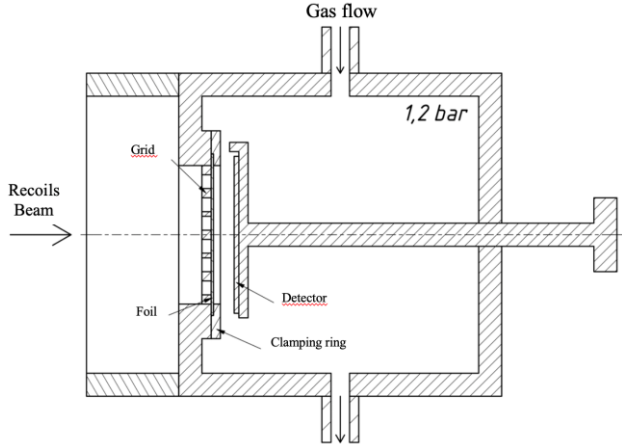
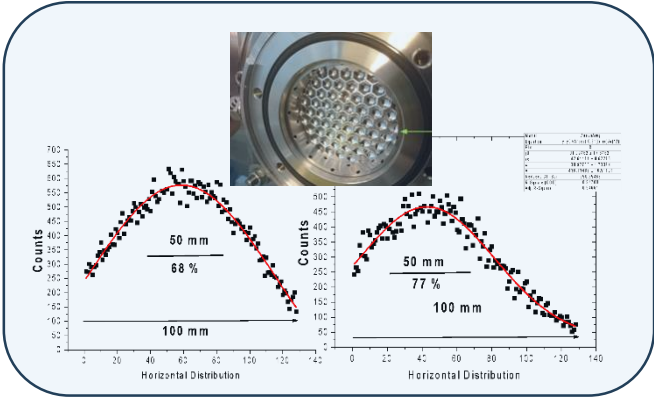

Chemistry of flerovium and copernicium

gas adsorption thermochromatography method

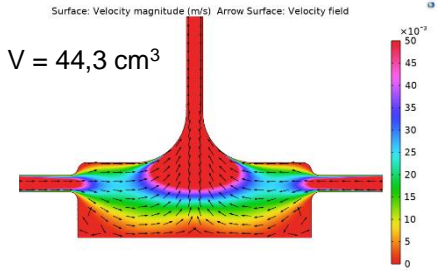
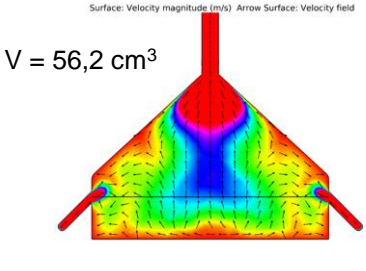
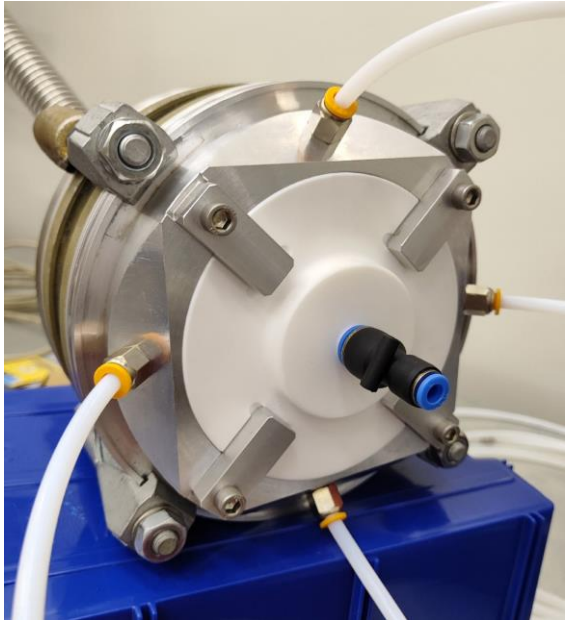
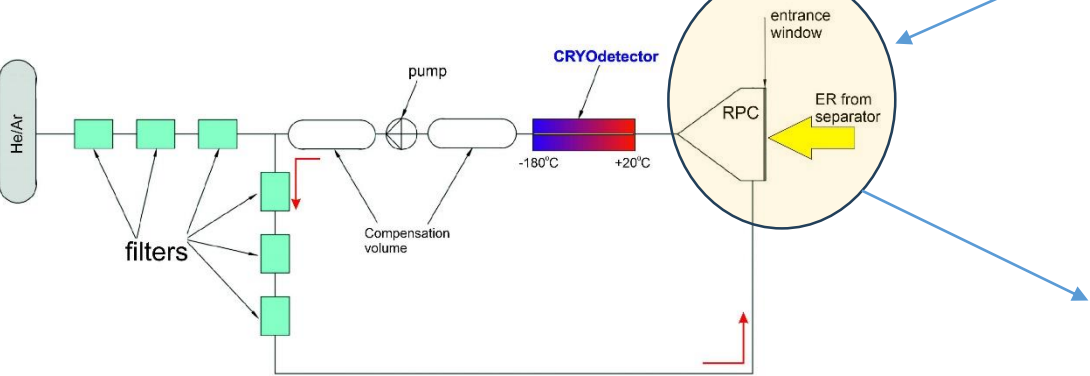
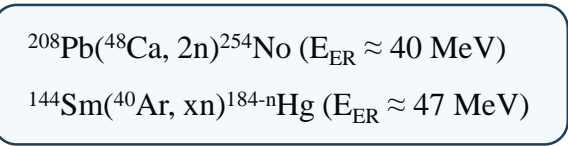

total gas renewal time = 1.6 s
 Hg transport time = 0.2 s!
 ^{287}Fl $T_{1/2} = 0.36 \text{ s}$

Chemistry of flerovium and copernicium

gas adsorption thermochromatography method

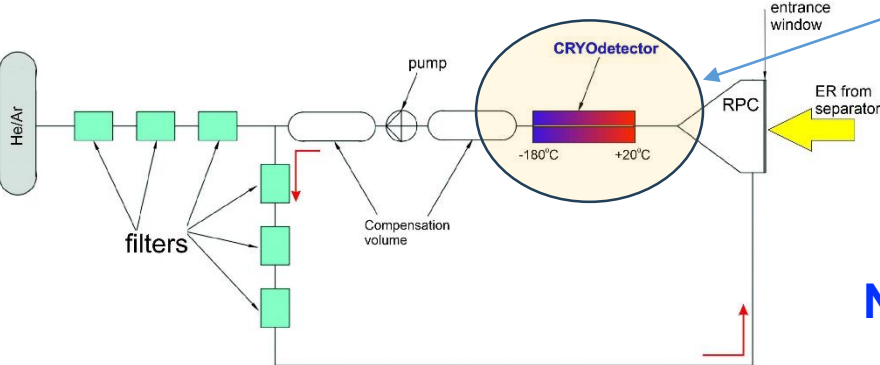
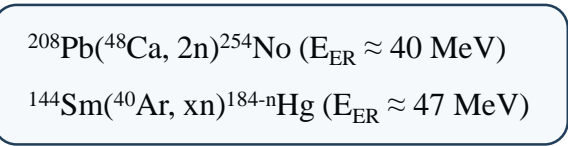

New detection modules with gold surface



$S_{\text{Si}} = 20 \times 10 \text{ mm}^2$
 $S_{\text{gold}} \approx 95\%$

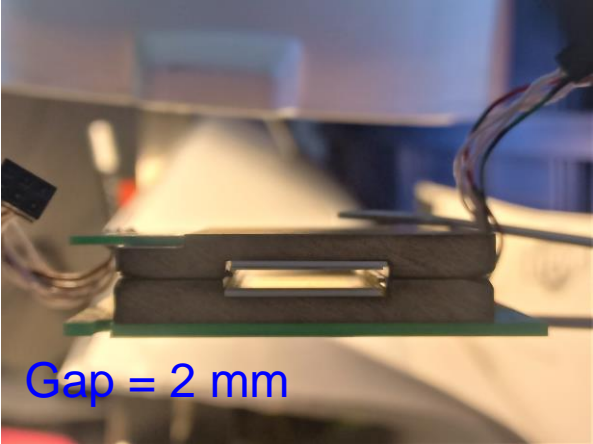
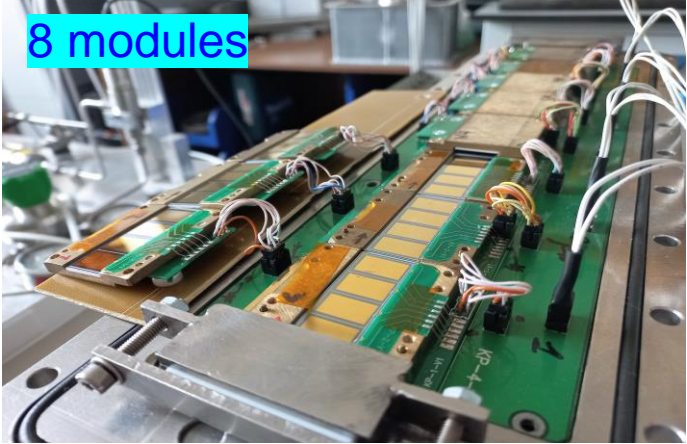

Chemistry of flerovium and copernicium

gas adsorption thermochromatography method

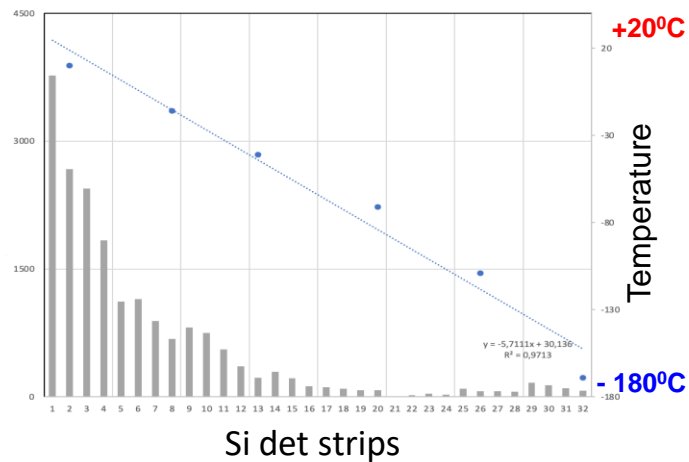
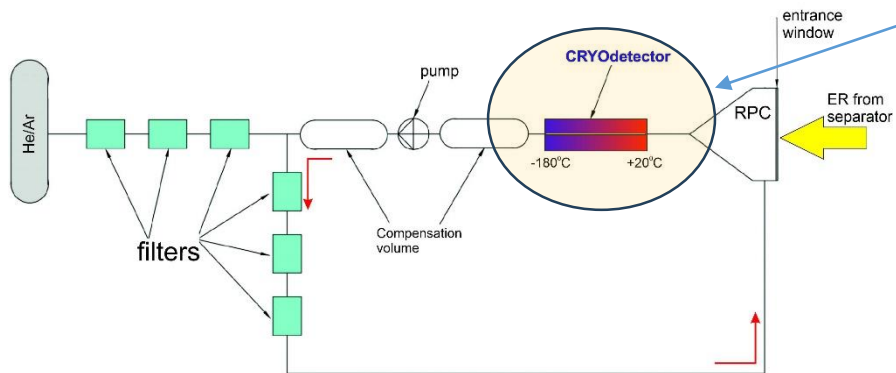
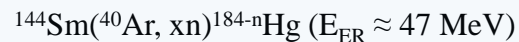

New LN cooling system



Chemistry of flerovium and copernicium

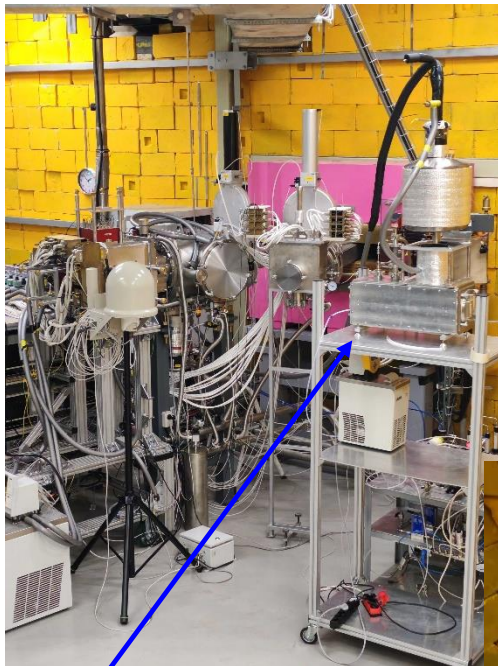

CRYOdetector

Gas transport

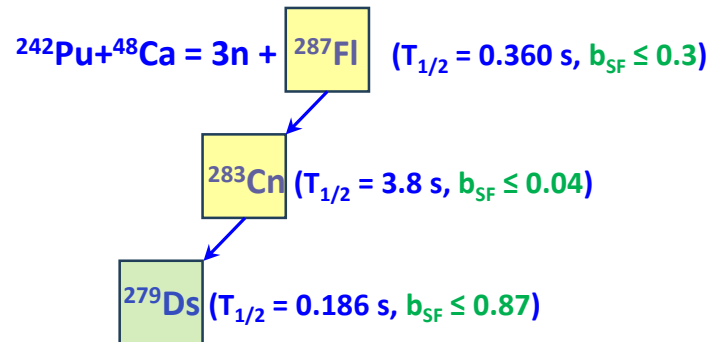
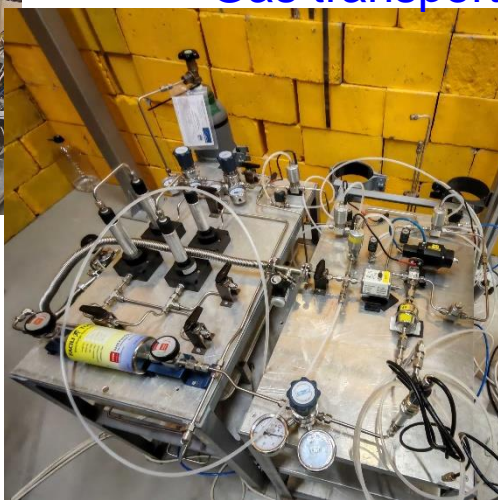

Cross section ≈ 10 pb (3n)

$\sigma = 10$ pb, $h_t = 0.7$ mg/cm², $\varnothing_t = 480$ mm,

$\epsilon_{\text{GRAND}} = 0.6$, $I_{\text{beam}} = 4\text{-}5$ pA $\rightarrow \approx 4\text{-}6$ Fl(Cn)/day $\times \epsilon_{\text{CRYO}}$

Chemistry of flerovium and copernicium

COLD-2007
After target!

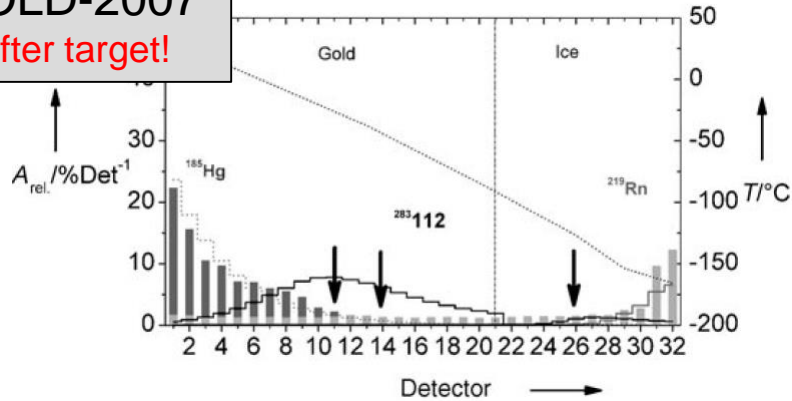

R. Eichler et.al, *Angew. Chem. Int. Ed.* 2008, 47, 3262

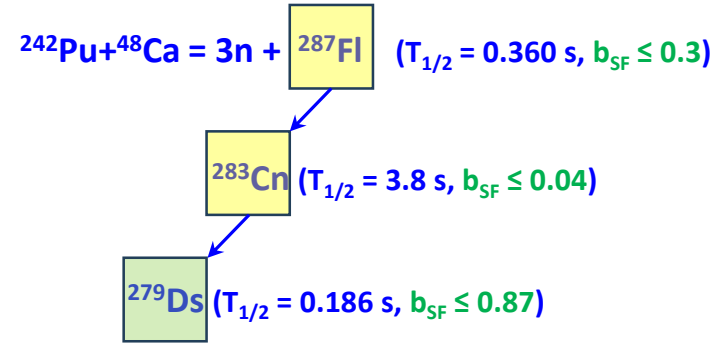

Cross section $\approx 10 \text{ pb}$ (3n)

$\sigma = 10 \text{ pb}$, $h_t = 0.7 \text{ mg/cm}^2$, $\varnothing_t = 480 \text{ mm}$,

$\epsilon_{\text{GRAND}} = 0.6$, $I_{\text{beam}} = 4\text{-}5 \text{ pA} \rightarrow \approx 4\text{-}6 \text{ Fl(Cn)/day} \times \epsilon_{\text{CRYO}}$

3 events of ${}^{283}\text{Cn} \rightarrow 3.1 \times 10^{18}$ ${}^{48}\text{Ca}$ ions from U400 cyclotron **(16 days!)**

??? events of ${}^{283}\text{Cn} \rightarrow 2.5 \times 10^{18}$ ${}^{48}\text{Ca}$ ions from DC280 cyclotron **(1 day!)**

Spectroscopy of SHE at GRAND

B. Sulignano *thesis PhD (Mainz, 2007)*

- **Location of closed shells:**
- Proton shell:
- 114, 120 or 126 / 114 – 126 ?
- Neutron shell:
- 172 or 184 ?

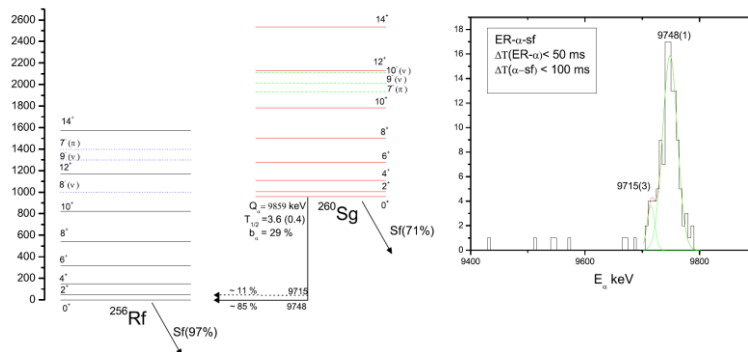

Experimental insight into the structure of Super Heavy Nuclei can be obtained by direct measurements of the **ground states properties** of nuclei.

- **Nuclear structure:**
- Lifetimes
- Decay modes
- Isomers

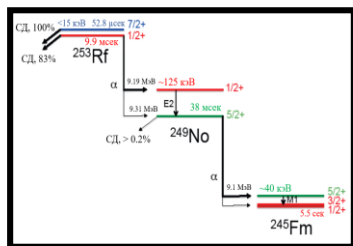

M. Tezekbayeva et al., *Eur. Phys. J. A.* 58:52 (2022)

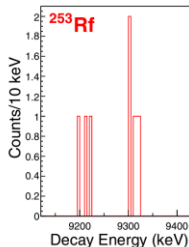

A. Lopez-Martens et al., *Phys. Rev. C.* 2022. Vol. 105, № 2. P. 50–53.

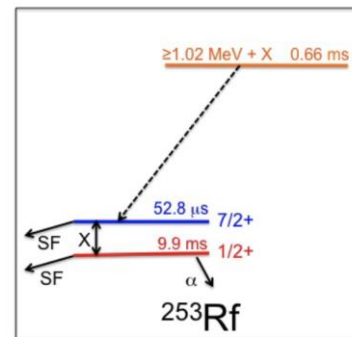
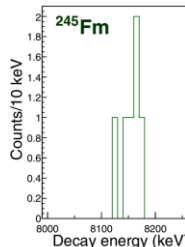
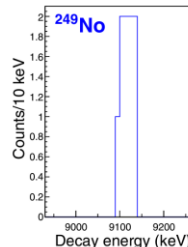

Spectroscopy of SHE at GRAND

Main goal of our activity in Spectroscopy of heavy nuclei :

1. Spectroscopy experiments using high resolution alpha, CE spectroscopy and Ge arrays to study Decays of No, Lr, Rf, Db and Sg isotopes and daughter nuclei.

GABRIELA-II, 1 Clover, 4 single crystal HPGe detectors.

SHELS @ U400

*GABRIELA-III, 5 Clover HPGe detectors,
thick tunnel detectors for detecting CE.*

GRAND @ DC280.

2. Full scale experiments aimed to spectroscopy studies of $^{286,287}\text{Fl}$, ^{288}Mc and daughter nuclei.

*GABRIELA-III, 5 Clover HPGe detectors,
thick tunnel detectors for detecting CE.*

GRAND @ DC280.

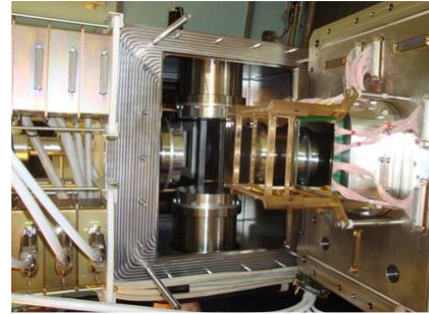

Spectroscopy of SHE at GRAND

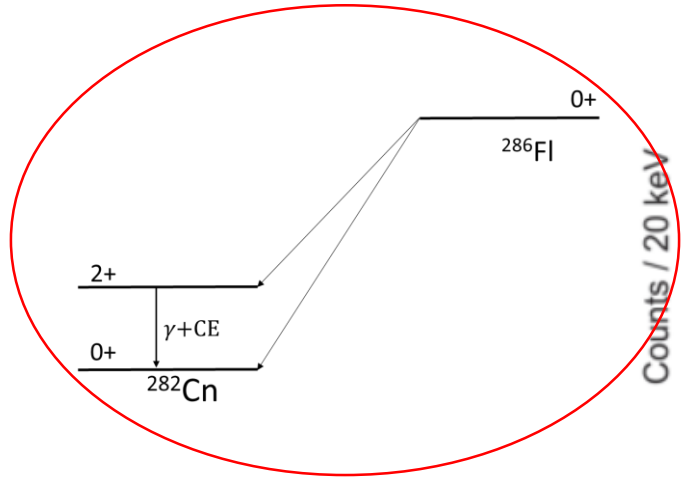

$^{242}\text{Pu} + ^{48}\text{Ca}$ reaction products (DGFRS2)

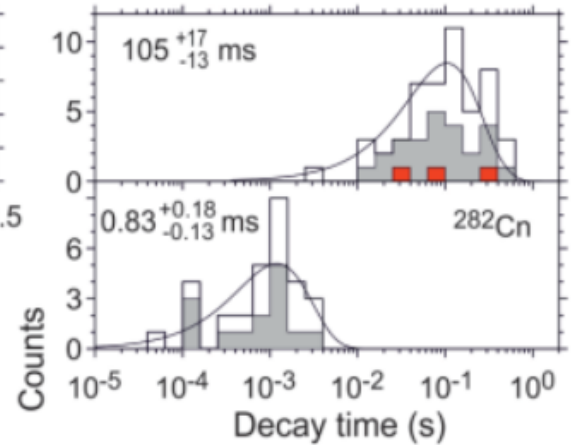
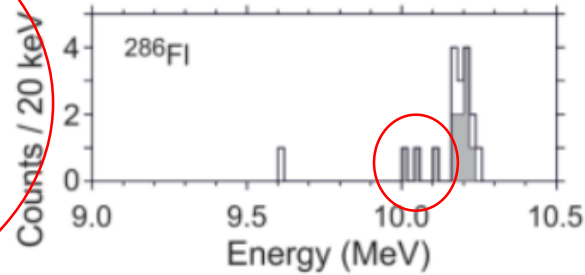

The several hundred α -decays of this nucleus that can be recorded during a 60-day experiment could provide data on the lowest levels ($0+$, $2+$) of the ground state transition of the nucleus ^{282}Ds . These data directly indicate the degree of deformation of the studied nucleus, i.e., the distance of the nucleus from the hypothetical region of spherical superheavy nuclei ("Island of Stability").

Yu. Ts. Oganessian et. al,
PHYSICAL REVIEW C **106**, 024612 (2022)

Spectroscopy of SHE at GRAND



target D = 480 mm

cross section $^{286}\text{Fl} \sim 5$ pbarn

$^{48}\text{Ca} \sim 3 \times 10^{13}$ pps. (5-6 μA)

$\epsilon_{\text{transmission}} \sim 40\%$

$\rightarrow 4 - 6$ ^{286}Fl / day

Yu. Ts. Oganessian et. al,
PHYSICAL REVIEW C **106**, 024612 (2022)

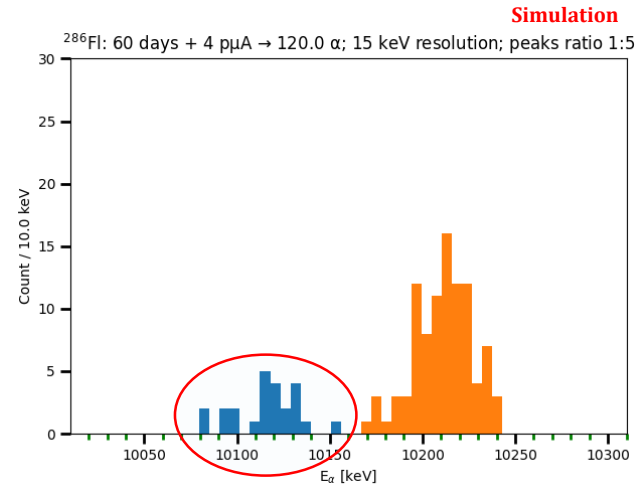
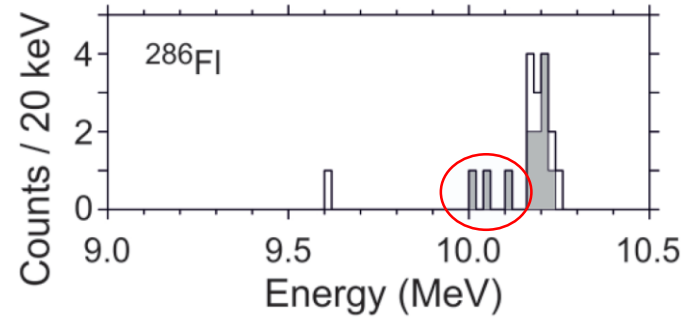

Separator GRAND Gas-filled Recoil Analyzer and Nuclei Detector

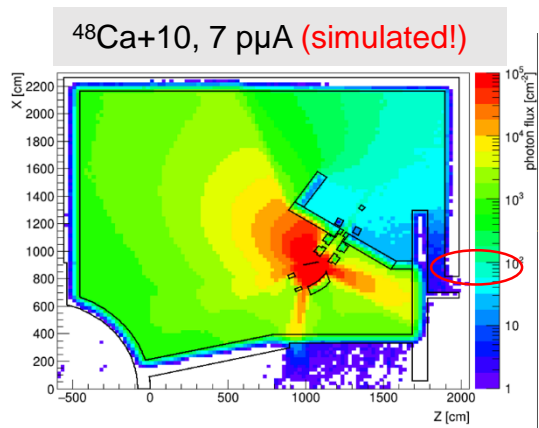

photon flux $< 50 \text{ cm}^{-2}$
measured

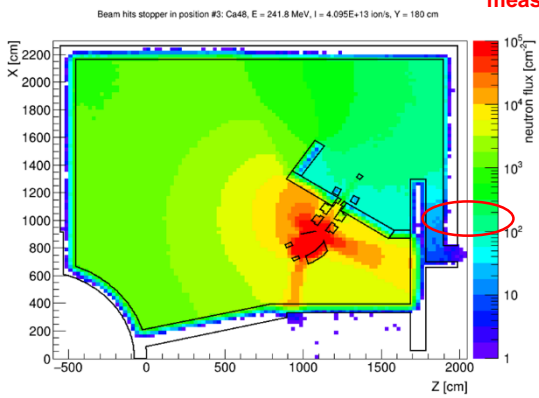

neutron flux $> 200 \text{ cm}^{-2}$
Measured for thermal neutrons

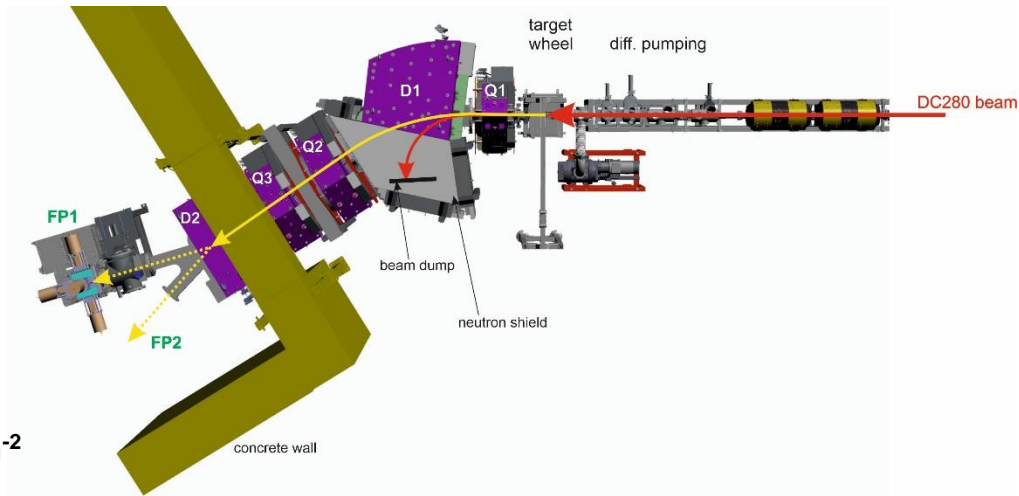

Separator **GRAND**
Gas-filled **R**ecoil **A**nalyzer and **N**uclei **D**etector

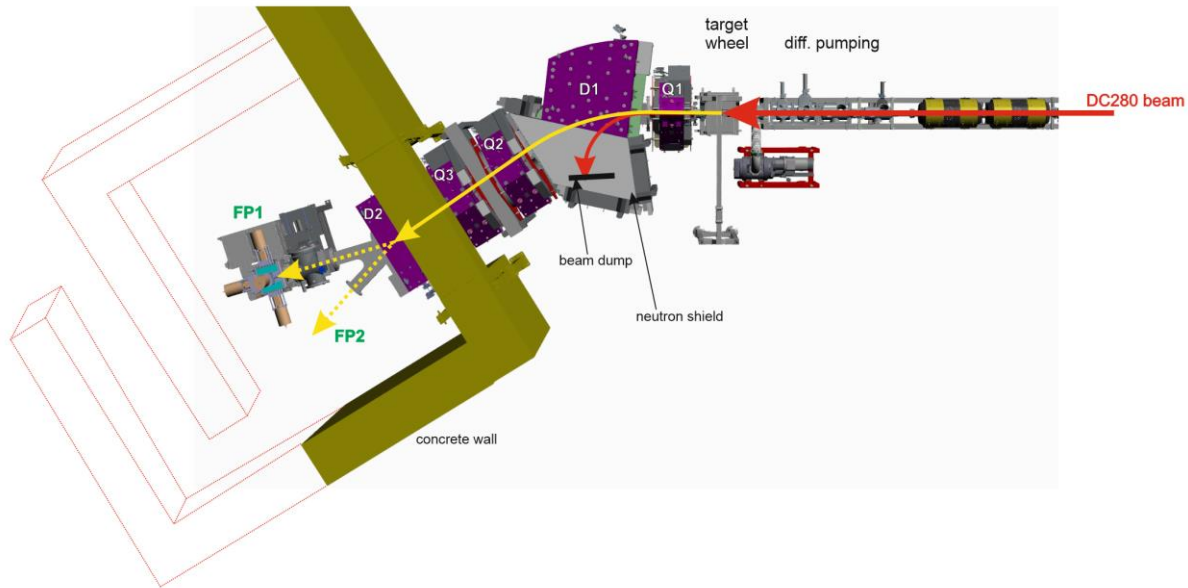

The detector cave
is planned to be built in 2025-2026

Spectroscopy of SHE at GRAND

Reaction $^{243}\text{Am}(^{48}\text{Ca}, 2-5n)^{286-289}\text{Mc}$ (DGFRS2)

67 decay chains

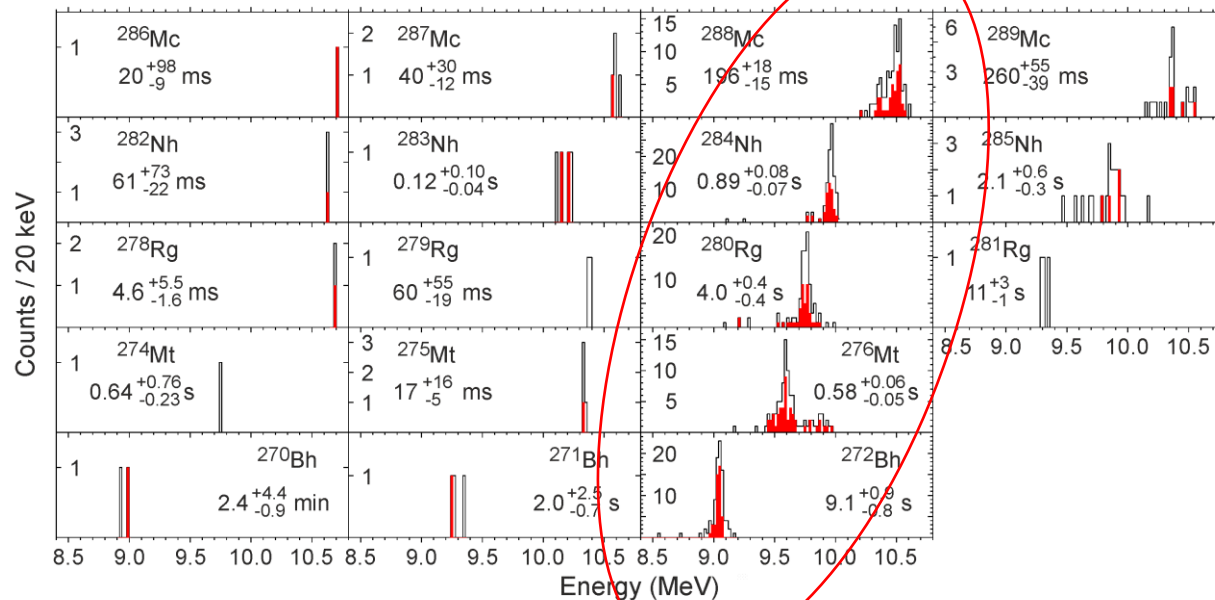

Spectroscopy of SHE at GRAND

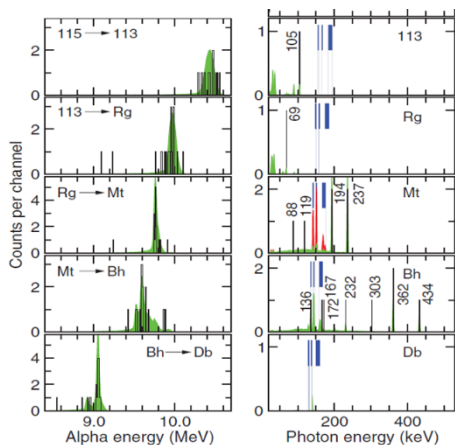

D. Rudolph *et. al.*, PRL 111, 112502 (2013)
TASCA + TASISpec
22 decay chains - 16 γ -quanta!

$^{243}\text{Am} + ^{48}\text{Ca}$

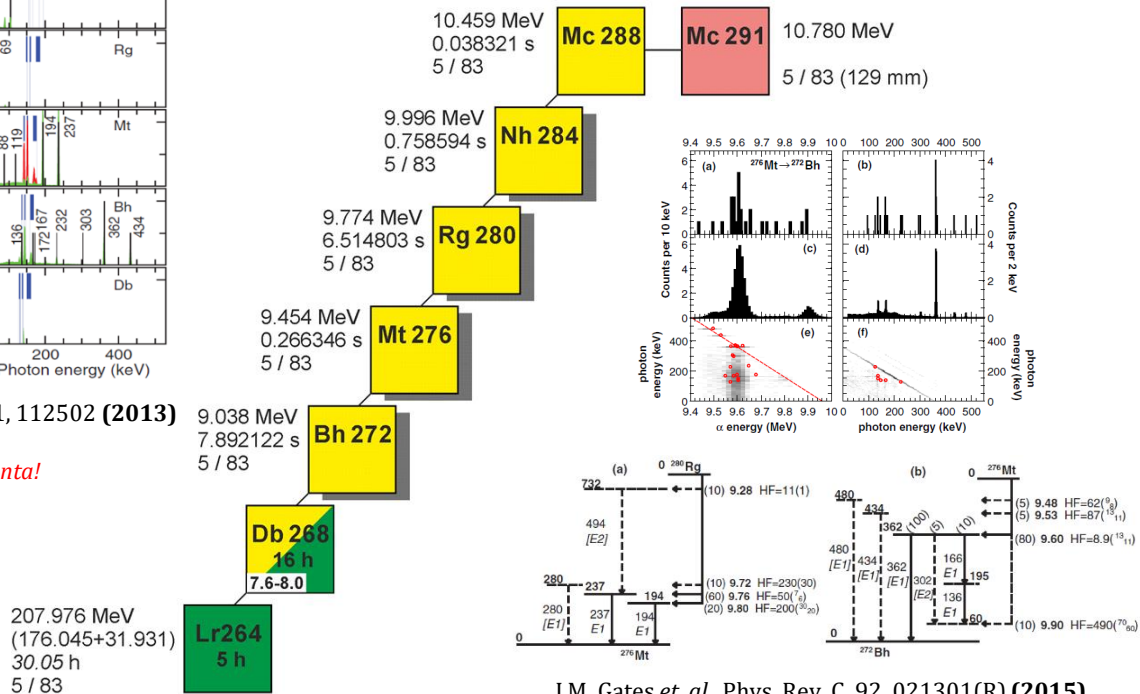

J.M. Gates *et. al.*, Phys. Rev. C. 92, 021301(R) (2015)
BGS + C3

55 new decay chains
(+31 in 2003, 2010-2012)
 SHE Factory, DGFRS II (2021)

Spectroscopy of SHE at GRAND



target D = 480 mm

cross section $^{288}\text{Mc} \sim 8$ pbarn

$^{48}\text{Ca} \sim 3 \times 10^{13}$ pps. (5-6 pμA)

$\epsilon_{\text{transmission}} \sim 40\%$

→ **6 - 8 ^{288}Mc / day**

100 days → 10^{20} ^{48}Ca ions → **600 - 800 ^{288}Mc**

The work can only be carried out once the “SHE Factory” has been upgraded to a Class-I RC-laboratory.

Spontaneous fission properties of SHE

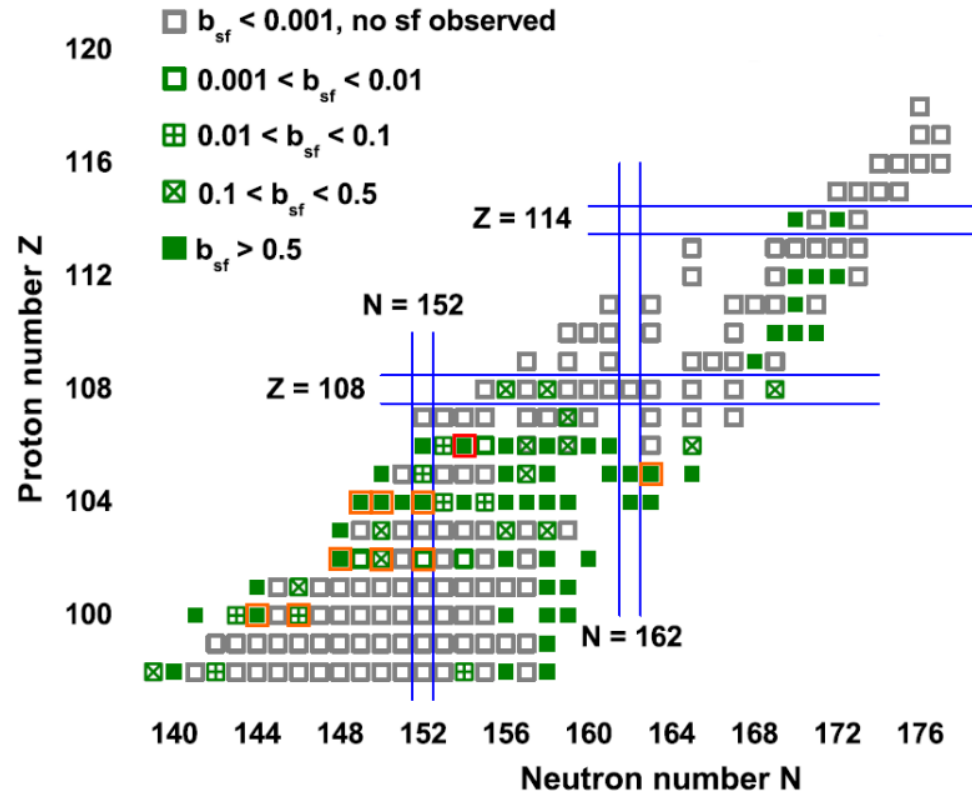

the isotopes for which spontaneous fission branches have been reported so far.
F.P. Hesberger - Eur. Phys. J. A (2017)53, 75

The orange and red boxes – SF nuclei which have been studied on the VASSILISA (SHELS) separator

Spontaneous fission properties of SHE

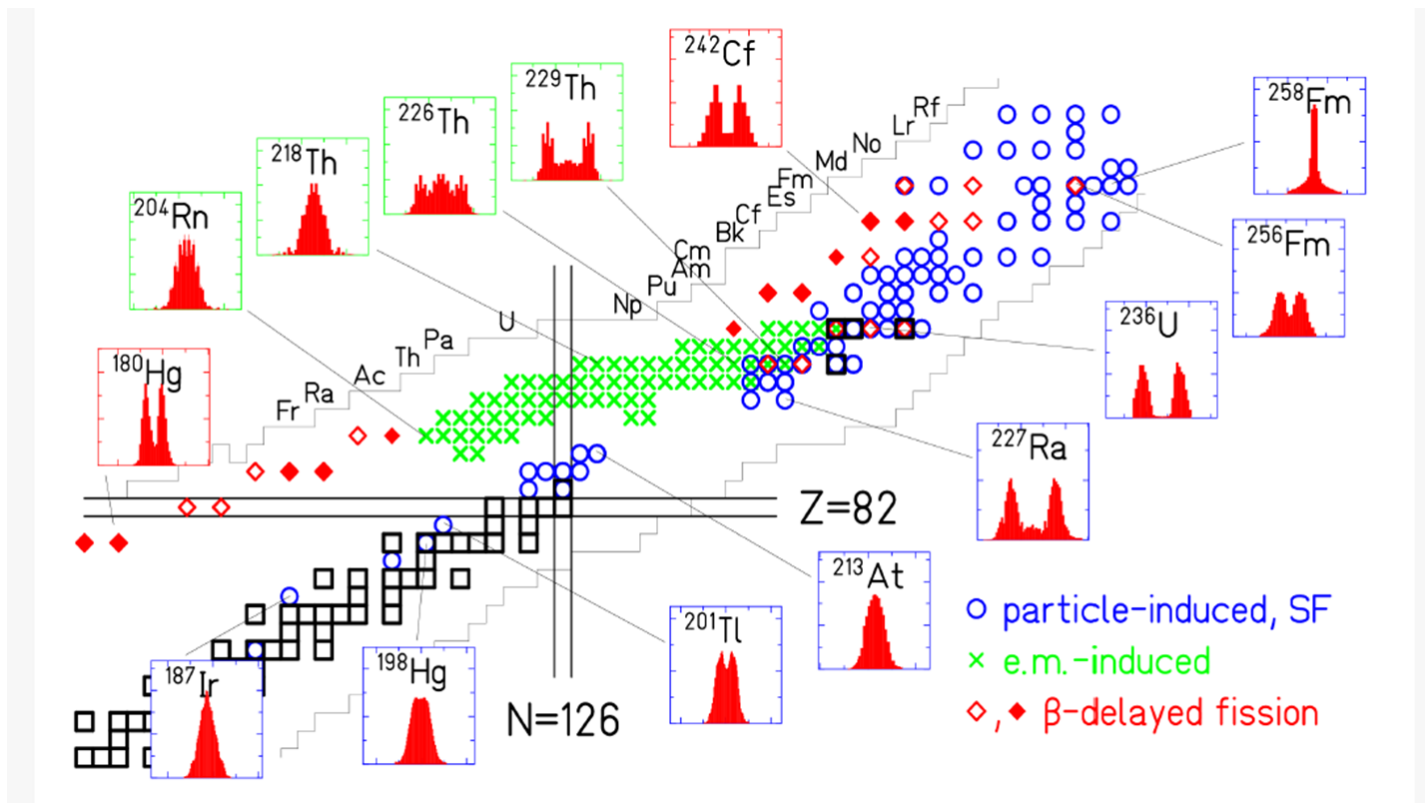

General view on the systems for which mass or nuclear-charge distributions have been measured.

K.H. Schmidt, B. Jurado, Rev. Prog. Nucl. Fiss (2018)

Spontaneous fission properties of SHE

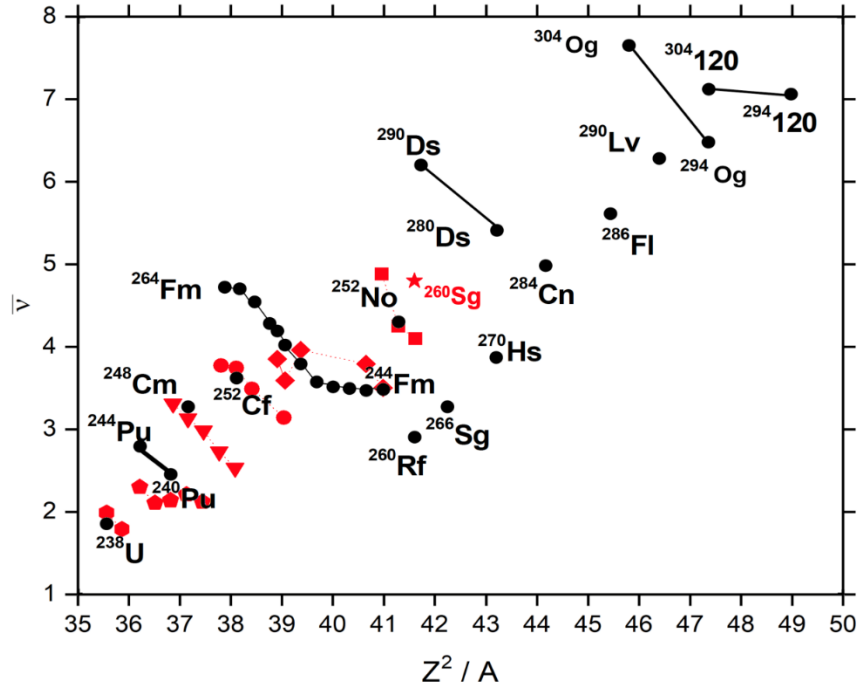

Rubchenya, V.A. Prompt neutron characteristics
in the spontaneous fission of heavy and superheavy nuclei.
LXV International Conference "Nucleus 2015" June 29-July 3, 2015, St. Petersburg

Spontaneous fission properties of SHE



SHELS separator (FLNR)

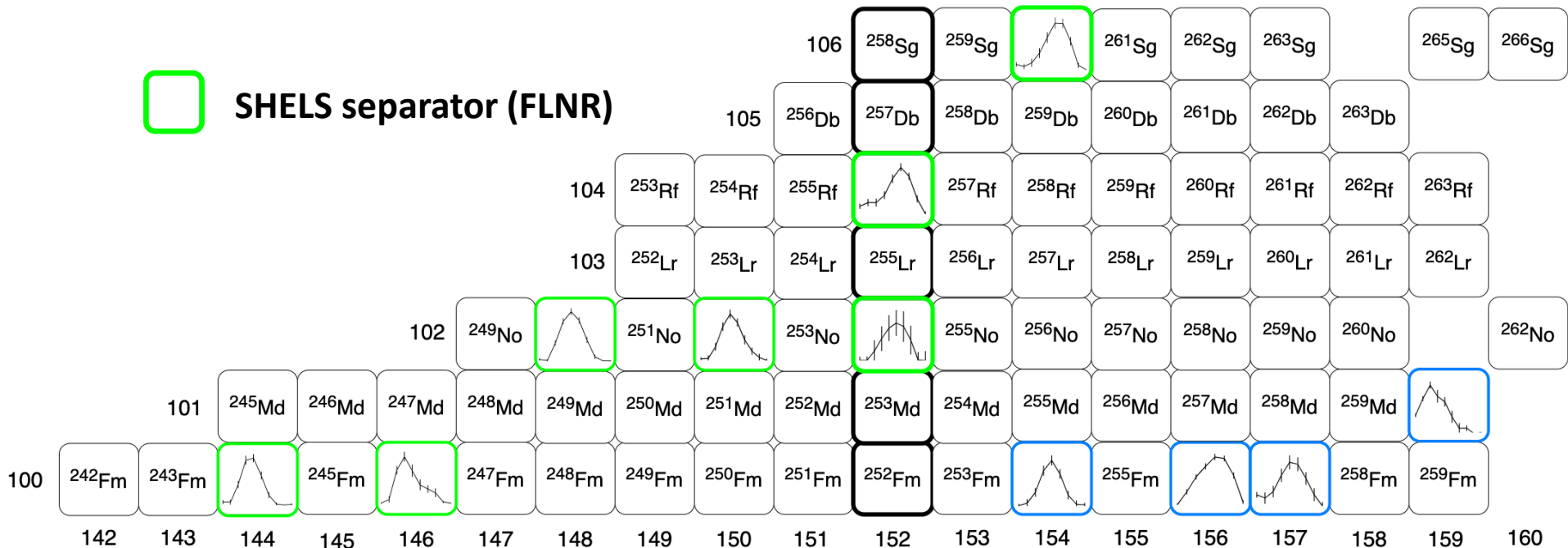

Spontaneous fission properties of SHE

SFiNx Spontaneous Fission, Neutrons and x-rays

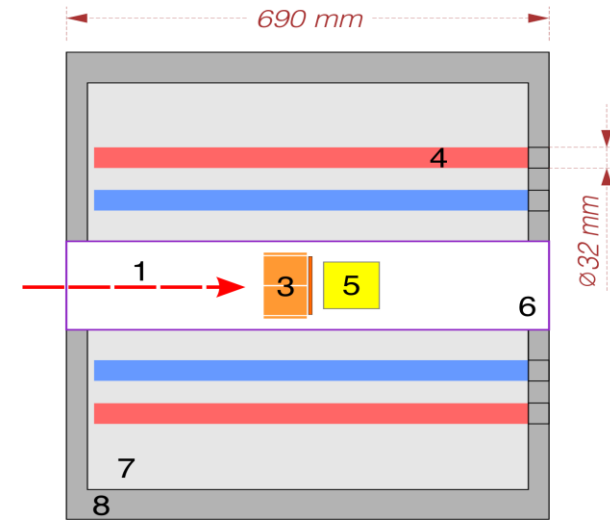
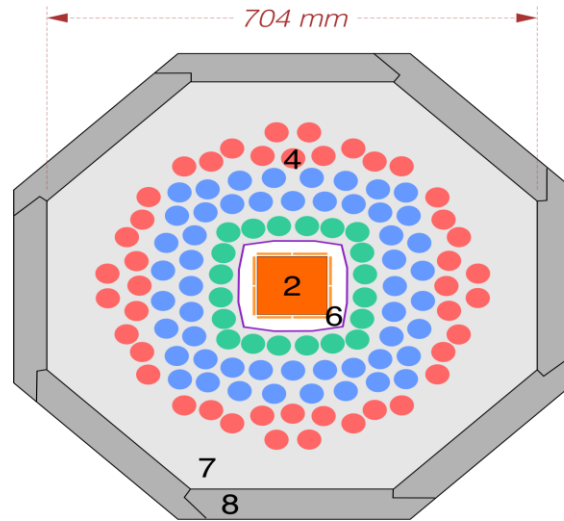

Isaev, A. V. et al.
The SFiNx detector system
PEPAN Letters 19, 37–45 (2022)

Isaev, A. V. et al.
Study of spontaneous fission using
the SFiNx system
APP B Proc. Suppl. 14, 835–839 (2021)

- 1 – ER “beam”
- 2,3 – DSSSD box
- 4 - ^3He -based N counters
- 5 – scintillator
- 6 – vacuum chamber
- 7 – neutron moderator
- 8 – neutron shield

$$\epsilon_n = 55\%$$

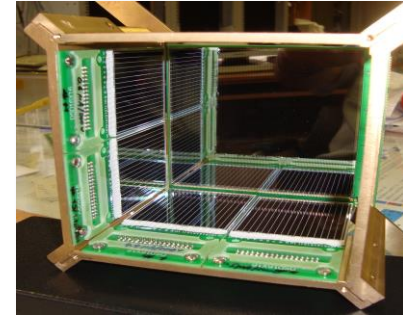

DSSD 100×100 MM
128×128 strips

Spontaneous fission properties of SHE

The estimation of half life	>	5 decays
The average number of SF neutrons ($\epsilon_n > 45\%$)	>	10 fissions
The determination of neutron multiplicity distribution ($\epsilon_n > 45\%$)	>	100 fissions
The evaluation of TKE (2 FF!)	>	100 fissions
The determination of energy or mass distribution of single fission fragments	>	10^5 fissions

Spontaneous fission properties of SHE

To create the correct mass distribution of fission fragments we need to register $\geq 10^5$ fission fragments !!!

	^{254}No	^{252}No (April 2024)
Cross section of ER formation	2000 nb	186 nb
Branching ratio	$b_\alpha = 90\%$ ($b_{sf} = 0.17\%$)	$b_{SF} = 33\%$
Efficiency of detection	$\epsilon_\alpha = 50\%$	$\epsilon_{SF} = 100\%$
I beam = 1 μA of ^{48}Ca	120 000 alphas from ^{254}No per 24h	25 000 fissions of ^{252}No per 24h
I beam = 6 μA of ^{48}Ca	720 000 alphas from ^{254}No per 24h <i>2500 fissions from ^{254}No per 24h</i>	100 000 fissions of ^{252}No per 24h

The implantation “box” detector

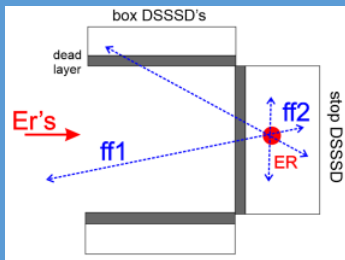

$\epsilon_{\text{det}} = 100 \%$
100 000 F1 or F2 events per 24h

F1 and F2 $\epsilon_{\text{det}} = 50 \%$
50 000 F1+F2 events per 24h

2E method (+ neutrons)
TKE + neutrons!
**Mass measurements
not supported**

Recoil separator + CORSET-like detector

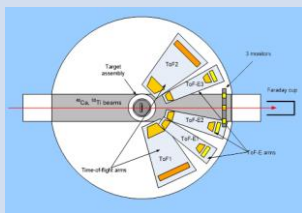

$\epsilon_{\text{det}} = 0.2 \%$

200 SF events
per 24h

2V, TOF-E methods
TKE, fr. masses
 $2 < \Delta M < 4$ amu

ANSWERS-like setup

$^{48}\text{Ca} + ^{207}\text{Pb}$ @ **TASCA**

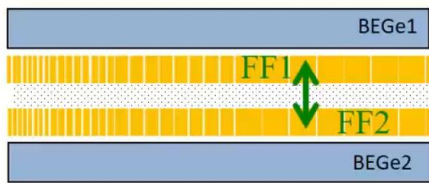

$\epsilon_{\text{det}} = 80-90 \%$
 $\epsilon_{\text{tr}} \approx 50\%$ (for nobelium!)

40 000 – 50 000 SF events
per 24h

2E methods
TKE, fr. masses, neutrons

$5 < \Delta M < 10$ amu

Spontaneous fission properties of SHE

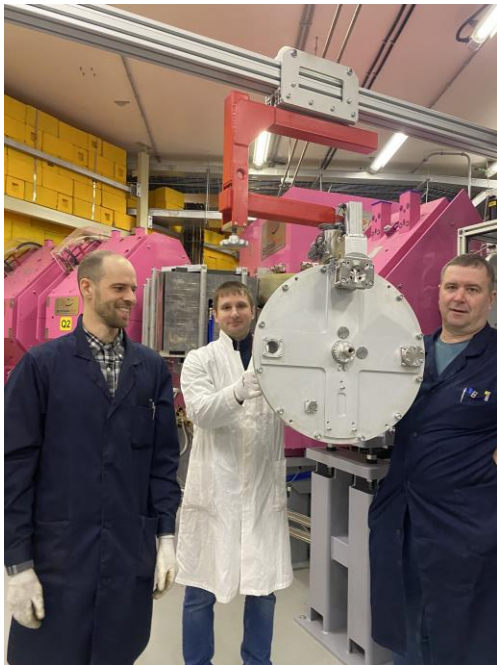

First tests of new rotating target
 $D = 480$ mm and $6 \mu\text{A}$ of ^{48}Ca
 SHE Factory, April 2024

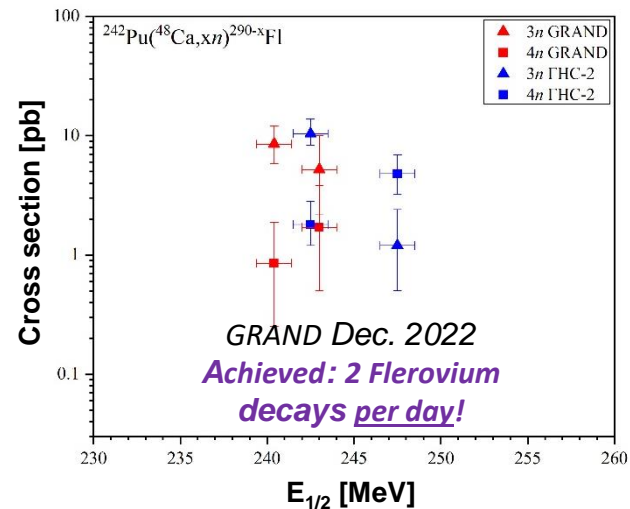
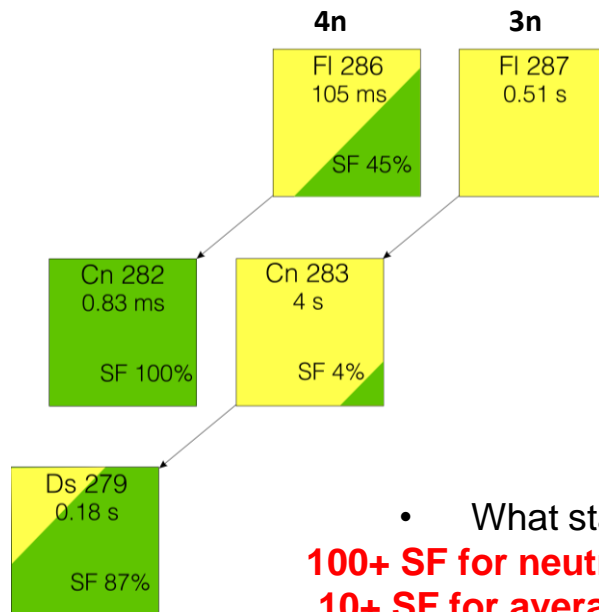

- What statistics are needed?
100+ SF for neutron multiplicity and TKE
10+ SF for average number of neutrons
4-5 SHE-isotopes in the one experiment!!!

CONCLUSION

Reaction	Nuclei	Number of nuclei in the focal plane of the separator	Properties of nuclei available for study
$^{48}\text{Ca} + ^{204-208}\text{Pb}$	$^{249-254}\text{No}$	$\leq 2.5 \times 10^5 / 24\text{h}$	α -, β -, γ -spectroscopy, fission fragment spectroscopy (TKE, ff-masses, neutron multiplicity)
$^{48}\text{Ca} + ^{242}\text{Pu}$	$^{286,287}\text{Fl}$ $^{282,283}\text{Cn}...$	$\leq 10 / 24\text{h}$	Transactinide chemistry, decay modes, α -, β -, γ -spectroscopy, spontaneous fission characteristics (TKE, neutron multiplicity)
$^{48}\text{Ca} + ^{243}\text{Am}$	^{288}Mc Nh,Rg,Mt...	$\leq 10 / 24\text{h}$ (RCL - I)	Transactinide chemistry, decay modes, α -, β -, γ -spectroscopy, spontaneous fission characteristics (TKE, neutron multiplicity)



Thank you
for your attention!

